

MANUAL TRANSMISSION

MODEL R4M21, R5M21 and V5M21

CONTENTS

GENERAL INFORMATION	22A-0-3
1. SPECIFICATIONS	22A-1-1
TRANSMISSION MODEL TABLE	22A-1-1
GENERAL SPECIFICATIONS	22A-1-9
SERVICE SPECIFICATIONS	22A-1-11
TORQUE SPECIFICATIONS	22A-1-12
SEALANTS, ADHESIVES AND GREASE	22A-1-14
ADJUSTMENT SNAP RINGS AND SPACERS	22A-1-15
2. SPECIAL TOOLS	22A-2-1
3. TRANSMISSION	22A-3-1
4. CONTROL HOUSING	22A-4-1
5. CONTROL LEVER	22A-5-1
6. COUNTERSHAFT	22A-6-1
7. EXTENTION HOUSING	22A-7-1
8. MAINDRIVE GEAR	22A-8-1
9. MAINSHAFT	22A-9-1
10. SPEEDOMETER GEAR	22A-10-1
11. TRANSFER <EXCEPT V5M21-A>	22A-11-1
11a. TRANSFER <V5M21-A>	22A-11a-1
12. REAR OUTPUT SHAFT <EXCEPT V5M21-A>	22A-12-1
12a. REAR OUTPUT SHAFT <V5M21-A>	22A-12a-1
13. INPUT SHAFT <EXCEPT V5M21-A>	22A-13-1
13a. INPUT SHAFT <V5M21-A>	22A-13a-1
14. FRONT OUTPUT SHAFT	22A-14-1
15. H-L SHIFT FORK	22A-15-1
16. 2WD/4WD SHIFT FORK AND RAIL <V5M21-A>	22A-16-1
17. 2WD/4WD SYNCHRONIZER <V5M21-A>	22A-17-1
18. TRANSFER CASE PLATE <V5M21-A>	22A-18-1

GENERAL INFORMATION

KM130-6
R4M21-1-B

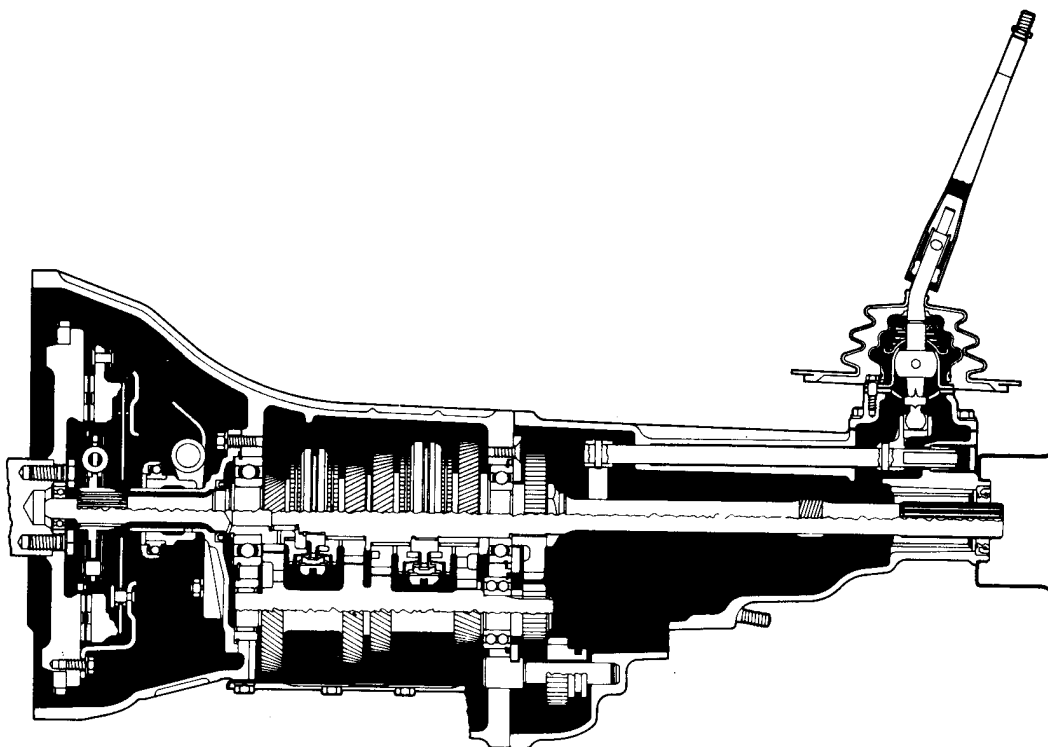

130009

KM131-3
R4M21-2-B

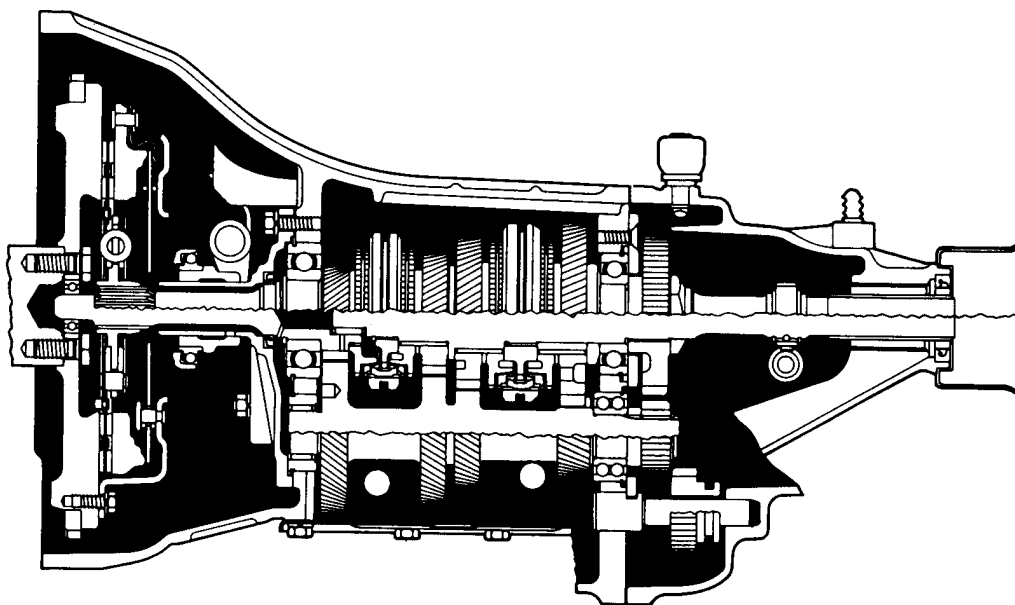

1310011

KM132-B, G, H, I
R5M21-2-D, J

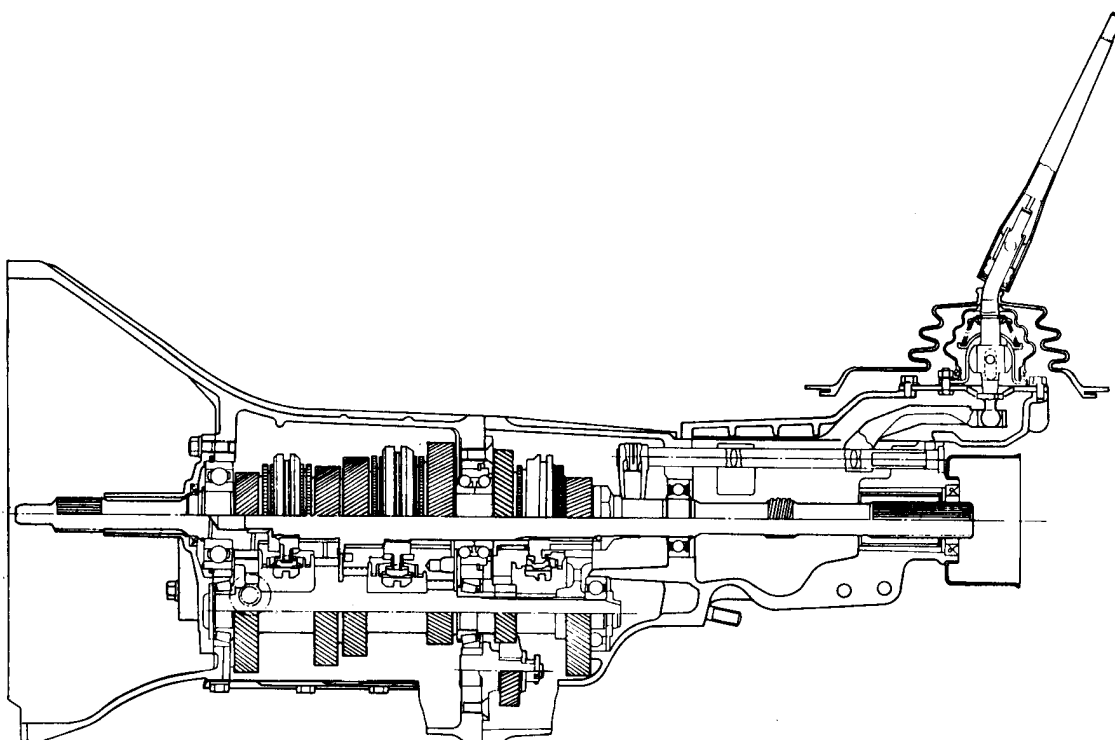

132063

KM132-M, N
R5M21-4-K

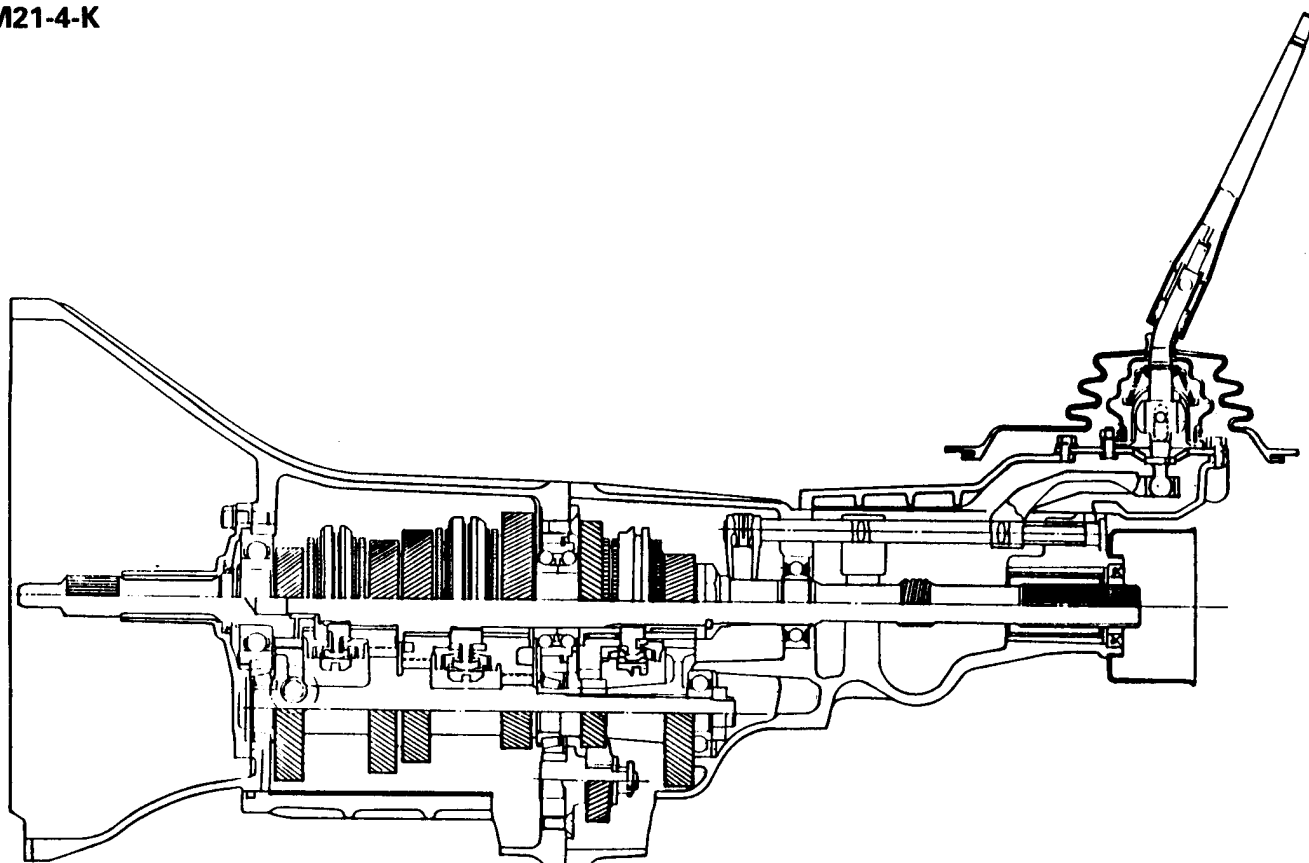

1320002

The KM132-M, KM132-N and R5M21-4-K models are new additions to the KM130 series, and are modified versions of the KM132-G models. Their major differences from the KM132-G models are shown below.

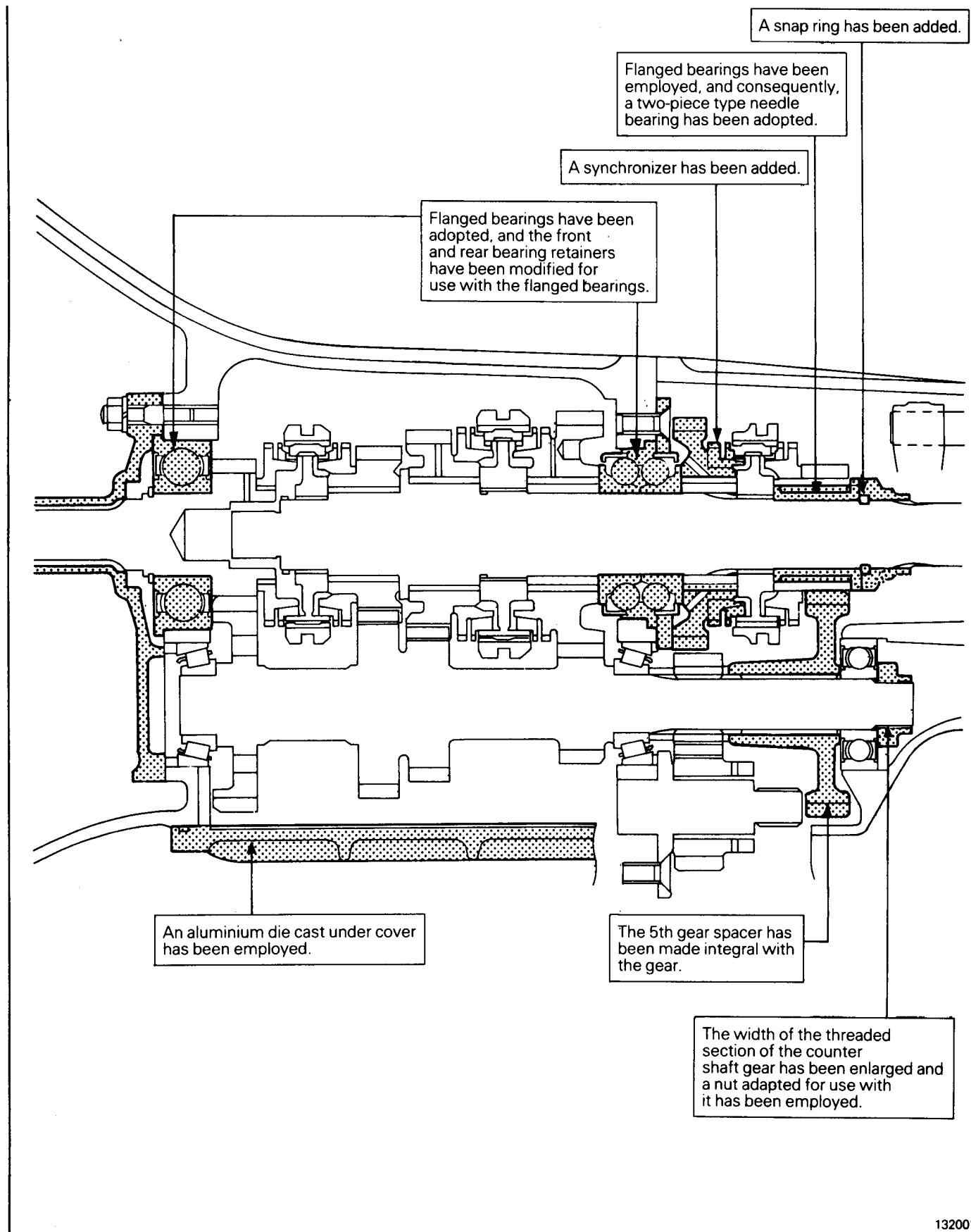

KM135-1, 9
R5M21-2-C, E

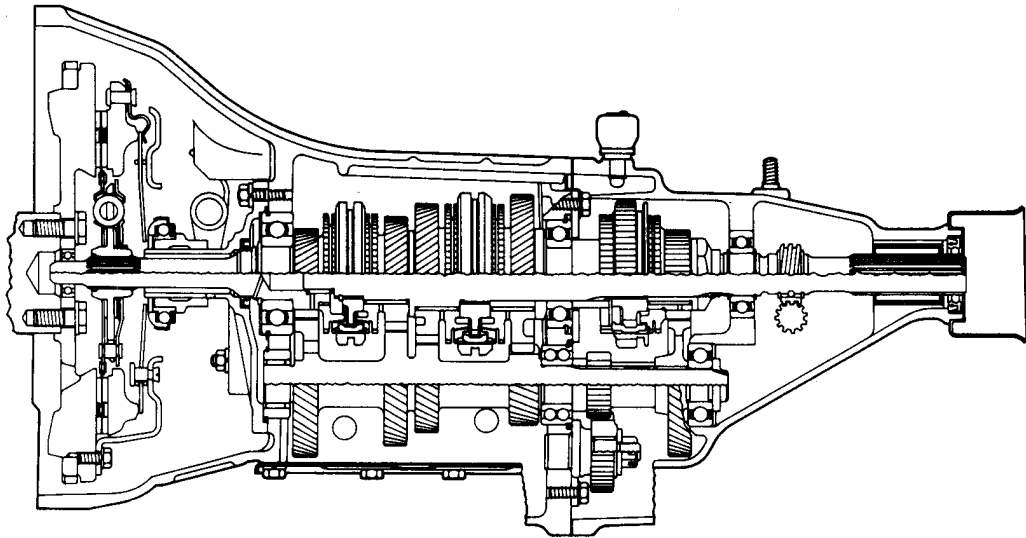

135001

KM145-6
V5M21-1-D

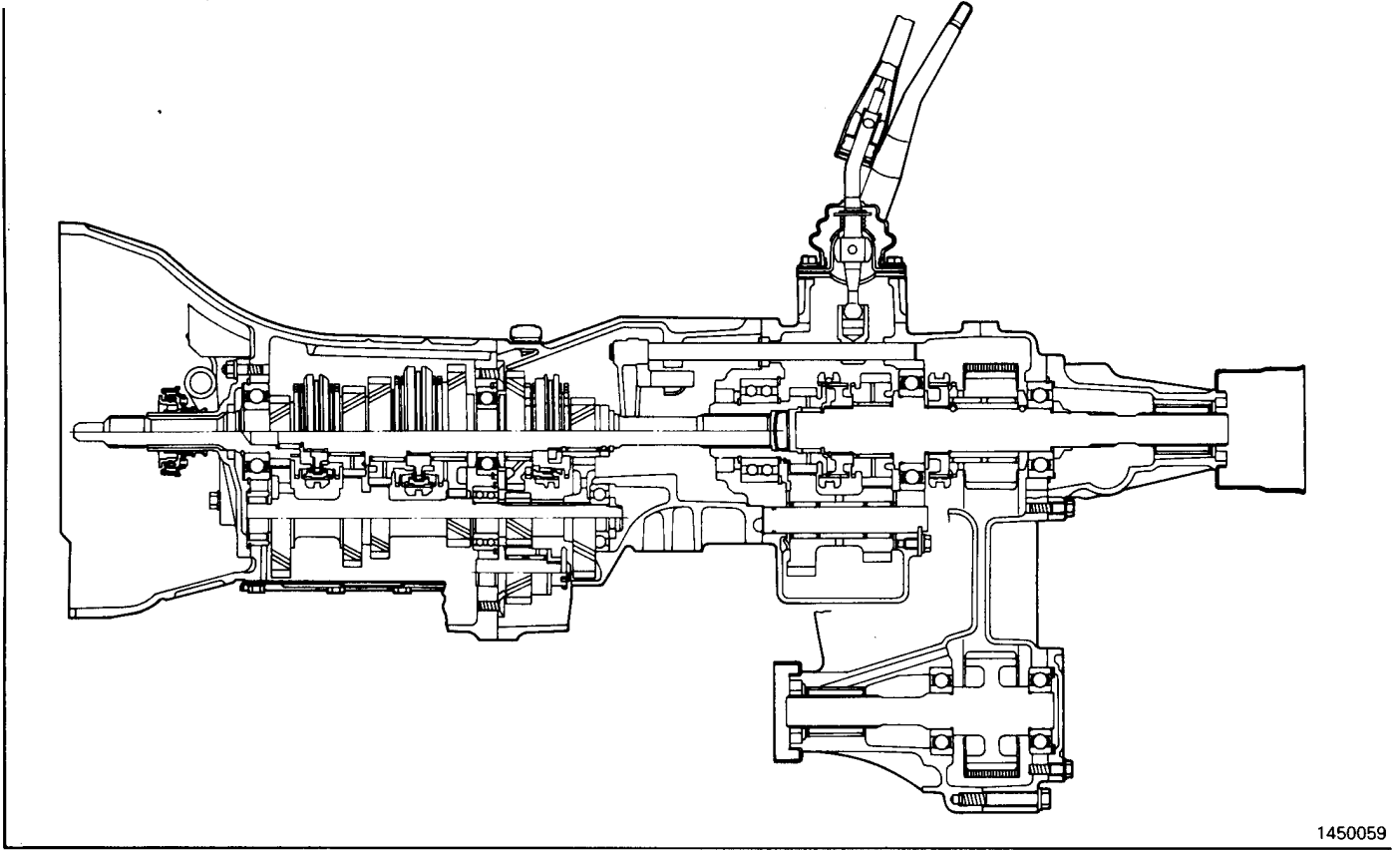

1450059

KM145-8
V5M21-1-J

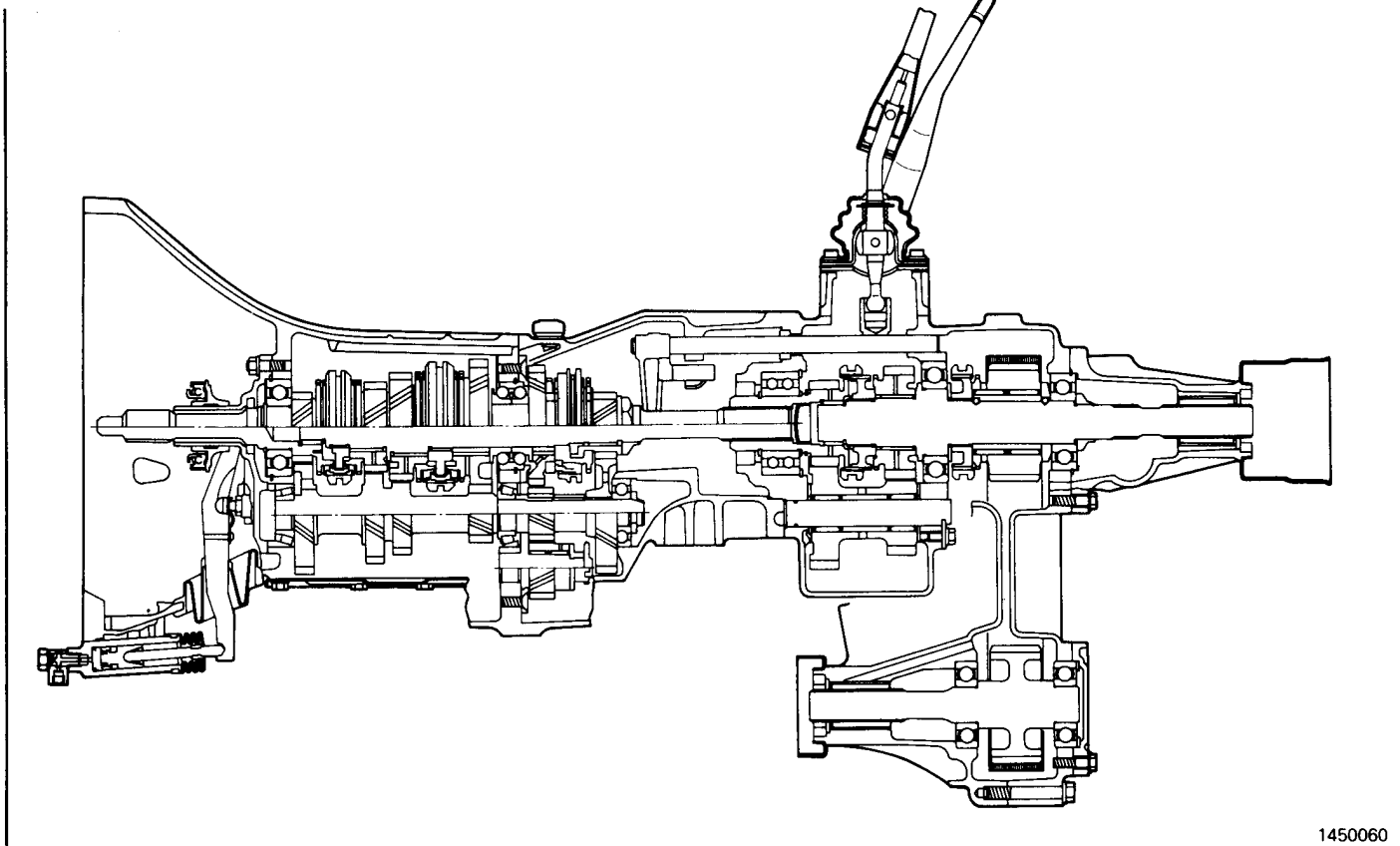

1450060

KM147-3
V5M21-2-E

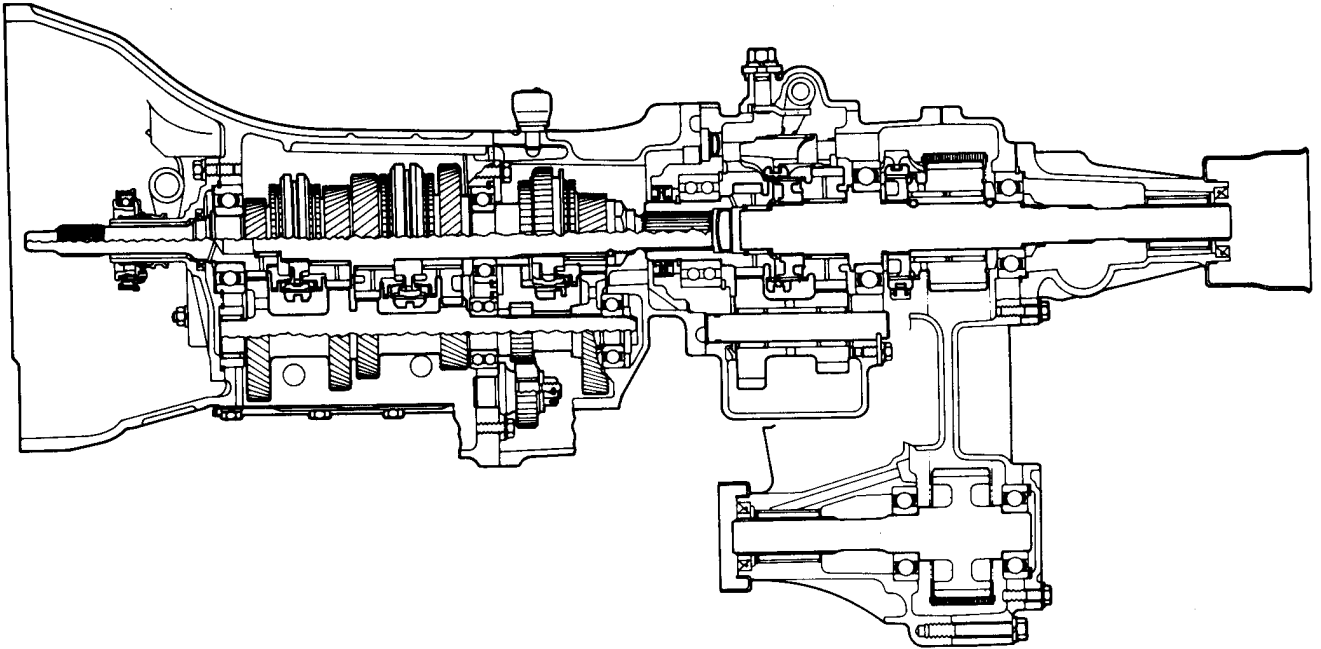

147006

KM147-5
V5M21-2-G
V5M21-4-Q

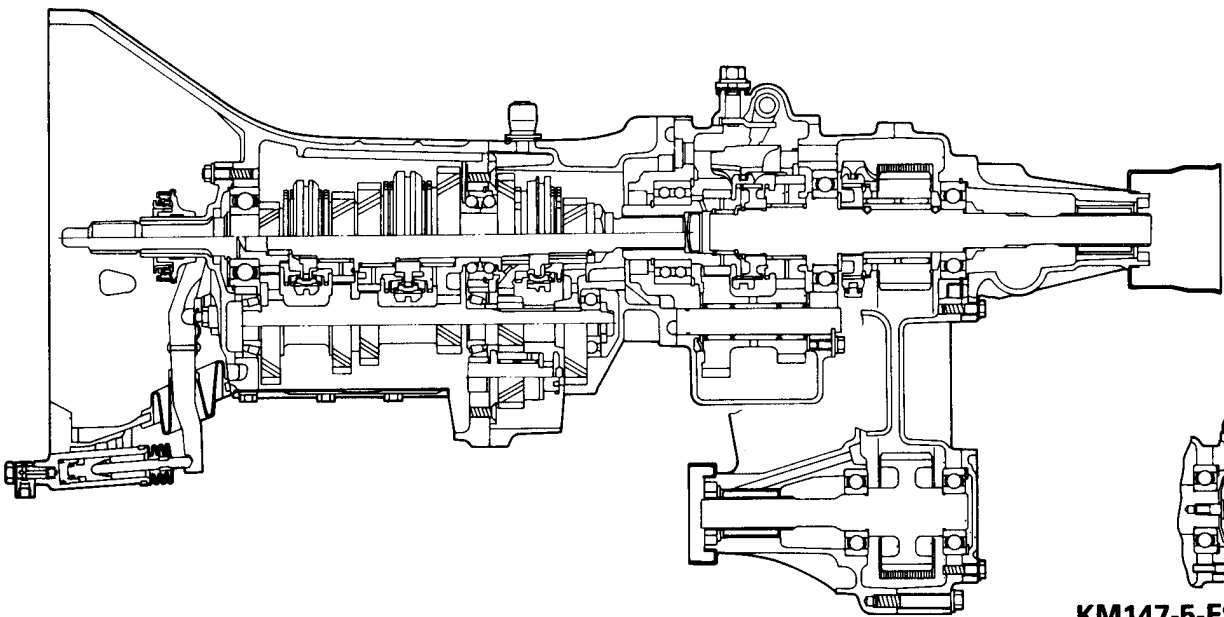

KM147-5-FS
KM147-5-MS
V5M21-2-GFS
V5M21-4-QFSL
V5M21-4-QGS

1470022

V5M21-5

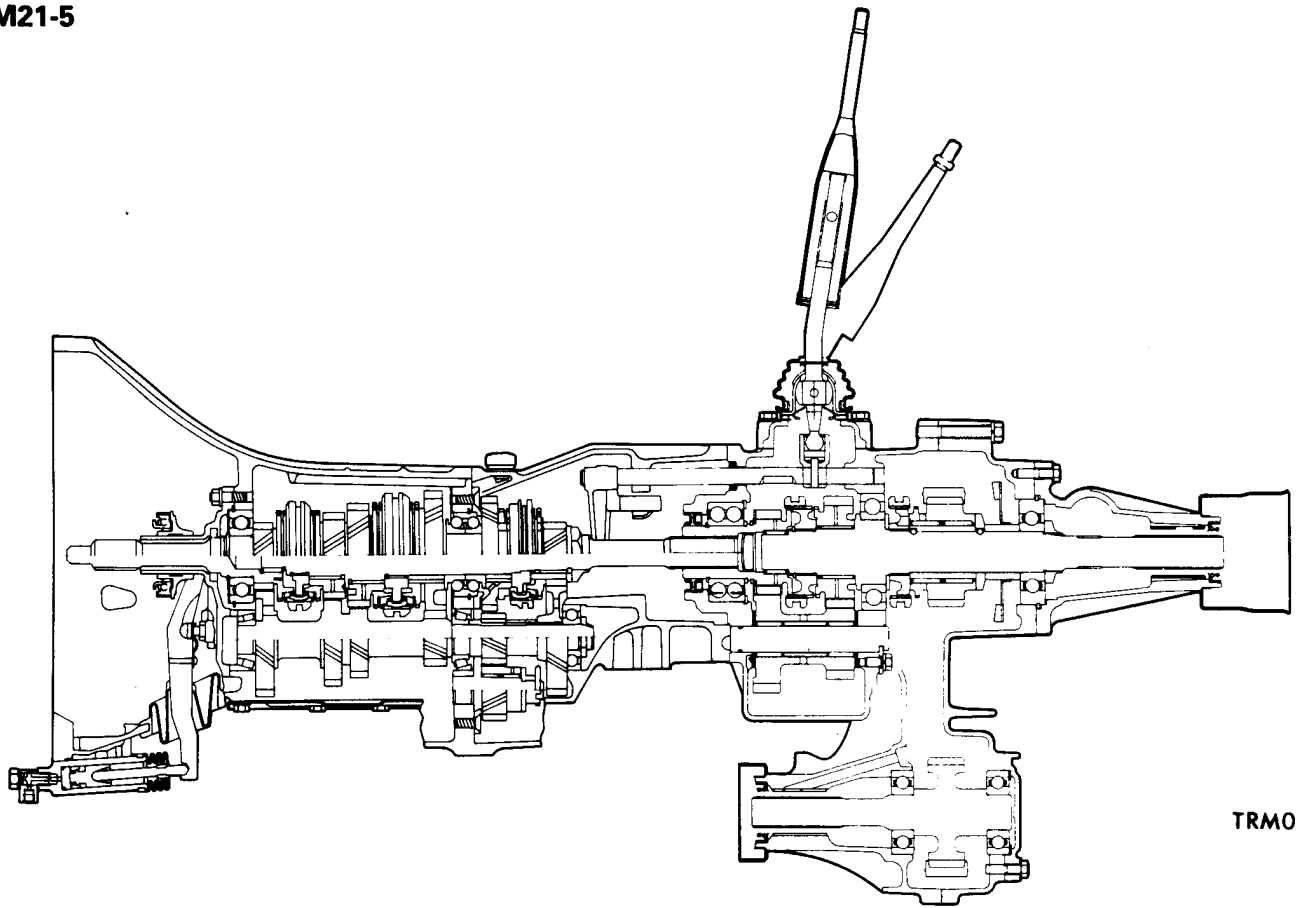

TRM0241

Intentionally blank

KM145, V5M21-1, 4 – Major Differences

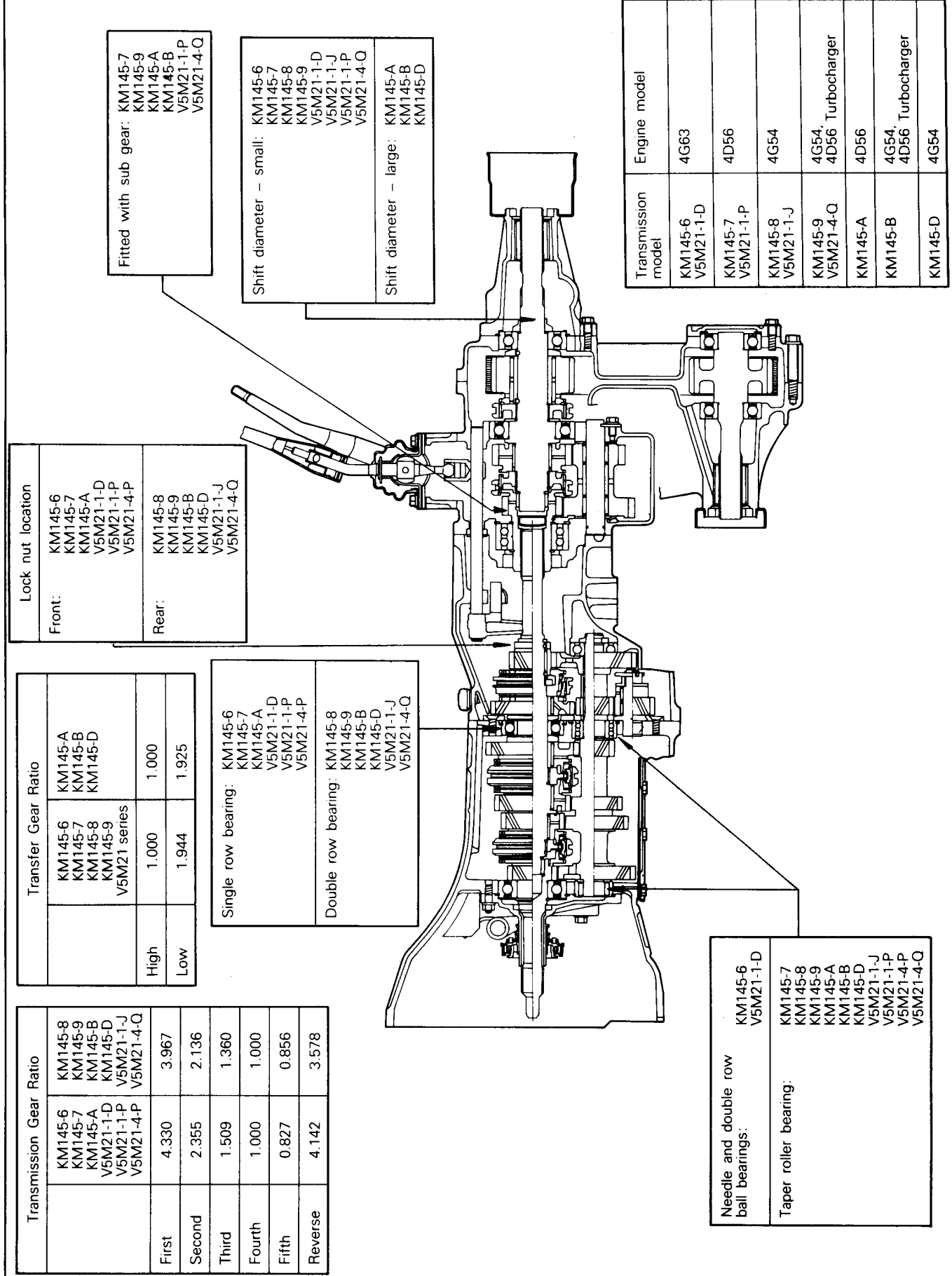

Fitted with sub gear: KM145-7
KM145-9
KM145-A
KM145-B
V5M21-1-P
V5M21-4-Q

Shift diameter – small: KM145-6
KM145-7
KM145-8
KM145-9
V5M21-1-D
V5M21-1-J
V5M21-1-P
V5M21-4-Q

Shift diameter – large: KM145-A
KM145-B
KM145-D

Transmission model	Engine model
KM145-6 V5M21-1-D	4G63
KM145-7 V5M21-1-P	4D56
KM145-8 V5M21-1-J	4G54
KM145-9 V5M21-4-Q	4G54, 4D56 Turbocharger
KM145-A	4D56
KM145-B	4G54, 4D56 Turbocharger
KM145-D	4G54

Lock nut location	
Front:	KM145-6 KM145-7 KM145-A V5M21-1-D V5M21-1-P V5M21-4-P
Rear:	KM145-8 KM145-9 KM145-B KM145-D V5M21-1-J V5M21-4-Q

Transfer Gear Ratio	
High	1.000
Low	1.925

Single row bearing: KM145-6
KM145-7
KM145-A
V5M21-1-D
V5M21-1-P
V5M21-4-P

Double row bearing: KM145-8
KM145-9
KM145-B
KM145-D
V5M21-1-J
V5M21-4-Q

Transmission Gear Ratio	
First	4.330
Second	2.355
Third	1.509
Fourth	1.000
Fifth	0.827
Reverse	4.142

Needle and double row ball bearings: KM145-6
V5M21-1-D

Taper roller bearing: KM145-7
KM145-8
KM145-9
KM145-A
KM145-B
KM145-D
V5M21-1-J
V5M21-1-P
V5M21-4-P
V5M21-4-Q

KM147, V5M21-2 – Major Differences

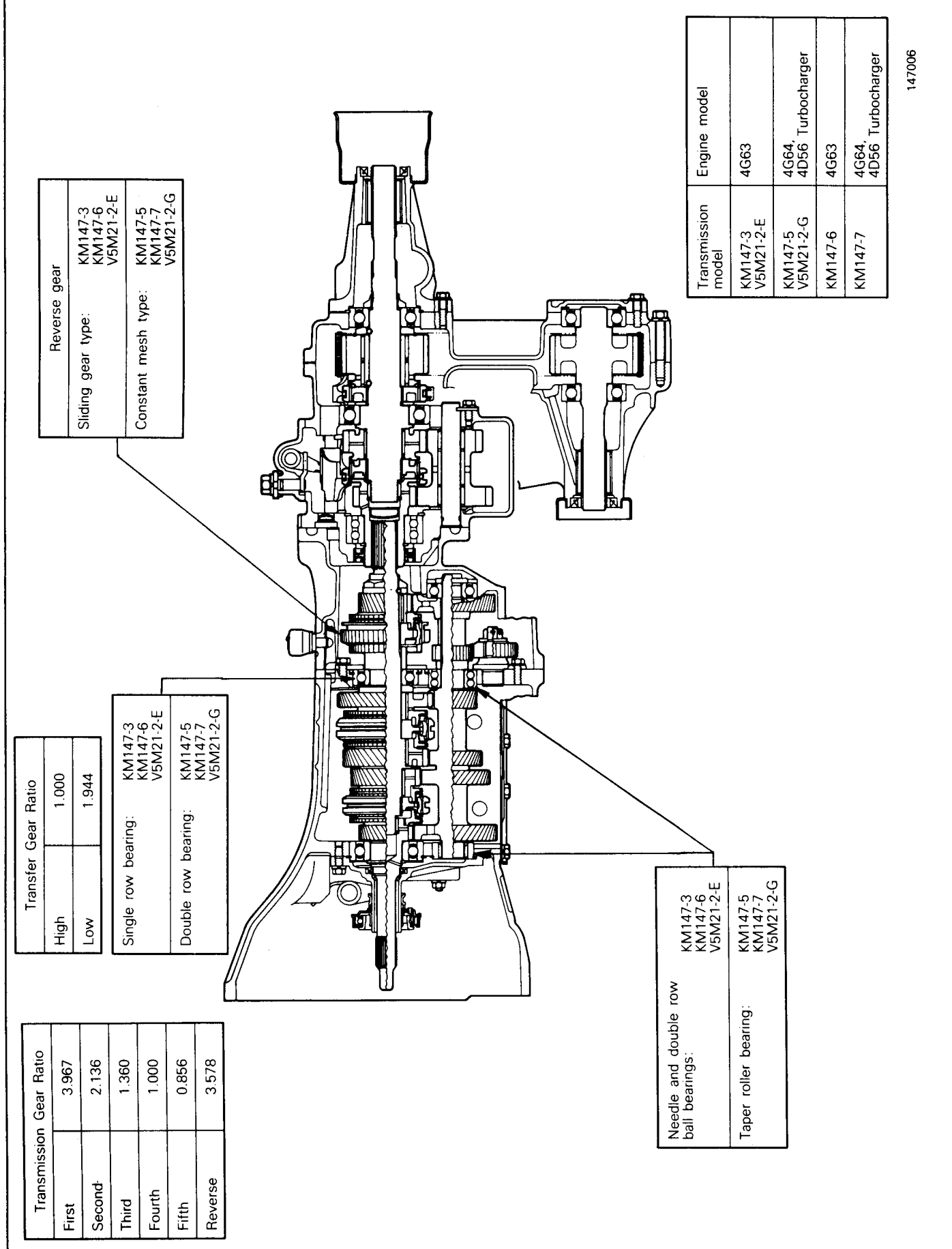

Transfer Gear Ratio	
High	1.000
Low	1.944

Single row bearing:	KM147-3 KM147-6 V5M21-2-E
Double row bearing:	KM147-5 KM147-7 V5M21-2-G

Reverse gear	KM147-3 KM147-6 V5M21-2-E
Sliding gear type:	KM147-5 KM147-7 V5M21-2-G
Constant mesh type:	

Transmission Gear Ratio	
First	3.967
Second	2.136
Third	1.360
Fourth	1.000
Fifth	0.856
Reverse	3.578

Needle and double row ball bearings:	KM147-3 KM147-6 V5M21-2-E
Taper roller bearing:	KM147-5 KM147-7 V5M21-2-G

Transmission model	Engine model
KM147-3 V5M21-2-E	4G63
KM147-5 V5M21-2-G	4G64, 4D56 Turbocharger
KM147-6	4G63
KM147-7	4G64, 4D56 Turbocharger

1. SPECIFICATIONS

TRANSMISSION MODEL TABLE – MODEL 1987

Transmission Model	Gear ratio	Speedometer gear ratio	Vehicle Model	Engine Model
EC KM132-G-B	E	22/8	STARION	4G63 intercooler turbocharger
KM132-G-BL	E	22/8	STARION	4G63 intercooler turbocharger
KM132-G-BNL	E	22/8	STARION	G54B intercooler turbocharger
KM132-H-I	D	29/8	L200-2WD	4G63
KM132-H-IL	D	29/8	L200-2WD	4G63
KM132-J-G	D	27/8	L200-2WD	4D56
KM132-J-GL	D	27/8	L200-2WD	4D56
KM132-L-JL	D	30/8	L200-2WD	4G32
KM135-1-T	F	17/5	L300-2WD (TRUCK)	G32B
KM135-5-A	D	15/5	L300-2WD	4G32
KM135-8-G	D	21/5	L300-2WD	4D56
KM135-8-TF	D	17/5	L300-2WD (TRUCK)	4D56
KM135-9	C	18/5	L300-2WD	4G32
KM135-9-P	C	18/5	L300-2WD	G63B
KM135-9-T	C	18/5	L300-2WD (TRUCK)	4G32
KM135-B-GP	C	21/5	L300-2WD	4D56
KM145-6-TG	H	27/8	L200-4WD	4G63
KM145-6-TGL	H	22/8	L200-4WD	4G63
KM145-9-F	J	26/8	PAJERO/MONTERO	4D56 turbocharger
KM145-9-FL	J	26/8	PAJERO/MONTERO	4D56 turbocharger
KM145-9-G	J	27/8	PAJERO/MONTERO	4G54, 4D56 turbocharger
KM145-9-GL	J	27/8	PAJERO/MONTERO	4G54, 4D56 turbocharger
KM147-3-J	J	30/8	L300-4WD	4G63
KM147-5-F	J	26/8	L300-4WD	G64B

Transmission Model	Gear ratio	Speedometer gear ratio	Vehicle Model	Engine Model
EXP KM130-6-I	A	29/8	L200-2WD	4G32
KM130-6-IL	A	29/8	L200-2WD	4G32
KM130-6-J	A	30/8	L200-2WD	4G32
KM130-6-JL	A	30/8	L200-2WD	4G32
KM131-3	A	18/5	L300-2WD	4G32
KM131-3-F	A	25/5	L300-2WD	4G32
KM132-B-EU	E	25/8	STARION	4G63 turbocharger
KM132-B-EUL	E	25/8	STARION	4G63 turbocharger
KM132-H-H	D	28/8	L200-2WD	4G63
KM132-H-HL	D	28/8	L200-2WD	4G63
KM132-H-GL	D	27/8	L200-2WD	4G63
KM132-J-E	D	25/8	L200-2WD	4D56
KM132-J-EL	D	25/8	L200-2WD	4D56
KM135-5-F	D	20/5	L300-2WD	4G32
KM135-8-G	D	21/5	L300-2WD	4D56
KM135-9-EP	C	19/5	L300-2WD	4G63
KM135-B-GP	C	21/5	L300-2WD	4D56
KM145-6-TH	H	28/8	L200-4WD	4G63
KM145-6-THL	H	28/8	L200-4WD	4G63
KM145-7-E	H	25/8	PAJERO/MONTERO	4D56
KM145-7-EL	H	25/8	PAJERO/MONTERO	4D56
KM145-7-F	H	26/8	PAJERO/MONTERO	4D56
KM145-7-FL	H	26/8	PAJERO/MONTERO	4D56
KM145-7-TF	H	25/8	L200-4WD	4D56
KM147-3-J	J	30/8	L300-4WD	4G63
AUS KM132-I-F	C	26/8	L200-2WD	4G54
KM132-I-G	C	27/8	L200-2WD	4G54
KM135-9-P	C	18/5	L300-2WD	4G63
KM135-B-G	C	21/5	L300-2WD	4G64
KM145-7-TE	H	25/8	L200-4WD	4D56
KM145-8-TF	J	25/8	L200-4WD	4G54
KM145-9-FS	J	26/8	PAJERO/MONTERO	4G54
KM145-9-GS	J	27/8	PAJERO/MONTERO	4D56 turbocharger
KM147-5-F	J	26/8	L300-4WD	4D64
KM147-5-FS	J	26/8	L300-4WD	4G64

TRANSMISSION MODEL TABLE – MODEL 1988

Transmission Model	Gear ratio	Speedometer gear ratio	Vehicle Model	Engine Model
EC KM132-M-B	E	22/8	STARION	4G63 intercooler turbocharger
KM132-M-BL	E	22/8	STARION	4G63 intercooler turbocharger
KM132-M-BNL	E	22/8	STARION	G54B intercooler turbocharger
KM132-L-JL	D	30/8	L200-2WD	4G32
KM132-H-I	D	29/8	L200-2WD	4G63
KM132-H-IL	D	29/8	L200-2WD	4G63
KM132-J-F	D	26/8	L200-2WD	4D56
KM132-J-FL	D	26/8	L200-2WD	4D56
KM135-8-TF	D	17/5	L300-2WD (TRUCK)	4D56
KM135-9-T	C	18/5	L300-2WD (TRUCK)	4G32
KM135-B-GP	C	21/5	L300-2WD	4D56
KM135-5-A	D	15/5	L300-2WD	4G32
KM135-8-G	D	21/5	L300-2WD	4D56
KM135-9	C	18/5	L300-2WD	4G32
KM135-9-P	C	18/5	L300-2WD	4G63, G63B
KM135-9-PR	C	18/5	L300-2WD	G63B
KM145-6-TG	H	27/8	L200-4WD	4G63
KM145-6-TGL	H	27/8	L200-4WD	4G63
KM145-7-TE	H	25/8	L200-4WD	4D56
KM145-9-F	J	26/8	PAJERO/MONTERO	4D56 turbocharger
KM145-9-FL	J	26/8	PAJERO/MONTERO	4D56 turbocharger
KM145-9-G	J	27/8	PAJERO/MONTERO	4G54, 4D56 turbocharger
KM145-9-GL	J	27/8	PAJERO/MONTERO	4D56 turbocharger 4G54, G54B
KM147-3-MJR	J	30/8	L300-4WD	4G63
KM147-5-MF	J	26/8	L300-4WD	G64B
KM147-5-MGP	J	27/8	L300-4WD	4D56 turbocharger

Transmission Model	Gear ratio	Speedometer gear ratio	Vehicle Model	Engine Model	
EXP	KM130-6-I	A	29/8	L200-2WD	4G32
	KM130-6-IL	A	29/8	L200-2WD	4G32
	KM131-3	A	18/5	L300-2WD	4G32
	KM131-3-F	A	25/5	L300-2WD	4G32
	KM132-M-E	E	25/8	STARION	4G63 turbocharger
	KM132-M-EL	E	25/8	STARION	4G63 turbocharger
	KM132-J-E	D	25/8	L200-2WD	4D56
	KM132-J-EL	D	25/8	L200-2WD	4D56
	KM132-H-G	D	27/8	L200-2WD	4G63
	KM132-H-GL	D	27/8	L200-2WD	4G63
	KM135-B-GP	C	27/8	L300-2WD	4D56
	KM135-5-F	D	26/8	L300-2WD	4G32
	KM135-8-G	D	27/8	L300-2WD	4D56
	KM135-9-FP	C	26/8	L300-2WD	4G63
	KM145-7-D	H	24/8	PAJERO/MONTERO	4D56
	KM145-7-E	H	25/8	PAJERO/MONTERO	4D56
	KM145-7-F	H	26/8	PAJERO/MONTERO	4D56
	KM145-7-FL	H	26/8	PAJERO/MONTERO	4D56
	KM145-7-G	H	27/8	PAJERO/MONTERO	4D56
	KM145-7-TF	H	26/8	L200-4WD	4D56
	KM147-3-MJ	J	30/8	L300-4WD	4G63
AUS	KM132-I-G	C	27/8	L200-2WD	4G54
	KM132-I-F	C	26/8	L200-2WD	4G54
	KM135-B-G	C	21/5	L300-2WD	4G64
	KM135-B-GP	C	21/5	L300-2WD	4D56
	KM135-9-P	C	18/5	L300-2WD	4G63
	KM145-7-TE	H	25/8	L200-4WD	4D56
	KM145-8-TF	J	26/8	L200-4WD	4G54
	KM145-9-GS	J	27/8	PAJERO/MONTERO	4G54, 4D56 turbocharger
	KM147-5-MF	J	26/8	L300-4WD	4G64
	KM147-5-MFS	J	26/8	L300-4WD	4G64

TRANSMISSION MODEL TABLE – MODEL 1989

Transmission Model	Gear ratio	Speedometer gear ratio	Vehicle Model	Engine Model
EC KM131-3	A	18/5	L200-2WD	4G32
KM132-H-IW	D	29/8	L200-2WD	4G63
KM132-H-IWL	D	29/8	L200-2WD	4G63
KM132-J-FW	D	26/8	L200-2WD	4D56
KM132-J-FWL	D	26/8	L200-2WD	4D56
KM132-L-JWL	D	30/8	L200-2WD	4G32
KM132-N-BN	E	22/8	STARION	G54B intercooler turbocharger
KM132-N-BNL	E	22/8	STARION	G54B intercooler turbocharger
KM135-5-AW	D	15/5	L300-2WD	4G32
KM135-8-GW	D	21/5	L300-2WD	4D56
KM135-8-TF	D	17/5	L300-2WD (TRUCK)	4D56
KM135-9-PRW	C	18/5	L300-2WD	4G63
KM135-9-T	C	18/5	L300-2WD (TRUCK)	4G32
KM135-9-W	C	18/5	L300-2WD	4G32
KM135-9-GPW	C	21/5	L300-2WD	4D56
KM145-6-TG	H	27/8	L200-4WD	4G63
KM145-6-TGL	H	27/8	L200-4WD	4G63
KM145-7-TE	H	25/8	L200-4WD	4D56
KM145-B-GWL	I	27/8	PAJERO/MONTERO	4G54, G54B
KM147-6-JRW	J	30/8	L300-4WD	4G63
KM147-7-F	J	26/8	L300-4WD	4G64
KM147-7-GPW	J	27/8	L300-4WD	4D56 turbocharger

Transmission Model		Gear ratio	Speedometer gear ratio	Vehicle Model	Engine Model
EXP	KM130-6-I	A	29/8	L200-2WD	4G32
	KM130-6-IL	A	29/8	L200-2WD	4G32
	KM131-3	A	18/5	L300-2WD	4G32
	KM131-3-F	A	20/5	L300-2WD	4G32
	KM131-4	B	18/5	L300-2WD	4G33
	KM132-H-G	D	27/8	L200-2WD	4G63
	KM132-H-GL	D	27/8	L200-2WD	4G63
	KM132-J-E	D	25/8	L200-2WD	4D56
	KM132-J-EL	D	25/8	L200-2WD	4D56
	KM132-N-E	E	25/8	STARION	4G63 turbocharger
	KM132-N-EL	E	25/8	STARION	4G63 turbocharger
	KM145-A-D	G	24/8	PAJERO/MONTERO	4D56
	KM145-A-E	G	25/8	PAJERO/MONTERO	4D56
	KM145-A-F	G	26/8	PAJERO/MONTERO	4D56
	KM145-A-FL	G	26/8	PAJERO/MONTERO	4D56
	KM145-A-G	G	27/8	PAJERO/MONTERO	4D56
	KM145-A-GL	G	27/8	PAJERO/MONTERO	4D56
	KM145-A-TF	G	26/8	L200-4WD	4D56
	KM147-6-J	J	30/8	L300-4WD	4G63
	AUS	KM132-I-F	C	26/8	L200-2WD
KM132-J-F		D	26/8	L200-2WD	4D56
KM135-9-P		C	18/5	L300-2WD	4G63
KM135-B-G		C	21/5	L300-2WD	4G64
KM135-B-P		C	18/5	L300-2WD	4D56
KM145-A-TE		H	25/8	L200-4WD	4D56
KM145-B-G		I	27/8	PAJERO/MONTERO	4G54, 4D56 turbocharger
KM145-B-GS		I	27/8	PAJERO/MONTERO	4G54, 4D56 turbocharger
KM145-D-TE		I	25/8	L200-4WD	4G54
KM147-7-F		J	26/8	L300-4WD	4G64
KM147-7-FS		J	26/8	L300-4WD	4G64

TRANSMISSION MODEL TABLE – MODEL 1990

Transmission Model	Gear ratio	Speedometer gear ratio	Vehicle Model	Engine Model
EC KM132-H-IWL	D	29/8	L200-2WD	4G63
R5M21-1-BJWL	D	30/8	L200-2WD	4G32
R5M21-1-DIW	D	29/8	L200-2WD	4G63
R5M21-1-DIWL	D	29/8	L200-2WD	4G63
R5M21-1-PFW	D	26/8	L200-2WD	4D56
R5M21-1-PFWL	D	26/8	L200-2WD	4D56
R5M21-2-BEW	D	19/5	L300-2WD	4G32
R5M21-2-CDW	C	18/5	L300-2WD	4G32
R5M21-2-EDRW	C	18/5	L300-2WD	4G63
R5M21-2-PBW	C	16/5	L300-2WD	4D56
R5M21-2-QBW	C	16/5	L300-2WD	4D56
R5M21-3-CDW	C	24/8	L200-2WD (TRUCK)	4G32
R5M21-3-PC	D	23/8	L200-2WD (TRUCK)	4D56
R5M21-4-KB	E	22/8	STARION	G54B turbocharger
R5M21-4-KBL	E	22/8	STARION	G54B turbocharger
V5M21-1-DGW	H	27/8	L200-4WD	4G63
V5M21-1-DGWL	H	27/8	L200-4WD	4G63
V5M21-1-JEWL	H	25/8	L200-4WD	G54B
V5M21-1-PEW	H	25/8	L200-4WD	4D56
V5M21-2-EJRW	J	30/8	L300-4WD	4G63
V5M21-2-GFW	J	26/8	L300-4WD	4G64
V5M21-2-QGW	J	27/8	L300-4WD	4D56 turbocharger
V5M21-4-QFSL	J	26/8	PAJERO/MONTERO	4G54
V5M21-4-QGW	J	27/8	PAJERO/MONTERO	4G54
V5M21-4-QGWL	J	27/8	PAJERO/MONTERO	4G54, 4D56 intercooler turbocharger

Transmission Model	Gear ratio	Speedometer gear ratio	Vehicle Model	Engine Model
EXP R4M21-1-BI	A	29/8	L200-2WD	4G32
	R4M21-1-BIL	A	29/8	L200-2WD
R4M21-2-AD	B	18/5	L300-2WD	4G33
R4M21-2-BC	A	17/5	L300-2WD	4G32
R4M21-2-BD	A	18/5	L300-2WD	4G32
R5M21-1-DGL	D	27/8	L200-2WD	4G63
R5M21-1-PE	D	25/8	L200-2WD	4D56
R5M21-1-PEL	D	25/8	L200-2WD	4D56
R5M21-2-BC	A	17/5	L300-2WD	4G32
R5M21-2-EC	C	17/5	L300-2WD	4G63
R5M21-2-PB	C	16/5	L300-2WD	4D56
R5M21-2-QB	C	16/5	L300-2WD	4D56
R5M21-4-FE	E	25/8	STARION	4G63 turbocharger
R5M21-4-FEL	E	25/8	STARION	4G63 turbocharger
V5M21-1-DH	D	28/8	L200-4WD	4G63
V5M21-1-DHL	D	28/8	L200-4WD	4G63
V5M21-1-PF	D	26/8	L200-4WD	4D56
V5M21-2-EJ	J	30/8	L300-4WD	4G63
V5M21-4-PD	H	24/8	PAJERO/MONTERO	4D56
V5M21-4-PDL	H	24/8	PAJERO/MONTERO	4D56
V5M21-4-PF	H	26/8	PAJERO/MONTERO	4D56
V5M21-4-PFL	H	26/8	PAJERO/MONTERO	4D56
V5M21-4-QE	J	25/8	PAJERO/MONTERO	4G54, 4D56 turbocharger
V5M21-4-QEL	J	25/8	PAJERO/MONTERO	4G54, 4D56 turbocharger
V5M21-4-QG	J	27/8	PAJERO/MONTERO	4G54, 4D56 turbocharger
V5M21-4-QGL	J	27/8	PAJERO/MONTERO	4G54, 4D56 turbocharger
AUS R5M21-1-JF	C	26/8	L200-2WD	4G54
	R5M21-1-PF	D	26/8	L200-2WD
R5M21-2-ED	C	18/5	L300-2WD	4G63
R5M21-2-GB	C	16/5	L300-2WD	4D56
R5M21-2-PBW	C	16/5	L300-2WD	4G64
R5M21-2-QD	C	18/5	L300-2WD	4D56
V5M21-1-JE	J	25/8	L200-4WD	4G54
V5M21-1-PE	H	25/8	L200-4WD	4D56
V5M21-2-GF	J	26/8	L300-4WD	4G64
V5M21-2-GFS	J	26/8	L300-4WD	4G64
V5M21-4-QG	J	27/8	PAJERO/MONTERO	4G54, 4D56 turbocharger
V5M21-4-QGS	J	27/8	PAJERO/MONTERO	4G54, 4D56 turbocharger

TRANSMISSION MODEL TABLE – MODEL 1991

Transmission Model	Gear ratio	Speedometer gear ratio	Vehicle Model	Engine Model
EC R5M21-1-BJWL	D	30/8	L200-2WD	4G32
R5M21-1-DIW	D	29/8	L200-2WD	4G63
R5M21-1-DIWL	D	29/8	L200-2WD	4G63
R5M21-1-PFW	D	26/8	L200-2WD	4D56
R5M21-1-PFWL	D	26/8	L200-2WD	4D56
R5M21-2-BEW	D	19/5	L300-2WD	4G32
R5M21-2-CDW	C	18/5	L300-2WD	4G32
R5M21-2-EDRW	C	18/5	L300-2WD	4G63
R5M21-2-PBW	C	16/5	L300-2WD	4D56
R5M21-2-QBW	C	16/5	L300-2WD	4D56
R5M21-3-CDW	C	24/8	L200-2WD (TRUCK)	4G32
R5M21-3-PC	D	23/8	L200-2WD (TRUCK)	4D56
V5M21-1-DGW	H	27/8	L200-4WD	4G63
V5M21-1-DGWL	H	27/8	L200-4WD	4G63
V5M21-1-JEWL	H	25/8	L200-4WD	4D56
V5M21-1-PEW	H	25/8	L200-4WD	4D56
V5M21-1-PFW	H	26/8	L200-4WD	G54B
V5M21-2-EJRW	J	30/8	L300-4WD	4G63
V5M21-2-GFW	J	26/8	L300-4WD	4G64
V5M21-2-QGW	J	27/8	L300-4WD	4D56 turbocharger
V5M21-5-GGTL	J	27/8	PAJERO/MONTERO	4G64

22A-1-8b

MANUAL TRANSMISSION – Specifications

Transmission Model	Gear ratio	Speedometer gear ratio	Vehicle Model	Engine Model
EXP R4M21-1-BI	A	29/8	L200-2WD	4G32
R4M21-1-BIL	A	29/8	L200-2WD	4G32
R4M21-2-AD	B	18/5	L300-2WD	4G33
R4M21-2-AE	B	19/5	L300-2WD	4G33
R4M21-2-BD	A	18/5	L300-2WD	4G32
R5M21-1-DGL	D	17/5	L200-2WD	4G63
R5M21-1-JEL	D	25/5	L200-2WD	4G54
R5M21-1-PE	D	25/5	L200-2WD	4D56
R5M21-1-PEL	D	25/5	L200-2WD	4D56
R5M21-1-PFL	D	26/5	L200-2WD	4D56
R5M21-2-EC	C	17/5	L300-2WD	4G63
R5M21-2-EJ	C	24/5	L300-2WD	4G63
R5M21-2-PB	C	16/5	L300-2WD	4D56
R5M21-2-QB	C	16/5	L300-2WD	4D56
V5M21-1-DH	D	28/8	L200-4WD	4G63
V5M21-1-DHL	D	28/8	L200-4WD	4G63
V5M21-1-PE	D	25/8	L200-4WD	4D56
V5M21-1-PF	D	26/8	L200-4WD	4D56
V5M21-4-PD	H	24/8	PAJERO/MONTERO	4D56
V5M21-4-PDL	H	24/8	PAJERO/MONTERO	4D56
V5M21-4-PE	H	25/8	PAJERO/MONTERO	4D56
V5M21-4-PEL	H	25/8	PAJERO/MONTERO	4D56
V5M21-4-PF	H	26/8	PAJERO/MONTERO	4D56
V5M21-4-PFL	H	26/8	PAJERO/MONTERO	4D56
V5M21-4-PG	H	27/8	PAJERO/MONTERO	4D56
V5M21-4-PGL	H	27/8	PAJERO/MONTERO	4D56
V5M21-4-QE	J	25/8	PAJERO/MONTERO	4G54, 4D56 turbocharger
V5M21-4-QEL	J	25/8	PAJERO/MONTERO	4G54, 4D56 turbocharger
V5M21-4-QG	J	27/8	PAJERO/MONTERO	4G54, 4D56 turbocharger
V5M21-4-QGL	J	27/8	PAJERO/MONTERO	4G54, 4D56 turbocharger

Transmission Model	Gear ratio	Speedometer gear ratio	Vehicle Model	Engine Model
V5M21-5-PDT	H	24/8	PAJERO/MONTERO	4D56
V5M21-5-PDTL	H	24/8	PAJERO/MONTERO	4D56
V5M21-5-PET	H	25/8	PAJERO/MONTERO	4D56
V5M21-5-PETL	H	25/8	PAJERO/MONTERO	4D56
V5M21-5-PFT	H	26/8	PAJERO/MONTERO	4D56
V5M21-5-PFTL	H	26/8	PAJERO/MONTERO	4D56
V5M21-5-PGT	H	27/8	PAJERO/MONTERO	4D56
V5M21-5-PQTL	H	27/8	PAJERO/MONTERO	4D56
V5M21-5-QET	J	25/8	PAJERO/MONTERO	4G54
V5M21-5-QETL	J	25/8	PAJERO/MONTERO	4G54
V5M21-5-QGT	J	27/8	PAJERO/MONTERO	4G54
V5M21-5-QGTL	J	27/8	PAJERO/MONTERO	4G54
AUS R5M21-1-JF	C	26/8	L200-2WD	4G54
R5M21-1-PF	D	26/8	L200-2WD	4D56
R5M21-2-ED	C	18/5	L300-2WD	4G63
R5M21-2-GB	C	16/5	L300-2WD	4G64
R5M21-2-GF	C	26/5	L300-2WD	4G64
R5M21-2-GFS	C	26/5	L300-2WD	4G64
R5M21-2-PBW	C	16/5	L300-2WD	4D56
R5M21-2-QD	C	18/5	L300-2WD	4D56
V5M21-1-JE	J	25/8	L200-4WD	4G54
V5M21-1-QE	J	25/8	L200-4WD	4D56
V5M21-5-QGT	J	27/8	PAJERO	4G54

TRANSMISSION MODEL TABLE – MODEL 1992

Transmission Model	Gear ratio	Speedometer gear ratio	Vehicle Model	Engine Model
EC R5M21-1-BJWL	D	30/8	L200-2WD	4G32
R5M21-1-DIW	D	29/8	L200-2WD	4G63
R5M21-1-DIWL	D	29/8	L200-2WD	4G63
R5M21-1-PFW	D	26/8	L200-2WD	4D65
R5M21-1-PFWL	D	26/8	L200-2WD	4D65
R5M21-2-BEW	D	19/5	L300-2WD	4G32
R5M21-2-CDW	C	18/5	L300-2WD	4G32
R5M21-2-EDRW	C	18/5	L300-2WD	4G63
R5M21-2-GBW	C	16/5	L300-2WD	4G64
R5M21-2-GDW	C	18/5	L300-2WD	4G64
R5M21-2-PBW	C	16/5	L300-2WD	4D56
R5M21-2-QBW	C	16/5	L300-2WD	4D56
R5M21-3-PC	D	23/8	L200-2WD (TRUCK)	4D56
V5M21-1-DGW	D	27/8	L200-4WD	4G63
V5M21-1-DGWL	D	27/8	L200-4WD	4G63
V5M21-1-JEWL	H	25/8	L200-4WD	G54B
V5M21-1-PEW	D	25/8	L200-4WD	4D56
V5M21-1-PFW	D	26/8	L200-4WD	4D56
V5M21-2-EJRW	J	30/8	L300-4WD	4G63
V5M21-2-GFW	I	26/8	L300-4WD	4G64
V5M21-2-QGW	J	27/8	L300-4WD	4D56 turbocharger

Transmission Model	Gear ratio	Speedometer gear ratio	Vehicle Model	Engine Model
EXP R4M21-1-BI	A	29/8	L200-2WD	4G32
R4M21-1-BIL	A	29/8	L200-2WD	4G32
R4M21-2-AD	B	18/5	L300-2WD	4G33
R4M21-2-AE	B	19/5	L300-2WD	4G33
R4M21-2-BD	A	18/5	L300-2WD	4G32, 4D56
R5M21-1-BJWL	D	30/8	L200-2WD	4D56
R5M21-1-DGL	D	27/8	L200-2WD	4G63
R5M21-1-DIWL	D	29/8	L200-2WD	4D56
R5M21-1-JEL	C	25/8	L200-2WD	4G63
R5M21-1-PE	D	25/8	L200-2WD	4D56
R5M21-1-PEL	D	25/8	L200-2WD	4D56
R5M21-1-PFL	D	26/8	L200-2WD	4G63
R5M21-2-EC	C	17/5	L300-2WD	4G63
R5M21-2-PB	C	16/5	L300-2WD	4D56
R5M21-2-QB	C	16/5	L300-2WD	4D56
R5M21-2-QBW	C	16/5	L300-2WD	4D56
V5M21-2-EJ	J	30/8	L300-4WD	4G63
V5M21-5-PDT	H	24/8	PAJERO/MONTERO	4D56
V5M21-5-PDTL	H	24/8	PAJERO/MONTERO	4D56
V5M21-5-PET	H	25/8	PAJERO/MONTERO	4D56
V5M21-5-PETL	H	25/8	PAJERO/MONTERO	4D56
V5M21-5-PFT	H	26/8	PAJERO/MONTERO	4D56
V5M21-5-PFTL	H	26/8	PAJERO/MONTERO	4D56
V5M21-5-PGT	H	27/8	PAJERO/MONTERO	4D56
V5M21-5-PGTL	H	27/8	PAJERO/MONTERO	4D56
V5M21-5-QET	J	25/8	PAJERO/MONTERO	4G54
V5M21-5-QETL	J	25/8	PAJERO/MONTERO	4G54
V5M21-5-QGT	J	27/8	PAJERO/MONTERO	4G54
V5M21-5-QGTL	J	27/8	PAJERO/MONTERO	4G54

Transmission Model	Gear ratio	Speedometer gear ratio	Vehicle Model	Engine Model
AUS R5M21-1-JE	C	25/8	L200-2WD	4G54
R5M21-1-JF	C	26/8	L200-2WD	4G54
R5M21-1-PF	D	26/8	L200-2WD	4D56
R5M21-1-QE	D	25/8	L200-2WD	4D56
R5M21-1-QF	D	26/8	L200-2WD	4D56
R5M21-2-ED	C	18/5	L300-2WD	4G63
R5M21-2-GB	C	16/5	L300-2WD	4G64
R5M21-2-GD	C	18/5	L300-2WD	4G64
R5M21-2-GF	C	20/5	L300-2WD	4G64
R5M21-2-PBW	C	16/5	L300-2WD	4D56
R5M21-2-QD	C	18/5	L300-2WD	4D56

TRANSMISSION MODEL TABLE – MODEL 1993

Transmission Model	Gear ratio	Speedometer gear ratio	Vehicle Model	Engine Model
EC R5M21-1-BJWL	D	30/8	L200-2WD	4G32
R5M21-1-DIW	D	29/8	L200-2WD	4G63
R5M21-1-DIWL	D	29/8	L200-2WD	4G63
R5M21-1-PFW	D	26/8	L200-2WD	4D56
R5M21-1-PFWL	D	26/8	L200-2WD	4D56
R5M21-1-QEW	D	25/8	L200-2WD	4D56 turbocharger
R5M21-1-QFW	D	26/8	L200-2WD	4D56 turbocharger
R5M21-2-BEW	D	19/5	L300-2WD	4G32
R5M21-2-CDW	C	18/5	L300-2WD	4G32
R5M21-2-EDRW	C	18/5	L300-2WD	4G63
R5M21-2-GBW	C	16/5	L300-2WD	4G64
R5M21-2-GDW	C	18/5	L300-2WD	4G64
R5M21-2-PBW	C	16/5	L300-2WD	4D56
R5M21-2-QBW	C	16/5	L300-2WD	4D56
R5M21-3-CDW	C	18/5	L300-2WD (TRUCK)	4G32
R5M21-3-PC	D	17/5	L300-2WD (TRUCK)	4D56
V5M21-1-DGW	D	27/8	L200-4WD	4G63
V5M21-1-DGWL	D	27/8	L200-4WD	4G63
V5M21-1-DHWL	D	28/8	L200-4WD	4G63
V5M21-1-JEWL	H	25/8	L200-4WD	G54B
V5M21-1-QEW	J	25/8	L200-4WD	4D56
V5M21-1-QFW	J	26/8	L200-4WD	4D56
V5M21-2-GFW	I	26/8	L300-4WD	4G64
V5M21-2-QGW	J	27/8	L300-4WD	4D56
V5M21-5-GGTL	J	27/8	PAJERO/MONTERO	4G64

Transmission Model	Gear ratio	Speedometer gear ratio	Vehicle Model	Engine Model
EXP R4M21-1-BI	A	29/8	L200-2WD	4G32
R4M21-1-BIL	A	29/8	L200-2WD	4G32
R4M21-1-BJL	A	30/8	L200-2WD	4G32
R4M21-2-AD	B	18/5	L300-2WD	4G33
R4M21-2-AE	B	19/5	L300-2WD	4G33
R4M21-2-BD	A	18/5	L300-2WD	4G32
R4M21-2-BE	A	19/5	L300-2WD	4G32
R5M21-1-DGL	D	27/8	L200-2WD	4G63
R5M21-1-DIWL	D	29/8	L200-2WD	4G63
R5M21-1-JEL	J	25/8	L200-2WD	4G54
R5M21-1-JFL	J	26/8	L200-2WD	4G54
R5M21-1-PE	C	25/8	L200-2WD	4D56
R5M21-1-PEL	C	25/8	L200-2WD	4D56
R5M21-1-PF	C	26/8	L200-2WD	4D56
R5M21-1-PFL	C	26/8	L200-2WD	4D56
R5M21-2-EC	C	17/5	L300-2WD	4G63
R5M21-2-ED	C	18/5	L300-2WD	4G63
R5M21-2-GG	C	21/5	L300-2WD	4G64
R5M21-2-PB	C	16/5	L300-2WD	4D56
R5M21-2-QB	C	16/5	L300-2WD	4D56
V5M21-1-DGWL	D	27/8	L200-2WD	4G63
V5M21-1-DH	D	28/8	L200-2WD	4G63
V5M21-1-DHL	D	28/8	L200-2WD	4G63
V5M21-1-PE	D	25/8	L200-2WD	4D56
V5M21-1-PF	D	26/8	L200-2WD	4D56
V5M21-2-EJ	J	30/8	L300-4WD	4G63
V5M21-2-GG	I	27/8	L300-4WD	4G64
V5M21-5-PDL	H	24/8	PAJERO/MONTERO	4D56
V5M21-5-PDT	H	24/8	PAJERO/MONTERO	4D56
V5M21-5-PDTL	H	24/8	PAJERO/MONTERO	4D56
V5M21-5-PETL	H	25/8	PAJERO/MONTERO	4D56
V5M21-5-PFL	H	26/8	PAJERO/MONTERO	4D56
V5M21-5-PFT	H	26/8	PAJERO/MONTERO	4D56
V5M21-5-PFTL	H	26/8	PAJERO/MONTERO	4D56
V5M21-5-PGT	H	27/8	PAJERO/MONTERO	4D56
V5M21-5-PGTL	H	27/8	PAJERO/MONTERO	4D56
V5M21-5-QET	J	25/8	PAJERO/MONTERO	4G54
V5M21-5-QETL	J	25/8	PAJERO/MONTERO	4G54
V5M21-5-QFTL	J	26/8	PAJERO/MONTERO	4G54
V5M21-5-QGT	J	27/8	PAJERO/MONTERO	4G54
V5M21-5-QGTL	J	27/8	PAJERO/MONTERO	4G54

MANUAL TRANSMISSION – Specifications**22A-1-8i**

Transmission Model	Gear ratio	Speedometer gear ratio	Vehicle Model	Engine Model
AUS R5M21-1-JF	C	26/8	L200-2WD	4G54
R5M21-1-PF	D	26/8	L200-2WD	4D56
R5M21-2-ED	C	18/5	L300-2WD	4G63
R5M21-2-GB	C	16/5	L300-2WD	4G64
R5M21-2-GD	C	18/5	L300-2WD	4G64
R5M21-2-PBW	C	16/5	L300-2WD	4D56
R5M21-2-QD	C	18/5	L300-2WD	4D56
V5M21-2-GF	I	26/8	L300-4WD	4G64
V5M21-2-GFS	I	26/8	L300-4WD	4G64
V5M21-5-QGT	J	27/8	PAJERO	4G54, 4D56

TRANSMISSION MODEL TABLE – MODEL 1994

Transmission Model	Gear ratio	Speedometer gear ratio	Vehicle Model	Engine Model
EC R5M21-1-BJWL	D	30/8	L200-2WD	4G32
R5M21-1-DIW	D	29/8	L200-2WD	4G63
R5M21-1-DIWL	D	29/8	L200-2WD	4G63
R5M21-1-PFW	D	26/8	L200-2WD	4D56
R5M21-1-PFWL	D	26/8	L200-2WD	4D56
R5M21-2-BEW	D	19/5	L300-2WD	4G32
R5M21-2-CDW	C	18/5	L300-2WD	4G32
R5M21-2-EDRW	C	18/5	L300-2WD	4G63
R5M21-2-GBW	C	16/5	L300-2WD	4G64
R5M21-2-GDW	C	18/5	L300-2WD	4G64
R5M21-2-PBW	C	16/5	L300-2WD	4D56
R5M21-2-QBW	C	16/5	L300-2WD	4D56
R5M21-3-CDW	C	18/5	L300-2WD (TRUCK)	4G32
R5M21-3-PC	D	17/5	L300-2WD (TRUCK)	4D56
V5M21-1-DGWL	D	27/8	L200-4WD	4G63
V5M21-1-DHWL	D	28/8	L200-4WD	4G63
V5M21-1-JEWL	H	25/8	L200-4WD	G54B
V5M21-1-QEW	J	25/8	L200-4WD	4D56
V5M21-1-QFW	J	26/8	L200-4WD	4D56
V5M21-2-GFW	I	26/8	L300-4WD	4G64
V5M21-2-QGW	J	27/8	L300-4WD	4D56
V5M21-6-GGTL	J	27/8	PAJERO/MONTERO	4G64

MANUAL TRANSMISSION – Specifications

22A-1-8k

Transmission Model	Gear ratio	Speedometer gear ratio	Vehicle Model	Engine Model
EXP R4M21-1-BI	A	29/8	L200-2WD	4G32
R4M21-1-BIL	A	29/8	L200-2WD	4G32
R4M21-1-BJL	A	30/8	L200-2WD	4G32
R4M21-2-AD	B	18/5	L300-2WD	4G33
R4M21-2-AE	B	19/5	L300-2WD	4G33
R4M21-2-BD	A	18/5	L300-2WD	4G32
R4M21-2-BE	A	19/5	L300-2WD	4G32
R4M21-2-QB	C	16/5	L300-2WD	4G32
R5M21-1-DGL	D	27/8	L200-2WD	4G63
R5M21-1-DGWL	D	27/8	L200-2WD	4G63
R5M21-1-DH	D	28/8	L200-2WD	4G63
R5M21-1-DHL	D	28/8	L200-2WD	4G63
R5M21-1-DIWL	D	29/8	L200-2WD	4G63
R5M21-1-GEL	D	25/8	L200-2WD	4G64
R5M21-1-GFL	D	26/8	L200-2WD	4G64
R5M21-1-JEL	C	25/8	L200-2WD	4G54
R5M21-1-JFL	C	26/8	L200-2WD	4G54
R5M21-1-PE	D	25/8	L200-2WD	4D56
R5M21-1-PEL	D	25/8	L200-2WD	4D56
R5M21-1-PF	D	26/8	L200-2WD	4D56
R5M21-1-PFL	D	26/8	L200-2WD	4D56
R5M21-1-QE	D	25/8	L200-2WD	4D56
R5M21-2-EC	C	17/5	L300-2WD	4G63
R5M21-2-ED	C	18/5	L300-2WD	4G63
R5M21-2-GDW	C	18/5	L300-2WD	4G64
R5M21-2-PB	C	16/5	L300-2WD	4D56
R5M21-2-QB	C	16/5	L300-2WD	4D56
V5M21-1-DGWL	D	27/8	L200-4WD	4G63
V5M21-1-DH	D	28/8	L200-4WD	4G63
V5M21-1-DHL	D	28/8	L200-4WD	4G63
V5M21-1-GEL	D	25/8	L200-4WD	4G64
V5M21-1-GFL	D	26/8	L200-4WD	4G64
V5M21-1-PE	D	25/8	L200-4WD	4D56
V5M21-1-PF	D	26/8	L200-4WD	4D56
V5M21-1-QE	J	25/8	L200-4WD	4D56
V5M21-2-EJ	J	30/8	L300-4WD	4G63
V5M21-2-GG	I	27/8	L300-4WD	4G64

Transmission Model	Gear ratio	Speedometer gear ratio	Vehicle Model	Engine Model
EXP V5M21-6-PDT	H	24/8	PAJERO/MONTERO	4D56
V5M21-6-PDTL	H	24/8	PAJERO/MONTERO	4D56
V5M21-6-PFT	H	26/8	PAJERO/MONTERO	4D56
V5M21-6-PFTL	H	26/8	PAJERO/MONTERO	4D56
V5M21-6-QET	J	25/8	PAJERO/MONTERO	4G54
V5M21-6-QETL	J	25/8	PAJERO/MONTERO	4G54, 4D56
V5M21-6-QFTL	J	26/8	PAJERO/MONTERO	4D56
V5M21-6-QGT	J	27/8	PAJERO/MONTERO	4D56
V5M21-6-QGTL	J	27/8	PAJERO/MONTERO	4G54
V5M21-6-RET	H	25/8	PAJERO/MONTERO	4M40
V5M21-6-RETL	H	25/8	PAJERO/MONTERO	4M40
V5M21-6-RGT	H	27/8	PAJERO/MONTERO	4M40
V5M21-6-RGTL	H	27/8	PAJERO/MONTERO	4M40
AUS R5M21-1-JF	C	20/5	L200-2WD	4G54
R5M21-1-PF	D	20/5	L200-2WD	4D56
R5M21-2-ED	C	18/5	L300-2WD	4G63
R5M21-2-GB	C	16/5	L300-2WD	4G64
R5M21-2-GD	C	18/5	L300-2WD	4G64
R5M21-2-PBW	C	16/5	L300-2WD	4D56
R5M21-2-QD	C	18/5	L300-2WD	4D56
V5M21-1-JE	H	26/8	L200-4WD	4G54
V5M21-1-QE	J	25/8	L200-4WD	4D56
V5M21-1-QF	J	26/8	L200-4WD	4D56
V5M21-2-GF	I	26/8	L300-4WD	4G64
V5M21-2-GFS	I	26/8	L300-4WD	4G64
V5M21-6-RGT	H	27/8	PAJERO	4M40

TRANSMISSION MODEL TABLE – MODEL 1995

Transmission Model	Gear ratio	Speedometer gear ratio	Vehicle Model	Engine Model	
EC	R5M21-1-DICL	D	29/8	L200-2WD	4G63
	R5M21-1-GFCL	D	26/8	L200-2WD	4G64
	R5M21-1-PFC	D	26/8	L200-2WD	4D56
	R5M21-1-PFCL	D	26/8	L200-2WD	4D56
R5M21-2-EEC	R5M21-2-EEC	C	19/5	L300-2WD	4G63
	R5M21-2-PBC	C	16/5	L300-2WD	4D56
	R5M21-2-QBC	C	16/5	L300-2WD	4D56
R5M21-7-EJ	R5M21-7-EJ	C	30/8	L400-2WD	4G63
	R5M21-7-EJDL	C	30/8	L400-2WD	4G63
	R5M21-7-EJL	C	30/8	L400-2WD	4G63
	R5M21-7-GHDL	C	28/8	L400-2WD	4G64
	R5M21-7-QF	C	26/8	L400-2WD	4D56
R5M21-8-EE	R5M21-8-EE	C	19/5	L300-2WD	4G63
	R5M21-8-QD	C	18/5	L300-2WD	4D56
V5M21-1-GGCL	V5M21-1-GGCL	D	27/8	L200-4WD	4G64
	V5M21-1-GHCL	D	28/8	L200-4WD	4G64
	V5M21-1-JF	H	26/8	L200-4WD	4G54
	V5M21-1-QEC	J	25/8	L200-4WD	4D56
	V5M21-1-QFC	J	26/8	L200-4WD	4D56
	V5M21-1-QGWL	J	27/8	L200-4WD	4G54
V5M21-2-QGC	J	27/8	L300-4WD	4D56	
V5M21-7-GGTL	V5M21-7-GGTL	I	27/8	L400-4WD	4G64
	V5M21-7-QGTL	I	27/8	L400-4WD	4D56

Transmission Model	Gear ratio	Speedometer gear ratio	Vehicle Model	Engine Model
EXP R4M21-1-BI	A	29/8	L200-2WD	4G32
R4M21-1-BIL	A	29/8	L200-2WD	4G32
R4M21-1-BJL	A	30/8	L200-2WD	4G32
R5M21-1-DGAL	D	27/8	L200-2WD	4G63
R5M21-1-DICL	D	29/8	L200-2WD	4G63
R5M21-1-GEAL	D	25/8	L200-2WD	4G64
R5M21-1-GFCL	D	26/8	L200-2WD	4G64
R5M21-1-JEAL	H	25/8	L200-2WD	4G54
R5M21-1-PEA	D	25/8	L200-2WD	4D56
R5M21-1-PEAL	D	25/8	L200-2WD	4D56
R5M21-1-PFC	D	26/8	L200-2WD	4D56
R5M21-1-PFCL	D	26/8	L200-2WD	4D56
R5M21-2-BFA	D	20/5	L300-2WD	4G92
R5M21-2-DA	D	15/5	L300-2WD	4G63
R5M21-2-DEA	D	19/5	L300-2WD	4G63
R5M21-2-EDA	C	18/5	L300-2WD	4G63
R5M21-2-EEA	C	19/5	L300-2WD	4G63
R5M21-2-PBA	C	16/5	L300-2WD	4D56
R5M21-2-QBA	C	16/5	L300-2WD	4D56
R5M21-7-EJ	C	30/8	L400-2WD	4G63
R5M21-7-EJL	C	30/8	L400-2WD	4G63
R5M21-7-GI	C	29/8	L400-2WD	4G64
R5M21-7-QF	C	26/8	L400-2WD	4D56
R5M21-7-QI	C	29/8	L400-2WD	4D56
V5M21-1-DGCL	D	27/8	L200-4WD	4G63
V5M21-1-DHA	D	28/8	L200-4WD	4G63
V5M21-1-DHCL	D	28/8	L200-4WD	4G63
V5M21-1-GEAL	D	26/8	L200-4WD	4G64
V5M21-1-PEA	D	25/8	L200-4WD	4D56
V5M21-1-PFA	D	26/8	L200-4WD	4D56
V5M21-1-QEC	J	25/8	L200-4WD	4D56
V5M21-1-QFC	J	26/8	L200-4WD	4D56
V5M21-2-EJA	J	30/8	L300-4WD	4G63

Transmission Model	Gear ratio	Speedometer gear ratio	Vehicle Model	Engine Model
EXP V5M21-6-PDA	H	24/8	PAJERO/MONTERO	4D56
V5M21-6-PDAL	H	24/8	PAJERO/MONTERO	4D56
V5M21-6-PEA	H	25/8	PAJERO/MONTERO	4D56
V5M21-6-PEAL	H	25/8	PAJERO/MONTERO	4D56
V5M21-6-PFA	H	26/8	PAJERO/MONTERO	4D56
V5M21-6-PFAL	H	26/8	PAJERO/MONTERO	4D56
V5M21-6-PGA	H	27/8	PAJERO/MONTERO	4D56
V5M21-6-PGAL	H	27/8	PAJERO/MONTERO	4D56
V5M21-6-QEA	J	25/8	PAJERO/MONTERO	4G54
V5M21-6-QEAL	J	25/8	PAJERO/MONTERO	4G54
V5M21-6-QGA	J	27/8	PAJERO/MONTERO	4G54
V5M21-6-QGAL	J	27/8	PAJERO/MONTERO	4G54
V5M21-6-REA	H	25/8	PAJERO/MONTERO	4D56
V5M21-6-REAL	H	25/8	PAJERO/MONTERO	4D56
V5M21-6-RGA	H	27/8	PAJERO/MONTERO	4D56
V5M21-6-RGAL	H	27/8	PAJERO/MONTERO	4D56
V5M21-7-EJT	I	30/8	L400-4WD	4G63
V5M21-7-EJTL	I	30/8	L400-4WD	4G63
V5M21-7-GGT	I	27/8	L400-4WD	4G64
AUS R5M21-1-JFC	H	26/8	L200-2WD	4G54
R5M21-1-PFC	D	26/8	L200-2WD	4D56
R5M21-2-EEA	C	19/5	L300-2WD	4G63
R5M21-2-GDA	C	18/5	L300-2WD	4G64
R5M21-2-PBC	C	16/5	L300-2WD	4D56
R5M21-2-QBC	C	16/5	L300-2WD	4D56
R5M21-7-EJD	C	30/8	L400-2WD	4G63
R5M21-7-GHD	C	28/8	L400-2WD	4G64
R5M21-7-GID	C	29/8	L400-2WD	4G64
V5M21-1-JEC	H	25/8	L200-4WD	4G54
V5M21-1-QEC	J	25/8	L200-4WD	4D56
V5M21-1-QFC	J	26/8	L200-4WD	4D56
V5M21-2-GGA	I	27/8	L300-4WD	4G64
V5M21-6-RGA	H	27/8	PAJERO	4M40

TRANSMISSION MODEL TABLE – MODEL 1996

Transmission Model	Gear ratio	Speedometer gear ratio	Vehicle Model	Engine Model
EC R5M21-1-GFCL	D	26/8	L200-2WD	4G64
R5M21-1-PFC	D	26/8	L200-2WD	4D56
R5M21-1-PFCL	D	26/8	L200-2WD	4D56
R5M21-2-EEC	C	25/8	L300-2WD	4G63
R5M21-2-PBC	C	22/8	L300-2WD	4D56
R5M21-2-QBC	C	22/8	L300-2WD	4D56
R5M21-2-QGC	C	27/8	L300-2WD	4D56
R5M21-7-EJ	C	30/8	L400-2WD	4G63
R5M21-7-EJDL	C	30/8	L400-2WD	4G63
R5M21-7-EJL	C	30/8	L400-2WD	4G63
R5M21-7-GHDL	C	28/8	L400-2WD	4G64
R5M21-7-QF	C	26/8	L400-2WD	4D56
R5M21-8-EE	C	19/5	L300-2WD (TRUCK)	4G63
R5M21-8-QD	C	18/5	L300-2WD (TRUCK)	4D56
V5M21-1-GGLC	D	27/8	L200-4WD	4G64
V5M21-1-GHCL	D	28/8	L200-4WD	4G64
V5M21-1-QEC	J	25/8	L200-4WD	4D56
V5M21-1-QFC	J	26/8	L200-4WD	4D56
V5M21-7-GGTL	I	27/8	L400-4WD	4G64
V5M21-7-QGTL	I	27/8	L400-4WD	4D56

Transmission Model	Gear ratio	Speedometer gear ratio	Vehicle Model	Engine Model
EXP R4M21-1-BI	A	29/8	L200-2WD	4G32
R4M21-1-BIL	A	29/8	L200-2WD	4G32
R4M21-1-BJL	A	30/8	L200-2WD	4G32
R5M21-1-DGA	D	27/8	L200-2WD	4G63
R5M21-1-DGAL	D	27/8	L200-2WD	4G63
R5M21-1-DIC	D	29/8	L200-2WD	4G63
R5M21-1-DICL	D	29/8	L200-2WD	4G63
R5M21-1-GEAL	D	25/8	L200-2WD	4G64
R5M21-1-GFCL	D	26/8	L200-2WD	4G64
R5M21-1-JEAL	H	25/8	L200-2WD	4G54
R5M21-1-PEA	D	25/8	L200-2WD	4D56
R5M21-1-PEAL	D	25/8	L200-2WD	4D56
R5M21-1-PFC	D	26/8	L200-2WD	4D56
R5M21-1-PFCL	D	26/8	L200-2WD	4D56
R5M21-2-BFA	D	20/5	L300-2WD	4G92
R5M21-2-DDA	D	18/5	L300-2WD	4G63
R5M21-2-DEA	D	19/5	L300-2WD	4G63
R5M21-2-EC	C	17/5	L300-2WD	4G63
R5M21-2-ED	C	18/5	L300-2WD	4G63
R5M21-2-EDA	C	18/5	L300-2WD	4G63
R5M21-2-EEA	C	19/5	L300-2WD	4G63
R5M21-2-PBA	C	16/5	L300-2WD	4D56
R5M21-2-QBA	C	16/5	L300-2WD	4D56
R5M21-7-EJ	C	30/8	L400-2WD	4G63
R5M21-7-EJDL	C	30/8	L400-2WD	4G63
R5M21-7-EJL	C	30/8	L400-2WD	4G63
R5M21-7-EJT	C	30/8	L400-2WD	4G63
R5M21-7-EJTL	C	30/8	L400-2WD	4G63
R5M21-7-GGT	C	27/8	L400-2WD	4G64
R5M21-7-GGTL	C	27/8	L400-2WD	4G64
R5M21-7-GI	C	29/8	L400-2WD	4G64
R5M21-7-QF	C	26/8	L400-2WD	4D56
R5M21-7-QGTL	C	27/8	L400-2WD	4D56
R5M21-7-QI	C	29/8	L400-2WD	4D56

Transmission Model	Gear ratio	Speedometer gear ratio	Vehicle Model	Engine Model
EXP V5M21-1-DGCL	D	27/8	L200-4WD	4G63
V5M21-1-DHA	D	28/8	L200-4WD	4G63
V5M21-1-DHCL	D	28/8	L200-4WD	4G63
V5M21-1-GEAL	D	25/8	L200-4WD	4G64
V5M21-1-GFAL	D	26/8	L200-4WD	4G64
V5M21-1-PEA	D	25/8	L200-4WD	4D56
V5M21-1-PFA	D	26/8	L200-4WD	4D56
V5M21-1-QEC	J	25/8	L200-4WD	4D56
V5M21-1-QFC	J	26/8	L200-4WD	4D56
V5M21-2-EJ	J	30/8	L300-4WD	4G63
V5M21-2-EJA	J	30/8	L300-4WD	4G63
V5M21-6-GQA	J	27/8	PAJERO/MONTERO	4G54
V5M21-6-IEAL	J	25/8	PAJERO/MONTERO	4G54
V5M21-6-IGAL	J	27/8	PAJERO/MONTERO	4G54
V5M21-6-PDA	H	24/8	PAJERO/MONTERO	4D56
V5M21-6-PDAL	H	24/8	PAJERO/MONTERO	4D56
V5M21-6-PEA	H	25/8	PAJERO/MONTERO	4D56
V5M21-6-PEAL	H	25/8	PAJERO/MONTERO	4D56
V5M21-6-PFA	H	26/8	PAJERO/MONTERO	4D56
V5M21-6-PFAL	H	26/8	PAJERO/MONTERO	4D56
V5M21-6-PGA	H	27/8	PAJERO/MONTERO	4D56
V5M21-6-QEA	J	25/8	PAJERO/MONTERO	4G54
V5M21-6-QEAL	J	25/8	PAJERO/MONTERO	4G54
V5M21-6-QGAL	J	27/8	PAJERO/MONTERO	4G54
V5M21-7-EJT	I	30/8	L400-4WD	4G63
V5M21-7-EJTL	I	30/8	L400-4WD	4G63
V5M21-7-GGT	I	27/8	L400-4WD	4G64
V5M21-7-QGTL	I	27/8	L400-4WD	4D56

MANUAL TRANSMISSION – Specifications**22A-1-8s**

Transmission Model	Gear ratio	Speedometer gear ratio	Vehicle Model	Engine Model
AUS R5M21-1-JFC	H	26/8	L200-2WD	4G54
R5M21-1-PFC	D	26/8	L200-2WD	4D56
R5M21-2-ED	C	18/5	L300-2WD	4G63
R5M21-2-EEA	C	19/5	L300-2WD	4G63
R5M21-2-GDA	C	18/5	L300-2WD	4G64
R5M21-2-PBC	C	16/5	L300-2WD	4D56
R5M21-2-QBC	C	16/5	L300-2WD	4D56
R5M21-7-EJD	C	30/8	L400-2WD	4G63
R5M21-7-GHD	C	28/8	L400-2WD	4G64
R5M21-7-GID	C	29/8	L400-2WD	4G64
V5M21-1-JEC	H	25/8	L200-4WD	4G54
V5M21-1-QEC	J	25/8	L200-4WD	4D56
V5M21-1-QFC	J	26/8	L200-4WD	4D56
V5M21-6-RGA	H	27/8	PAJERO	4M40

TRANSMISSION MODEL TABLE – MODEL 1997

Transmission Model	Gear ratio	Speedometer gear ratio	Vehicle Model	Engine Model	
EC	R5M21-1-GFCL	D	26/8	L200-2WD	4G64
	R5M21-1-PFCL	D	26/8	L200-2WD	4D56
	R5M21-2-EEC5	C	19/5	L300-2WD	4G63
	R5M21-2-PAC5	C	15/5	L300-2WD	4D56
	R5M21-2-QAC5	C	15/5	L300-2WD	4D56
	R5M21-5-DIF4	D	29/8	L200-2WD	4G63
	R5M21-5-PF4	D	26/8	L200-2WD	4D56
	R5M21-5-PF5	D	26/8	L200-2WD	4D56
	R5M21-7-EJ	C	30/8	L400-2WD	4G63
	R5M21-7-EJDL	C	30/8	L400-2WD	4G63
	R5M21-7-EJL	C	30/8	L400-2WD	4G63
	R5M21-7-GHD4	C	28/8	L400-2WD	4G64
	R5M21-7-GID4	C	29/8	L400-2WD	4G64
	R5M21-7-GHD5	C	28/8	L400-2WD	4G64
	R5M21-7-GID5	C	29/8	L400-2WD	4G64
R5M21-7-QF4	C	26/8	L400-2WD	4D56	
R5M21-8-EE5	C	25/8	L300-2WD (TRUCK)	4G63	
R5M21-8-QD5	C	24/8	L300-2WD (TRUCK)	4D56	
V5M21-1-GGCL	D	27/8	L200-4WD	4G64	
V5M21-1-GHCL	D	28/8	L200-4WD	4G64	
V5M21-1-QEC	J	25/8	L200-4WD	4D56	
V5M21-1-QFC	J	26/8	L200-4WD	4D56	
V5M21-2-QGC5	J	27/8	L300-4WD	4D56	
V5M21-7-GGT4	I	27/8	L400-4WD	4G64	
V5M21-7-QGT4	I	27/8	L400-4WD	4D56	
V5M21-9-GG4	I	27/8	L200-4WD	4G64	
EXP	R5M21-1-DGA	D	27/8	L200-2WD	4G63
	R5M21-1-DGAL	D	27/8	L200-2WD	4G63
	R5M21-1-DICL	D	29/8	L200-2WD	4G63
	R5M21-1-DIC	D	29/8	L200-2WD	4G63
	R5M21-1-GEAL	D	25/8	L200-2WD	4G64
	R5M21-1-GFCL	D	26/8	L200-2WD	4G64
	R5M21-1-JEAL	H	25/8	L200-2WD	4G54
	R5M21-1-JFAL	H	26/8	L200-2WD	4G54
	R5M21-1-PEA	D	25/8	L200-2WD	4D56
	R5M21-1-PEAL	D	25/8	L200-2WD	4D56
	R5M21-1-PFC	D	26/8	L200-2WD	4D56
	R5M21-1-PFCL	D	26/8	L200-2WD	4D56

Transmission Model	Gear ratio	Speedometer gear ratio	Vehicle Model	Engine Model
EXP R5M21-2-BFAP	D	20/5	L300-2WD	4G92
R5M21-2-DDAP	D	18/5	L300-2WD	4G63
R5M21-2-DEAP	D	19/5	L300-2WD	4G63
R5M21-2-EDAP	C	18/5	L300-2WD	4G63
R5M21-2-EEAP	C	19/5	L300-2WD	4G63
R5M21-2-PBAP	C	16/5	L300-2WD	4D56
R5M21-2-QBAP	C	16/5	L300-2WD	4D56
R5M21-5-DI4	D	29/8	L200-2WD	4G63
R5M21-5-DI5	D	29/8	L200-2WD	4G63
R5M21-5-PF4	D	26/8	L200-2WD	4D56
R5M21-5-PF5	D	26/8	L200-2WD	4D56
R5M21-7-EJL	C	30/8	L400-2WD	4G63
R5M21-7-EJ	C	30/8	L400-2WD	4G63
R5M21-7-GI5	C	29/8	L400-2WD	4G64
R5M21-7-GID4	C	29/8	L400-2WD	4G64
R5M21-7-PFC	C	26/8	L400-2WD	4D56
R5M21-7-QI5	C	29/8	L400-2WD	4D56
R5M21-7-QF4	C	26/8	L400-2WD	4D56
V5M21-1-DHCL	G	28/8	L200-4WD	4G63
V5M21-1-DGCL	G	27/8	L200-4WD	4G63
V5M21-1-DHA	G	28/8	L200-4WD	4G63
V5M21-1-GFAL	G	26/8	L200-4WD	4G64
V5M21-1-GEAL	G	25/8	L200-4WD	4G64
V5M21-1-PFA	G	26/8	L200-4WD	4D56
V5M21-1-PEA	G	25/8	L200-4WD	4D56
V5M21-1-QEC	J	25/8	L200-4WD	4D56
V5M21-1-QFC	J	26/8	L200-4WD	4D56
V5M21-2-EJA	J	30/8	L300-4WD	4G63
V5M21-6-GGKL	H	27/8	PAJERO/MONTERO	4G64
V5M21-6-GEK	H	25/8	PAJERO/MONTERO	4G64
V5M21-6-GEKL	H	25/8	PAJERO/MONTERO	4G64
V5M21-6-GGK	H	27/8	PAJERO/MONTERO	4G64
V5M21-6-IEK	H	25/8	PAJERO/MONTERO	4G64
V5M21-6-IEKL	H	25/8	PAJERO/MONTERO	4G64
V5M21-6-IGK	H	27/8	PAJERO/MONTERO	4G64
V5M21-6-IGKL	H	27/8	PAJERO/MONTERO	4G64
V5M21-6-PDA4	H	24/8	PAJERO/MONTERO	4D56
V5M21-6-PDA5	H	24/8	PAJERO/MONTERO	4D56
V5M21-6-PEA5	H	25/8	PAJERO/MONTERO	4D56
V5M21-6-PFA4	H	26/8	PAJERO/MONTERO	4D56
V5M21-6-PFA5	H	26/8	PAJERO/MONTERO	4D56
V5M21-6-PGA4	H	27/8	PAJERO/MONTERO	4D56
V5M21-6-PGA5	H	27/8	PAJERO/MONTERO	4D56

Transmission Model	Gear ratio	Speedometer gear ratio	Vehicle Model	Engine Model
EXP V5M21-7-EJTL	I	30/8	L400-4WD	4G64
V5M21-7-EJT	I	30/8	L400-4WD	4G63
V5M21-7-GGT4	I	27/8	L400-4WD	4G64
V5M21-7-GGT5	I	27/8	L400-4WD	4G64
V5M21-7-QGT4	I	27/8	L400-4WD	4D56
V5M21-9-DI4	I	29/8	L200-4WD	4G63
V5M21-9-DI5	I	29/8	L200-4WD	4G63
V5M21-9-GG4	I	27/8	L200-4WD	4G64
V5M21-9-PG4	I	27/8	L200-4WD	4D56
V5M21-9-PG5	I	27/8	L200-4WD	4D56
MMAL R5M21-2-EDI	C	18/5	L300-2WD	4G63
R5M21-2-EEA	C	19/5	L300-2WD	4G63
R5M21-2-GDA5	C	20/5	L300-2WD	4G64
R5M21-2-PBC5	C	16/5	L300-2WD	4D56
R5M21-2-QBC5	C	16/5	L300-2WD	4D56
R5M21-5-GF	D	26/8	L200-2WD	4G64
R5M21-5-GF5	D	20/5	L200-2WD	4G64
R5M21-7-EJD	C	30/8	L400-2WD	4G63
R5M21-7-GHD5	C	28/8	L400-2WD	4G64
R5M21-7-GID5	C	29/8	L400-2WD	4G64
V5M21-2-GGA5	I	27/8	L300-4WD	4G64

TRANSMISSION MODEL TABLE – MODEL 1998

Transmission Model	Gear ratio	Speedometer gear ratio	Vehicle Model	Engine Model	
EC	R5M21-2-EECP	C	19/5	L300-2WD	4G63
	R5M21-2-PACP	C	15/5	L300-2WD	4D56
	R5M21-2-QACP	C	15/5	L300-2WD	4D56
	R5M21-5-DIF4	D	29/8	L200-2WD	4G63
	R5M21-5-PF4	D	26/8	L200-2WD	4D56
	R5M21-5-PF5	D	26/8	L200-2WD	4D56
	R5M21-7-EJ	C	30/8	L400-2WD	4G63
	R5M21-7-EJDL	C	30/8	L400-2WD	4G63
	R5M21-7-EJL	C	30/8	L400-2WD	4G63
	R5M21-7-GHD4	C	28/8	L400-2WD	4G64
	R5M21-7-GHD5	C	28/8	L400-2WD	4G64
	R5M21-7-GID4	C	29/8	L400-2WD	4G64
	R5M21-7-GID5	C	29/8	L400-2WD	4G64
	R5M21-7-QF4	C	26/8	L400-2WD	4D56
	R5M21-8-EE5	C	25/8	L300-2WD (TRUCK)	4G63
	R5M21-8-QD5	C	24/8	L300-2WD (TRUCK)	4D56
	V5M21-2-QGC5	J	27/8	L300-4WD	4D56
	V5M21-7-GGT4	I	27/8	L400-4WD	4G64
	V5M21-7-QGT4	I	27/8	L400-4WD	4D56
	V5M21-9-GG4	I	27/8	L200-4WD	4G64
EXP	R5M21-2-BFAP	D	20/5	L300-2WD	4G92
	R5M21-2-DDAP	D	18/5	L300-2WD	4G63
	R5M21-2-DEAP	D	19/5	L300-2WD	4G63
	R5M21-2-EDAP	C	18/5	L300-2WD	4G63
	R5M21-2-EEAP	C	19/5	L300-2WD	4G63
	R5M21-2-QBAP	C	16/5	L300-2WD	4D56
	R5M21-5-PF5	D	26/8	L200-2WD	4D56
	R5M21-7-EJ	C	30/8	L400-2WD	4G63
	R5M21-7-EJL	C	30/8	L400-2WD	4G63
	R5M21-7-GID4	C	29/8	L400-2WD	4G64
R5M21-7-QF4	C	26/8	L400-2WD	4D56	
V5M21-2-EJA	J	30/8	L300-4WD	4G63	

Transmission Model	Gear ratio	Speedometer gear ratio	Vehicle Model	Engine Model
EXP V5M21-6-GEK	H	25/8	PAJERO/MONTERO	4G64
V5M21-6-GEKL	H	25/8	PAJERO/MONTERO	4G64
V5M21-6-GGK	H	27/8	PAJERO/MONTERO	4G64
V5M21-6-GGKL	H	27/8	PAJERO/MONTERO	4G64
V5M21-6-IEK	H	25/8	PAJERO/MONTERO	4G64
V5M21-6-IEKL	H	25/8	PAJERO/MONTERO	4G64
V5M21-6-IGK	H	27/8	PAJERO/MONTERO	4G64
V5M21-6-IGKL	H	27/8	PAJERO/MONTERO	4G64
V5M21-6-PDA4	H	24/8	PAJERO/MONTERO	4D56
V5M21-6-PDA5	H	24/8	PAJERO/MONTERO	4D56
V5M21-6-PEA4	H	25/8	PAJERO/MONTERO	4D56
V5M21-6-PEA5	H	25/8	PAJERO/MONTERO	4D56
V5M21-6-PFA4	H	26/8	PAJERO/MONTERO	4D56
V5M21-6-PFA5	H	26/8	PAJERO/MONTERO	4D56
V5M21-6-PGA4	H	27/8	PAJERO/MONTERO	4D56
V5M21-6-PGA5	H	27/8	PAJERO/MONTERO	4D56
V5M21-7-EJT	I	30/8	L400-4WD	4G63
V5M21-7-EJTL	I	30/8	L400-4WD	4G64
V5M21-7-GGT4	I	27/8	L400-4WD	4G64
V5M21-7-GGT5	I	27/8	L400-4WD	4G64
V5M21-7-QGT4	I	27/8	L400-4WD	4D56
MMAL R5M21-2-EEA	C	19/5	L300-2WD	4G63
R5M21-2-GDA5	C	20/5	L300-2WD	4G64
R5M21-2-PBC5	C	16/5	L300-2WD	4D56
R5M21-2-QBC5	C	16/5	L300-2WD	4D56
R5M21-5-GF5	D	20/5	L200-2WD	4G64
R5M21-7-EJD	C	30/8	L400-2WD	4G63
R5M21-7-GHD5	C	28/8	L400-2WD	4G64
R5M21-7-GID5	C	29/8	L400-2WD	4G64
V5M21-2-GGA5	I	27/8	L300-4WD	4G64

TRANSMISSION MODEL TABLE – MODEL 1999

Transmission Model	Gear ratio	Speedometer gear ratio	Vehicle Model	Engine Model	
EUR	R5M21-2-EECP	C	19/5	L300-2WD	4G63
	R5M21-2-PACP	C	15/5	L300-2WD	4D56
	R5M21-2-QACP	C	15/5	L300-2WD	4D56
	R5M21-5-DIF4	D	29/8	L200-2WD	4G63
	R5M21-5-PF4	D	26/8	L200-2WD	4D56
	R5M21-5-PF5	D	26/8	L200-2WD	4D56
	R5M21-7-EJ	C	30/8	L400-2WD	4G63
	R5M21-7-EJDL	C	30/8	L400-2WD	4G63
	R5M21-7-EJL	C	30/8	L400-2WD	4G63
	R5M21-7-GHD4	C	28/8	L400-2WD	4G64
	R5M21-7-GID4	C	29/8	L400-2WD	4G64
	R5M21-7-QF4	C	26/8	L400-2WD	4D56
	R5M21-8-EE5	C	25/8	L300-2WD (TRUCK)	4G63
	R5M21-8-QD5	C	24/8	L300-2WD (TRUCK)	4D56
	V5M21-2-QGC5	J	27/8	L300-4WD	4D56
	V5M21-7-GGT4	I	27/8	L400-4WD	4G64
	V5M21-7-QGT4	I	27/8	L400-4WD	4D56
	V5M21-9-GG4	I	27/8	L200-4WD	4G64
	V5M21-A-HG	K	–	PAJERO-IO	4G93
EXP	R5M21-2-BFAP	D	20/5	L300-2WD	4G92
	R5M21-2-DDAP	D	18/5	L300-2WD	4G63
	R5M21-2-DEAP	D	19/5	L300-2WD	4G63
	R5M21-2-EDAP	C	18/5	L300-2WD	4G63
	R5M21-2-EEAP	C	19/5	L300-2WD	4G63
	R5M21-2-PBAP	D	16/5	L300-2WD	4D56
	R5M21-2-QBAP	C	16/5	L300-2WD	4D56
	R5M21-5-PF5	D	26/8	L200-2WD	4D56
	R5M21-5-DI4	D	29/8	L200-2WD	4G63
	R5M21-5-DI5	D	29/8	L200-2WD	4G63
	R5M21-5-DIF4	D	29/8	L200-2WD	4G63
	R5M21-5-PF4	D	26/8	L200-2WD	4D56
	R5M21-5-TF5	D	26/8	L200-2WD	4M40
	R5M21-5-GF4	C	26/8	L200-2WD	4G64
	R5M21-7-EJ	C	30/8	L400-2WD	4G63
	R5M21-7-EJL	C	30/8	L400-2WD	4G63
	R5M21-7-GID4	C	29/8	L400-2WD	4G64
	R5M21-7-QF4	C	26/8	L400-2WD	4D56
	V5M21-2-EJA	J	30/8	L300-4WD	4G63
	V5M21-9-DI4	G	29/8	L200-4WD	4G63
	V5M21-9-DI5	G	29/8	L200-4WD	4G63
	V5M21-9-GG4	I	27/8	L200-4WD	4G64

Transmission Model	Gear ratio	Speedometer gear ratio	Vehicle Model	Engine Model
EXP V5M21-9-PG4	G	27/8	L200-4WD	4D56
V5M21-9-PG5	G	27/8	L200-4WD	4D56
V5M21-9-TEG5	G	25/8	L200-4WD	4M40
V5M21-6-GEK	H	25/8	PAJERO/MONTERO	4G64
V5M21-6-GEKL	H	25/8	PAJERO/MONTERO	4G64
V5M21-6-GGK	H	27/8	PAJERO/MONTERO	4G64
V5M21-6-GGKL	H	27/8	PAJERO/MONTERO	4G64
V5M21-6-IEK	H	25/8	PAJERO/MONTERO	4G64
V5M21-6-IEKL	H	25/8	PAJERO/MONTERO	4G64
V5M21-6-IGK	H	27/8	PAJERO/MONTERO	4G64
V5M21-6-IGKL	H	27/8	PAJERO/MONTERO	4G64
V5M21-6-PDA4	H	24/8	PAJERO/MONTERO	4D56
V5M21-6-PDA5	H	24/8	PAJERO/MONTERO	4D56
V5M21-6-PEA4	H	25/8	PAJERO/MONTERO	4D56
V5M21-6-PEA5	H	25/8	PAJERO/MONTERO	4D56
V5M21-6-PFA4	H	26/8	PAJERO/MONTERO	4D56
V5M21-6-PFA5	H	26/8	PAJERO/MONTERO	4D56
V5M21-6-PGA4	H	27/8	PAJERO/MONTERO	4D56
V5M21-6-PGA5	H	27/8	PAJERO/MONTERO	4D56
V5M21-6-RGA4	I	27/8	PAJERO/MONTERO	4M40
V5M21-6-REA4	I	25/8	PAJERO/MONTERO	4M40
V5M21-6-RGA5	I	27/8	PAJERO/MONTERO	4M40
V5M21-6-REA5	I	25/8	PAJERO/MONTERO	4M40
V5M21-7-EJT	I	30/8	L400-4WD	4G63
V5M21-7-EJTL	I	30/8	L400-4WD	4G64
V5M21-7-GGT4	I	27/8	L400-4WD	4G64
V5M21-7-GGT5	I	27/8	L400-4WD	4G64
V5M21-7-QGT4	I	27/8	L400-4WD	4D56
V5M21-A-LJ	K	–	PAJERO-IO	4G18
V5M21-A-HG	K	–	PAJERO-IO	4G93
V5M21-A-LH	K	–	PAJERO-IO	4G93
MMAL R5M21-2-EEA	C	19/5	L300-2WD	4G63
R5M21-2-GDA5	C	20/5	L300-2WD	4G64
R5M21-2-PBC5	D	16/5	L300-2WD	4D56
R5M21-2-QBAP	C	16/5	L300-2WD	4D56
R5M21-5-GF5	D	20/5	L200-2WD	4G64
R5M21-7-EJD	C	30/8	L400-2WD	4G63
R5M21-7-GHD5	C	28/8	L400-2WD	4G64
R5M21-7-GID5	C	29/8	L400-2WD	4G64
V5M21-2-GGA5	I	27/8	L300-4WD	4G64
V5M21-2-QGA5	C	27/8	L300-4WD	4D56
V5M21-7-GGT5	I	27/8	L400-4WD	4G64
V5M21-A-LJ	K	–	PAJERO-IO	4G18
V5M21-A-LH	K	–	PAJERO-IO	4G93

TRANSMISSION MODEL TABLE – MODEL 2000

Transmission Model	Gear ratio	Speedometer gear ratio	Vehicle Model	Engine Model		
EUR	R5M21-2-EECE	C	19/5	L300-2WD	4G63	
	R5M21-2-PACE	C	15/5	L300-2WD	4D56	
	R5M21-2-QACE	C	15/5	L300-2WD	4D56	
	R5M21-5-DIF4	D	29/8	L200-2WD	4G63	
	R5M21-5-PF4	D	26/8	L200-2WD	4D56	
	R5M21-5-PF5	D	26/8	L200-2WD	4D56	
	R5M21-7-EJDL	C	30/8	L400-2WD	4G63	
	R5M21-7-EJL	C	30/8	L400-2WD	4G63	
	R5M21-7-GHD4	C	28/8	L400-2WD	4G64	
	R5M21-7-GID4	C	29/8	L400-2WD	4G64	
	R5M21-7-QF4	C	26/8	L400-2WD	4D56	
	R5M21-8-EEF	C	25/8	L300-2WD (TRUCK)	4G63	
	R5M21-8-QDE	C	24/8	L300-2WD (TRUCK)	4D56	
	V5M21-2-QGCE	J	27/8	L300-4WD	4D56	
	V5M21-7-GGT4	I	27/8	L400-4WD	4G64	
	V5M21-7-QGT4	I	27/8	L400-4WD	4D56	
	V5M21-9-GGG4	I	27/8	L200-4WD	4G64	
	V5M21-9-GEG4	I	27/8	L200-4WD	4G64	
	EXP	R5M21-2-BFAE	D	20/5	L300-2WD	4G92
		R5M21-2-DDAE	D	18/5	L300-2WD	4G63
R5M21-2-DEAE		D	19/5	L300-2WD	4G63	
R5M21-2-EDAE		C	18/5	L300-2WD	4G63	
R5M21-2-EEAE		C	19/5	L300-2WD	4G63	
R5M21-2-PBAE		D	16/5	L300-2WD	4D56	
R5M21-2-QBAE		C	16/5	L300-2WD	4D56	
R5M21-5-PF5		D	26/8	L200-2WD	4D56	
R5M21-5-DI4		D	29/8	L200-2WD	4G63	
R5M21-5-DI5		D	29/8	L200-2WD	4G63	
R5M21-5-DIF4		D	29/8	L200-2WD	4G63	
R5M21-5-PF4		D	26/8	L200-2WD	4D56	
R5M21-5-TF5		D	26/8	L200-2WD	4M40	
R5M21-5-GF4		C	26/8	L200-2WD	4G64	
R5M21-7-EJ		C	30/8	L400-2WD	4G63	
R5M21-7-EJL		C	30/8	L400-2WD	4G63	
R5M21-7-GID		C	29/8	L400-2WD	4G64	
R5M21-7-QF4		C	26/8	L400-2WD	4D56	
V5M21-2-EJA		J	30/8	L300-4WD	4G63	
V5M21-9-DI4		G	29/8	L200-4WD	4G63	
V5M21-9-DI5	G	29/8	L200-4WD	4G63		
V5M21-9-GG4	I	27/8	L200-4WD	4G64		

Transmission Model	Gear ratio	Speedometer gear ratio	Vehicle Model	Engine Model	
EXP	V5M21-9-PG4	G	27/8	L200-4WD	4D56
	V5M21-9-PG5	G	27/8	L200-4WD	4D56
	V5M21-9-TEG5	G	25/8	L200-4WD	4M40
V5M21-6-GEK	H	25/8	PAJERO/MONTERO	4G64	
V5M21-6-GEKL	H	25/8	PAJERO/MONTERO	4G64	
V5M21-6-GGK	H	27/8	PAJERO/MONTERO	4G64	
V5M21-6-GGKL	H	27/8	PAJERO/MONTERO	4G64	
V5M21-6-IEK	H	25/8	PAJERO/MONTERO	4G64	
V5M21-6-IEKL	H	25/8	PAJERO/MONTERO	4G64	
V5M21-6-IGK	H	27/8	PAJERO/MONTERO	4G64	
V5M21-6-IGKL	H	27/8	PAJERO/MONTERO	4G64	
V5M21-6-PDA4	H	24/8	PAJERO/MONTERO	4D56	
V5M21-6-PDA5	H	24/8	PAJERO/MONTERO	4D56	
V5M21-6-PEA4	H	25/8	PAJERO/MONTERO	4D56	
V5M21-6-PEA5	H	25/8	PAJERO/MONTERO	4D56	
V5M21-6-PFA4	H	26/8	PAJERO/MONTERO	4D56	
V5M21-6-PFA5	H	26/8	PAJERO/MONTERO	4D56	
V5M21-6-PGA4	H	27/8	PAJERO/MONTERO	4D56	
V5M21-6-PGA5	H	27/8	PAJERO/MONTERO	4D56	
V5M21-6-RGA4	I	27/8	PAJERO/MONTERO	4M40	
V5M21-6-REA4	I	25/8	PAJERO/MONTERO	4M40	
V5M21-6-RGA5	I	27/8	PAJERO/MONTERO	4M40	
V5M21-6-REA5	I	25/8	PAJERO/MONTERO	4M40	
V5M21-7-EJT	I	30/8	L400-4WD	4G63	
V5M21-7-GGT4	I	27/8	L400-4WD	4G64	
V5M21-7-QGT4	I	27/8	L400-4WD	4D56	
MMAL	R5M21-2-EEAE	C	19/5	L300-2WD	4G63
	R5M21-2-GDAE	C	20/5	L300-2WD	4G64
	R5M21-2-PBCE	D	16/5	L300-2WD	4D56
	R5M21-2-QBAE	C	16/5	L300-2WD	4D56
R5M21-5-GF5	D	20/5	L200-2WD	4G64	
R5M21-5-TF5	D	26/5	L200-2WD	4M40	
R5M21-7-EJD	C	30/8	L400-2WD	4G63	
R5M21-7-GID5	C	29/8	L400-2WD	4G64	
V5M21-2-GGA5	I	27/8	L300-4WD	4G64	
V5M21-2-QGA5	C	27/8	L300-4WD	4D56	
V5M21-7-GGT5	I	27/8	L400-4WD	4G64	
V5M21-9-TF5	GI	25/8	L200-4WD	4M40	

GENERAL SPECIFICATIONS

Gear ratio	A	B	C	D	E	F
1st	4.330	4.021	3.967	4.330	3.369	3.740
2nd	2.355	2.558	2.136	2.355	2.035	2.035
3rd	1.509	1.637	1.360	1.509	1.360	1.360
4th	1.000	1.000	1.000	1.000	1.000	1.000
5th	–	–	0.856	0.827	0.856	0.856
Reverse	4.142	4.142	3.578	4.142	3.578	3.635

Gear ratio	G	H	I	J	K
1st	4.330	4.330	3.967	3.967	3.967
2nd	2.355	2.355	2.136	2.136	2.136
3rd	1.509	1.509	1.360	1.360	1.360
4th	1.000	1.000	1.000	1.000	1.000
5th	0.827	0.827	0.856	0.856	0.822
Reverse	4.142	4.142	3.578	3.578	3.578
High	1.000	1.000	1.000	1.000	1.000
Low	1.925	1.944	1.925	1.944	1.548

COMPARISON BETWEEN OLD AND NEW TRANSMISSION MODELS

Vehicle Model	Engine Model	Transmission Model	
		Old	New
PAJERO/MONTERO	4D56	KM145-7, KM145-A	V5M21-4-P
	4G54, 4D56 turbocharger	KM145-9, KM145-B	V5M21-4-Q
	4G64	–	V5M21-5-G
	4G54	–	V5M21-5-Q
	4D56	–	V5M21-5-P
L200-2WD	4G32	KM130-6	R4M21-1-B
	4G63	KM132-H	R5M21-1-D
	4G54	KM132-I	R5M21-1-J
	4D56	KM132-J	R5M21-1-P
	4G63	KM132-K	–
	4G32	KM132-L	R5M21-1-B
	4G64	–	R5M21-1-G
L200-4WD	4G63	KM145-6, KM145-C	V5M21-1-D
	4D56	KM145-7, KM145-A	V5M21-1-P
	4G54, 4G64	KM145-8, KM145-D	V5M21-1-G, V5M21-1-J
L300-2WD	4G32	KM131-3	R4M21-2-B
	4G33	KM131-4	R4M21-2-A
	4G32	KM135-5	R5M21-2-B
	4D56	KM135-8	R5M21-2-P
	4G32, 4G63	KM135-9	R5M21-2-C, R5M21-2-E
	4G64, 4D56, 4D56 turbocharger	KM135-B	R5M21-2-G, R5M21-2-Q
	L300-2WD (TRUCK)	4D56	KM135-8-T
L300-4WD	4G63	KM147-3, KM147-6	V5M21-2-E
	4G64, 4D56, 4D56 turbocharger	KM147-5, KM147-7	V5M21-2-G, V5M21-2-Q
STARION	4G54 Intercooler turbocharger	KM132-M, KM132-N	R5M21-4-K

SERVICE SPECIFICATIONS

mm (in.)

Items	Standard	Remarks
Transmission		
Main drive gear bearing end play	0 – 0.06 (0 – 0.0024)	Adjust with snap ring
Front bearing retainer to bearing clearance	0 – 0.1 (0 – 0.004)	Adjust with spacer
3rd-4th speed synchronizer hub end play	0 – 0.08 (0 – 0.0031)	Adjust with snap ring
Main shaft rear bearing end play	0 – 0.13 (0 – 0.0051)	Adjust with snap ring
Counter reverse gear end play	0 – 0.07 (0 – 0.0027)	Adjust with snap ring
Countershaft preload	0 – 0.05 (0 – 0.0020)	Adjust with spacer
Overdrive gear end play	0.15 – 0.40 (0.0059 – 0.0157)	Adjust with snap ring
Overdrive gear sleeve end play	0 – 0.2 (0 – 0.008)	Adjust with snap ring
Select shaft snap ring	0.1 – 0.4 (0.004 – 0.016)	Adjust with snap ring
Shift shaft snap ring		
Control rink side	0.1 – 0.4 (0.004 – 0.016)	Adjust with snap ring
Spacer side	0.1 – 0.45 (0.004 – 0.0177)	Adjust with snap ring
Transfer (KM145, KM147, V5M21)		
Input gear end play	0 – 0.06 (0 – 0.0024)	Adjust with snap ring
Input gear bearing end play	0 – 0.06 (0 – 0.0024)	Adjust with snap ring
H-L clutch hub end play	0 – 0.08 (0 – 0.0031)	Adjust with snap ring
Rear output shaft end play	0 – 0.1 (0 – 0.004)	Adjust with spacer
Front output shaft end play	2 (0.08) or less	Adjust with spacer
2-4WD clutch hub end play	0 – 0.08 (0 – 0.0031)	Adjust with snap ring
Differential lock hub end play	0 – 0.08 (0 – 0.0031)	Adjust with snap ring
Rear output shaft rear bearing end play	0 – 0.08 (0 – 0.0031)	Adjust with snap ring

TORQUE SPECIFICATIONS

	Torque		
	Nm	kgm	ft.lbs.
Transmission			
Backup lamp switch	30	3.0	22
Countershaft lock nut	160 – 190	16 – 19	116 – 137
Extension housing mounting bolt	15 – 22	1.5 – 2.2	11 – 15
Extension housing cover mounting bolt	15 – 22	1.5 – 2.2	11 – 15
Front bearing retainer mounting nut	10 – 13	1.0 – 1.3	7.5 – 9.0
Oil drain plug			
(KM132-M, N, R5M21-4-K)	35 – 45	3.5 – 4.5	26 – 32
(Except KM132-M, N, R5M21-4-K, KM145, KM147, V5M21)	30 – 35	3.0 – 3.5	22 – 25
(KM145, KM147, V5M21)	60	6.0	44
Oil filler plug	30 – 35	3.0 – 3.5	22 – 25
Main shaft lock nut			
(KM130, KM131, R4M21)	100 – 130	10 – 13	73 – 94
(KM132, KM135, KM145, KM147, R5M21, V5M21)	250 – 270	25 – 27	181 – 195
Rear bearing retainer mounting bolt	15 – 22	1.5 – 2.2	11 – 15
Reverse idler gear shaft lock nut	20 – 60	2.0 – 6.0	15 – 43
Reverse idler gear shaft mounting bolt	15 – 22	1.5 – 2.2	11 – 15
Seal plug	30 – 42	3.0 – 4.2	22 – 30
Select adjuster nut	30 – 42	3.0 – 4.2	22 – 30
Speedometer sleeve clamp bolt	10 – 13	1.0 – 1.3	7.5 – 9.0
Stopper bracket mounting nut	15 – 22	1.5 – 2.2	11 – 15
Transmission case to adapter bolt	15 – 22	1.5 – 2.2	11 – 15
Under cover bolt			
(KM132-M, N, R5M21-4-K)	15 – 22	1.5 – 2.2	11 – 15
(Except KM132-M, N, R5M21-4-K)	8 – 10	0.8 – 1.0	6 – 7

	Torque		
	Nm	kgm	ft.lbs.
Transfer (KM145, KM147, V5M21 except V5M21-A)			
Adapter to transfer case mounting bolt	30 – 42	3.0 – 4.2	22 – 30
Chain cover bolt	30 – 42	3.0 – 4.2	22 – 30
Cover bolt	15 – 22	1.5 – 2.2	11 – 15
Lock plate bolt	15 – 22	1.5 – 2.2	11 – 15
Oil drain plug	30 – 35	3.0 – 3.5	22 – 25
Oil filler plug	30 – 35	3.0 – 3.5	22 – 25
Pulse generator mounting bolt	10 – 13	1.0 – 1.3	7.5 – 9.0
Pulse rotor mounting bolt	15 – 22	1.5 – 2.2	11 – 15
Rear cover bolt	15 – 22	1.5 – 2.2	11 – 15
Rear output shaft lock nut	100 – 130	10 – 13	73 – 94
Select plunger plug	30 – 35	3.0 – 3.5	22 – 25
Side cover bolt	8 – 10	0.8 – 1.0	6 – 7
Speedometer sleeve clamp bolt	15 – 22	1.5 – 2.2	11 – 15
4WD indicator light switch	30	3.0	22
Seal plug	36	3.6	26
Detection switch	36	3.6	26
Poppet plug	36	3.6	26
H-L shift rail plug	33	3.3	24
Plunger boss bolt	33	3.3	24
Transfer (V5M21-A)			
Transfer case plate to transfer case mounting bolt	35	3.6	26
Transfer case to transfer rear cover mounting bolt	35	3.6	26
Center bearing retainer mounting seal bolt	18	1.9	14
Interlock plunger seal bolt	35	3.6	26
Vehicle speed sensor mounting bolt	11	1.1	8
Transfer control housing mounting bolt	18	1.9	14
Select plunger seal bolt	32	3.3	24
Poppet seal bolt	35	3.6	26
Detector switches	34	3.5	25
Control Lever Assembly			
Control housing assembly bolt	15 – 22	1.5 – 2.2	11 – 15
Control housing cover bolt	15 – 22	1.5 – 2.2	11 – 15
Control lever assembly bolt	15 – 22	1.5 – 2.2	11 – 15
Control lever bolt	7 – 11	0.7 – 1.1	5 – 7.5
Select shaft lever nut	30 – 35	3.0 – 3.5	22 – 25
Shift lever set screw	8 – 10	0.8 – 1.0	6 – 7

SEALANTS, ADHESIVES AND GREASE

Items	Specified sealants, adhesives and grease
Transmission	
Adapter gasket	Mitsubishi genuine sealant Part No. 997740 or equivalent
Air breather	3M Super Weatherstrip No. 8001 or equivalent
Case gasket	Mitsubishi genuine sealant Part No. 997740 or equivalent
Front bearing retainer gasket	Mitsubishi genuine sealant Part No. 997740 or equivalent
Front bearing retainer oil seal	Mitsubishi genuine grease Part No. 0101011 or equivalent
Poppet plug	3M ATD Part No. 8660 or equivalent
Rear bearing retainer mounting bolt	3M STUD Locking No. 4170 or equivalent
Reverse idler gear shaft mounting bolt	3M STUD Locking No. 4170 or equivalent
Neutral plunger	Mitsubishi genuine grease Part No. 0101011 or equivalent
Seal plug	3M ATD Part No. 8660 or equivalent
Friction damper	Mitsubishi genuine grease Part No. 0101011 or equivalent
Splines in transmission main shaft and transfer input gear	Mitsubishi genuine grease Part No. 0101011 or equivalent
Transfer (KM145, KM147, V5M21)	
Air breather	3M Super Weatherstrip No. 8001 or equivalent
Chain cover gasket	Mitsubishi genuine sealant Part No. 997740 or equivalent
Cover gasket	Mitsubishi genuine sealant Part No. 997740 or equivalent
Cover mounting bolt	3M STUD Locking No. 4170 or equivalent
Rear cover gasket	Mitsubishi genuine sealant Part No. 997740 or equivalent
Chain cover	Mitsubishi genuine sealant Part No. 997740 or equivalent
Poppet plug	3M ATD Part No. 8660 or equivalent
Plug	3M ATD Part No. 8660 or equivalent
Return spring plug	3M Super Weatherstrip No. 8001 or equivalent
Cover	Mitsubishi genuine sealant Part No. 997740 or equivalent
Rear cover	Mitsubishi genuine sealant Part No. 997740 or equivalent
Control Lever Assembly	
Control lever gasket	Mitsubishi genuine sealant Part No. 997740 or equivalent
Stopper bracket assembly mounting bolt – special bolt	
Threaded part	3M Scotch Grip No. 2353 or equivalent
Seat	3M ATD Part No. 8660 or equivalent
Stopper plate gasket	Mitsubishi genuine sealant Part No. 997740 or equivalent
Transfer control lever housing cover gasket	Mitsubishi genuine sealant Part No. 997740 or equivalent
Extension housing assembly (R5M21-7)	
Stopper bracket assembly mounting bolt – special bolt	
Threaded part	3M ATD Part No. 2353 or equivalent
Seat	3M ATD Part No. 8660 or equivalent
Control shaft cap	3M ATD Part No. 8660 or equivalent

ADJUSTMENT SNAP RINGS AND SPACERS





Part name	Thickness mm (in.)	Identification symbol	Part No.
Transmission			
Spacer: Except KM132-M, N, R5M21-4-K (For adjustment of front bearing retainer)	0.84 (0.0331)	Black	MD701845
	0.93 (0.0366)	–	MD701839
	1.02 (0.0402)	Red	MD701840
	1.11 (0.0437)	White	MD701841
	1.20 (0.0472)	Yellow	MD701842
	1.29 (0.0508)	Blue	MD701843
	1.38 (0.0543)	Green	MD701844
Spacer: KM132-M, N, R5M21-4-K (For adjustment of front bearing retainer)	0.84 (0.0331)	Black	MD725212
	0.93 (0.0366)	–	MD725213
	1.02 (0.0402)	Red	MD725214
	1.11 (0.0437)	White	MD725215
	1.20 (0.0472)	Yellow	MD725216
Snap ring (For adjustment of main drive gear bearing)	2.30 (0.0906)	White	MD701729
	2.35 (0.0925)	Brown	MD701730
	2.40 (0.0945)	–	MD701731
	2.45 (0.0965)	Blue	MD701732
	2.50 (0.0984)	Yellow	MD701733
Snap ring (For adjustment of 3rd-4th speed synchronizer hub)	2.15 (0.0846)	Blue	MD701761
	2.22 (0.0874)	–	MD701762
	2.29 (0.0902)	Brown	MD701763
	2.36 (0.0929)	White	MD701764
Snap ring: Except KM132-M, N, R5M21-4-K (For adjustment of main shaft overdrive gear)	2.60 (0.1024)	White	MD723092
	2.79 (0.1098)	Blue	MD723093
	2.98 (0.1173)	–	MD723094
	3.17 (0.1248)	Black	MD723095
	3.36 (0.1323)	Red	MD723096
	3.55 (0.1398)	Yellow	MD723099
Snap ring (For adjustment of countershaft reverse gear)	1.70 (0.0669)	–	MD705843
	1.80 (0.0709)	Blue	MD705857
	1.90 (0.0748)	Green	MD705858
	2.00 (0.0787)	Brown	MD705845

Part name	Thickness mm (in.)	Identification symbol	Part No.
Spacer (For adjustment of countershaft)	1.84 (0.0724)	84	MD706580
	1.87 (0.0736)	87	MD706581
	1.90 (0.0748)	90	MD706582
	1.93 (0.0760)	93	MD706583
	1.96 (0.0772)	96	MD706584
	1.99 (0.0783)	99	MD706585
	2.02 (0.0795)	02	MD706586
	2.05 (0.0807)	05	MD706587
	2.08 (0.0819)	08	MD706588
	2.11 (0.0831)	11	MD706589
	2.14 (0.0843)	14	MD706590
	2.17 (0.0854)	17	MD706591
	2.20 (0.0866)	20	MD706592
	2.23 (0.0878)	23	MD706593
	2.26 (0.0890)	26	MD706594
	2.29 (0.0902)	29	MD706595
	2.32 (0.0913)	32	MD706596
	2.35 (0.0925)	35	MD706597
	2.38 (0.0937)	38	MD706598
	Snap ring: KM132-M, N, R5M21-4-K (For adjustment of main shaft overdrive gear sleeve)	2.41 (0.0949)	41
2.44 (0.0961)		44	MD706600
2.47 (0.0972)		47	MD706601
2.50 (0.0984)		50	MD706602
2.53 (0.0996)		53	MD706603
2.56 (0.1008)		56	MD706604
2.59 (0.1020)		59	MD706605
2.17 (0.0854)		White	MD729179
2.36 (0.0929)		Blue	MD729180
2.53 (0.0996)		Black	MD729181
2.74 (0.1079)		–	MD729182
2.93 (0.1154)		Brown	MD729183
3.12 (0.1228)	Red	MD729184	
3.31 (0.1303)	Yellow	MD729185	
3.50 (0.1378)	White	MD729186	
3.69 (0.1453)	Blue	MD729187	
Snap ring (For adjustment of select shaft and shift shaft)	1.2 (0.047)	White	MD724540
	1.4 (0.055)	Blue	MD724541
	1.6 (0.063)	–	MD724542
	1.8 (0.071)	Brown	MD724543
	2.0 (0.079)	Red	MD724544
Snap ring (For adjustment of main shaft bearing)	1.4 (0.055)	–	MD703779
	1.5 (0.059)	Brown	MD703780

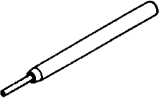
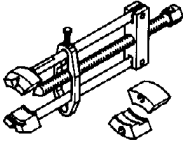
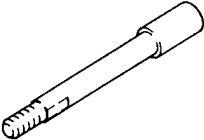
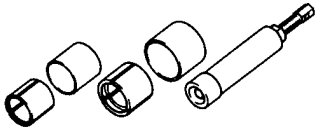
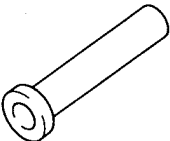
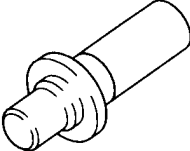
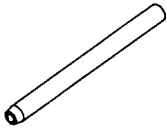
Part name	Thickness mm (in.)	Identification symbol	Part No.
Transfer (KM145, KM147, V5M21)			
Snap ring (For adjustment of input gear bearing)	2.30 (0.0906)	–	MD704199
	2.35 (0.0925)	Red	MD704200
	2.40 (0.0945)	White	MD704201
	2.45 (0.0965)	Blue	MD704202
	2.50 (0.0984)	Green	MD704203
Snap ring (For adjustment of input gear assembly)	2.70 (0.1063)	Purple	MD704204
	2.75 (0.1083)	Pink	MD704205
	2.80 (0.1102)	Yellow	MD704206
	2.85 (0.1122)	White	MD704207
	2.90 (0.1142)	Blue	MD704208
Snap ring (For adjustment of H-L clutch hub)	2.14 (0.0843)	–	MD704212
	2.21 (0.0870)	Yellow	MD704213
	2.28 (0.0898)	White	MD704214
	2.35 (0.0925)	Blue	MD704215
	2.42 (0.0953)	Red	MD704216
Spacer (For adjustment of rear output shaft)	0.84 (0.0331)	Black	MD701845
	0.93 (0.0366)	–	MD701839
	1.02 (0.0402)	Red	MD701840
	1.11 (0.0437)	White	MD701841
	1.20 (0.0472)	Yellow	MD701842
	1.29 (0.0508)	Blue	MD701843
Snap ring (For adjustment of differential lock hub)	1.38 (0.0543)	Green	MD701844
	2.56 (0.1008)	–	MD738386
	2.63 (0.1035)	Red	MD738387
	2.70 (0.1063)	White	MD738388
	2.77 (0.1091)	Blue	MD738389
	2.84 (0.1118)	Yellow	MD738390
	2.91 (0.1146)	Green	MD738391
2.98 (0.1173)	Purple	MD738392	
Snap ring (For adjustment of rear output shaft bearing)	2.18 (0.0858)	Blue	MR388669
	2.25 (0.0886)	–	MR388670
	2.32 (0.0913)	Brown	MR388671
	2.39 (0.0941)	White	MR388672
Snap ring (For adjustment of 2-4WD clutch hub)	2.56 (0.1008)	–	MD738393
	2.63 (0.1035)	Red	MD738394
	2.70 (0.1063)	White	MD738395
	2.77 (0.1091)	Blue	MD738396
	2.84 (0.1118)	Yellow	MD738397

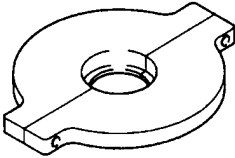
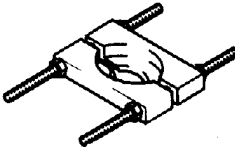

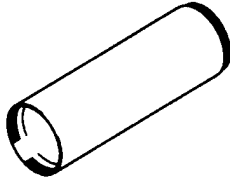

2. SPECIAL TOOLS

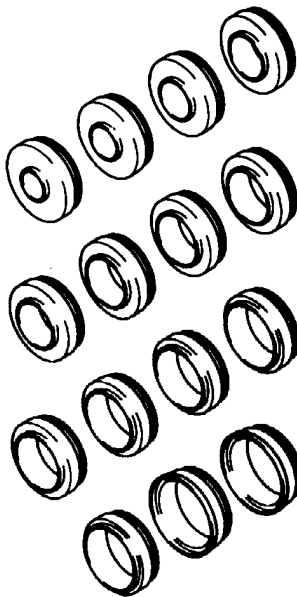
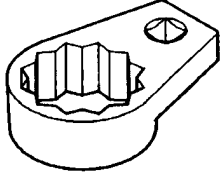
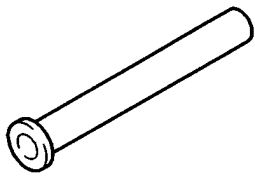
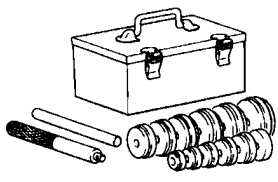
Tool	Number	Name	Use
	MD998019	Lock pin extractor	Driving out of the spring pin and lock pin
	MD998020	Bearing puller	Removal of the bearing and bearing sleeve
	MD998028	Bearing puller adapter	Use with MD998020
	MD998192	Counter gear bearing puller	Removal of the countershaft front bearing and center bearing
	MD998199	Countershaft bearing installer	Installation of the countershaft front bearing
	MD998200	Front bearing retainer oil seal installer	Installation of front bearing retainer oil seal
	MD998245	Lock pin installer	Driving in of the spring pin and lock pin

Tool	Number	Name	Use
	MD998359	Taper bearing puller	Removal of the countershaft bearing
	MD998801	Bearing puller	Removal and installation of the clutch hub and bearing
	MD998809	Lock nut wrench (41)	Removal of the mainshaft lock nut
	MD998812	Installer cap	Installation of the bearing
	MD998813	Installer (100)	Installation of the bearing
	MD998814	Installer (200)	Installation of the bearing

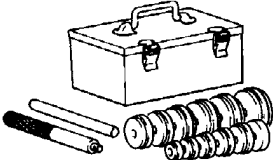
Tool	Number	Name	Use
	MD998815 MD998816 MD998817 MD998818 MD998819 MD998820 MD998821 MD998822 MD998823 MD998824 MD998825 MD998826 MD998827 MD998829 MD998830	Installer adapter	Installation of the bearing
	MD998835	Lock nut wrench (46)	Removal of the transfer rear output shaft lock nut
	MD998067	Bearing installer	Installation of the bearing
	MB990925	Bearing and oil seal installer set	Installation of the oil seal

CONTENTS OF BEARING AND OIL SEAL INSTALLER SET MB990925

Set	Contents			
	Tool	Name	Tool No.	Diameter mm (in.)
Bearing and oil seal installer set MB990925 		Installer adapter	MB990926	39 (1.535)
			MB990927	45 (1.772)
			MB990928	49.5 (1.949)
			MB990929	51 (2.008)
			MB990930	54 (2.126)
			MB990931	57 (2.244)
			MB990932	61 (2.402)
			MB990933	63.5 (2.500)
			MB990934	67.5 (2.657)
			MB990935	71.5 (2.815)
			MB990936	75.5 (2.972)
			MB990937	79 (3.110)
				
		Brass bar	MB990939	–

3. TRANSMISSION

R4M21-1 (KM130-6)

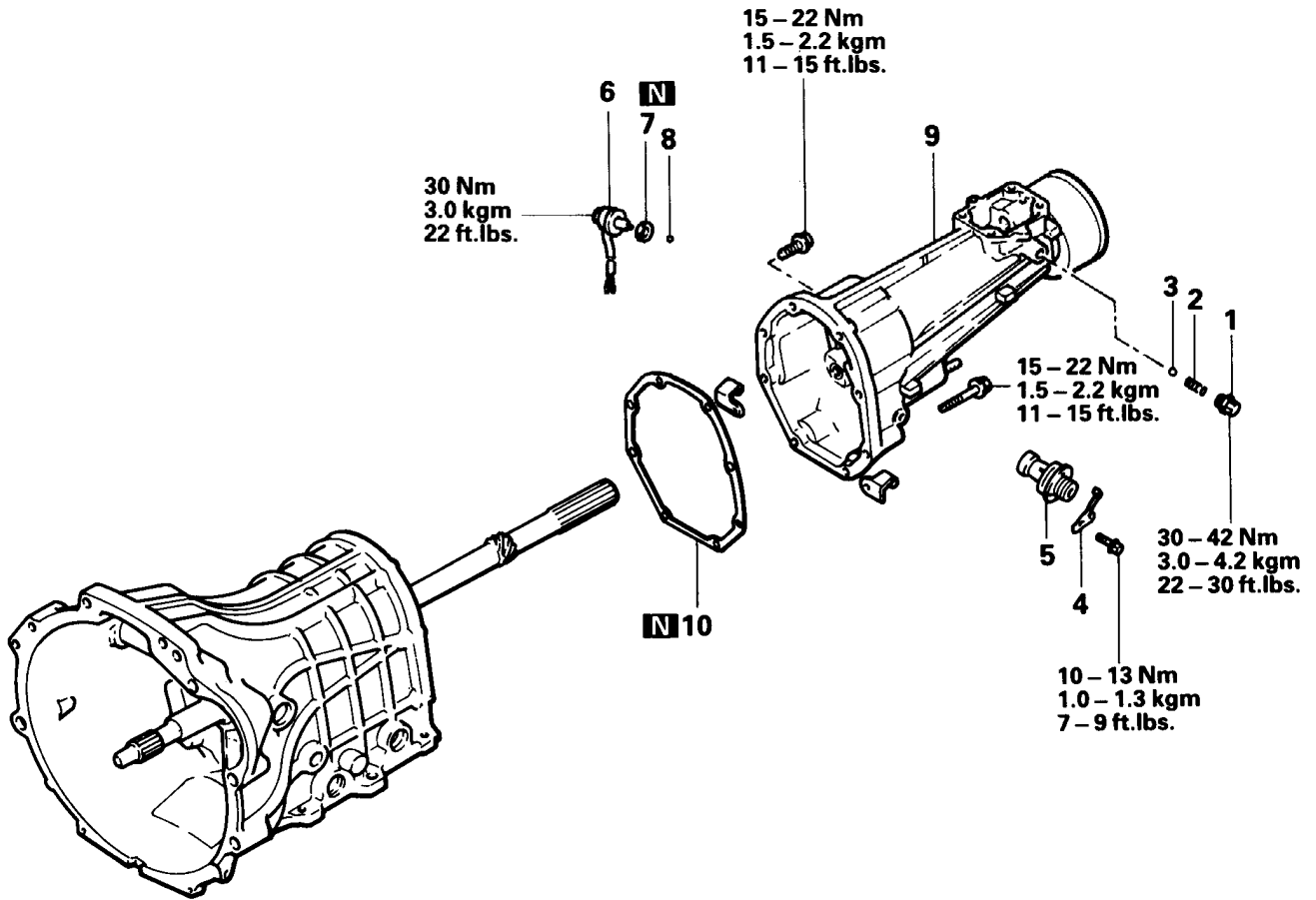

Disassembly steps

- 1. Seal plug
- 2. Resistance spring
- 3. Steel ball
- 4. Sleeve clamp
- g 5. Speedometer gear
- 6. Backup lamp switch
- 7. Gasket
- 8. Steel ball
- B i 9. Extension housing
- h 10. Extension housing gasket

R4M21-1 (KM130-6)

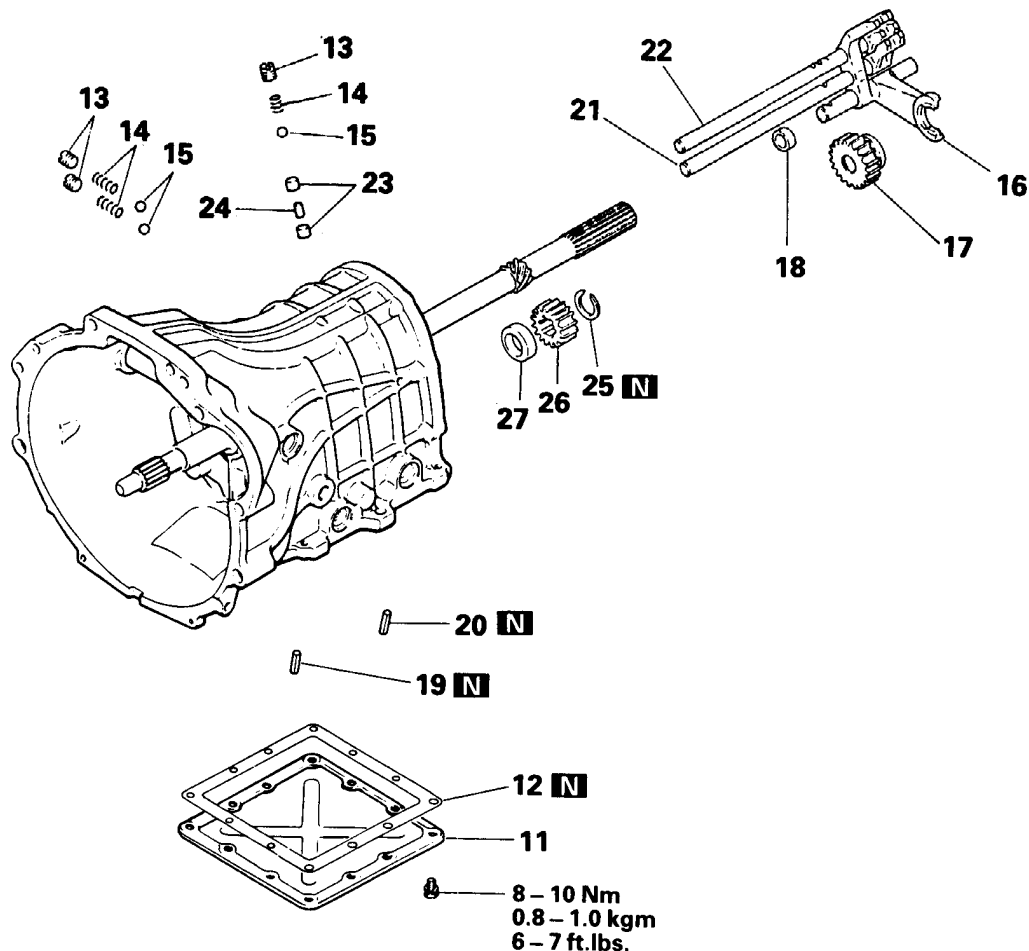

Disassembly steps

- 11. Under cover
- 12. Under cover gasket
- 13. Poppet plug
- b** 14. Poppet spring
- b** 15. Steel ball
- 16. Reverse shift fork and rail
- 17. Reverse idler gear
- 18. Distance piece
- C** **Y** 19. Spring pin for 3rd – 4th speed shift fork
- C** **Y** 20. Spring pin for 1st – 2nd speed shift fork
- 21. 1st – 2nd speed shift rail
- 22. 3rd – 4th speed shift rail
- 23. Interlock plunger
- 24. Interlock plunger B
- 25. Snap ring
- 26. Counter reverse gear
- 27. Spacer

R4M21-1 (KM130-6)

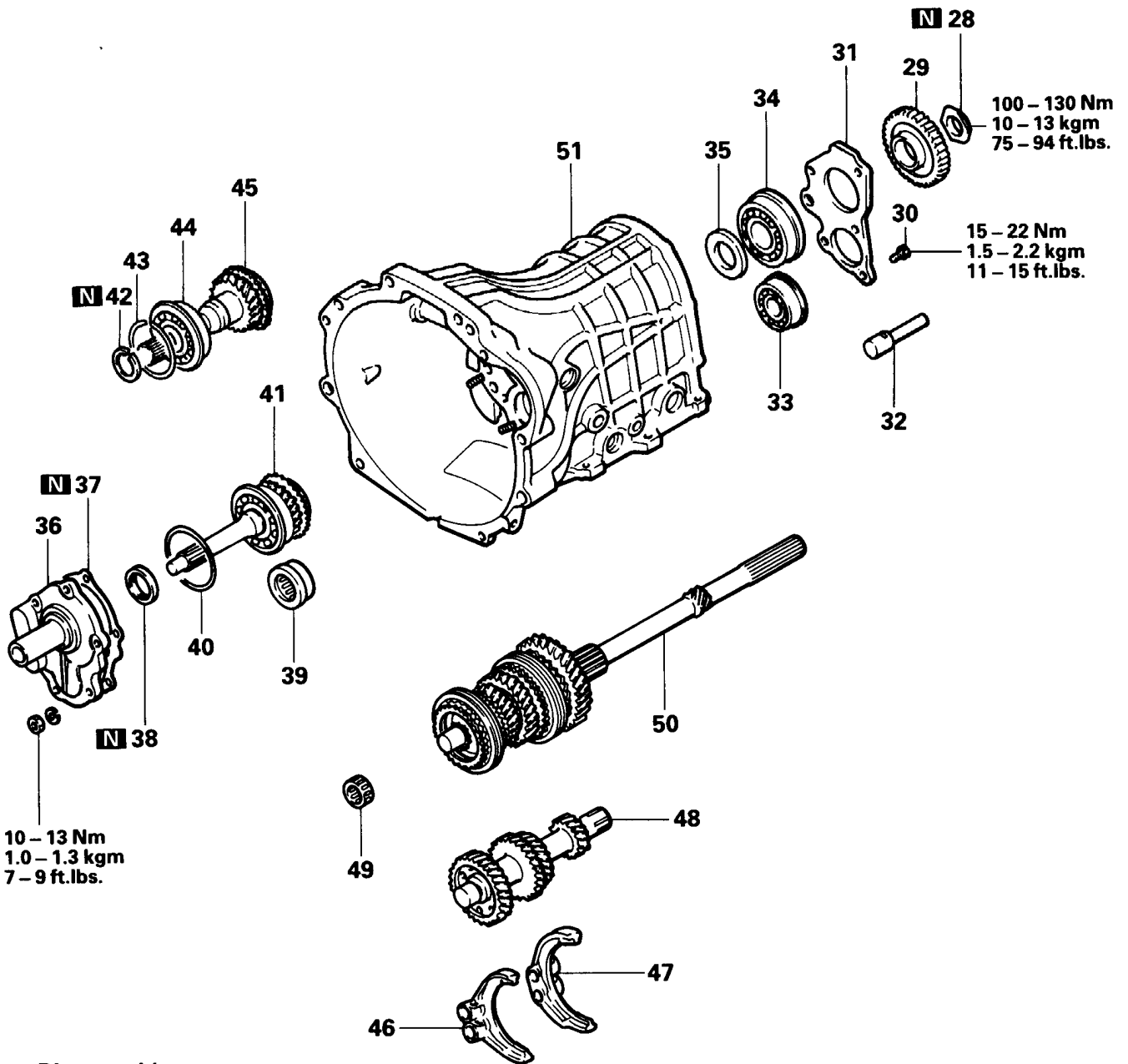

Disassembly steps

- | | | | |
|-----|-----|--|-------------|
| (E) | (S) | 28. Mainshaft lock nut | |
| | | 29. Reverse gear | |
| | (K) | 30. Bolt | |
| | | 31. Rear bearing retainer | |
| | | 32. Reverse idler gear shaft | |
| (H) | (I) | 33. Countershaft rear bearing | |
| | | 34. Mainshaft rear bearing | |
| | | 35. Bearing spacer | |
| | | 36. Front bearing retainer | |
| | (G) | 37. Front bearing retainer gasket | |
| | (J) | 38. Oil seal | |
| | (D) | 39. Countershaft front bearing | |
| | (F) | 40. Spacer | |
| | | 41. Maindrive gear assembly – Up to 1989 | |
| | (C) | 42. Snap ring | } From 1990 |
| | | 43. Snap ring | |
| (K) | (B) | 44. Maindrive gear bearing | |
| | | 45. Maindrive gear | |
| | | 46. 3rd – 4th speed shift fork | |
| | | 47. 1st – 2nd speed shift fork | |
| | | 48. Countershaft | |
| | | 49. Mainshaft front bearing | |
| | | 50. Mainshaft assembly | |
| | | 51. Transmission case | |

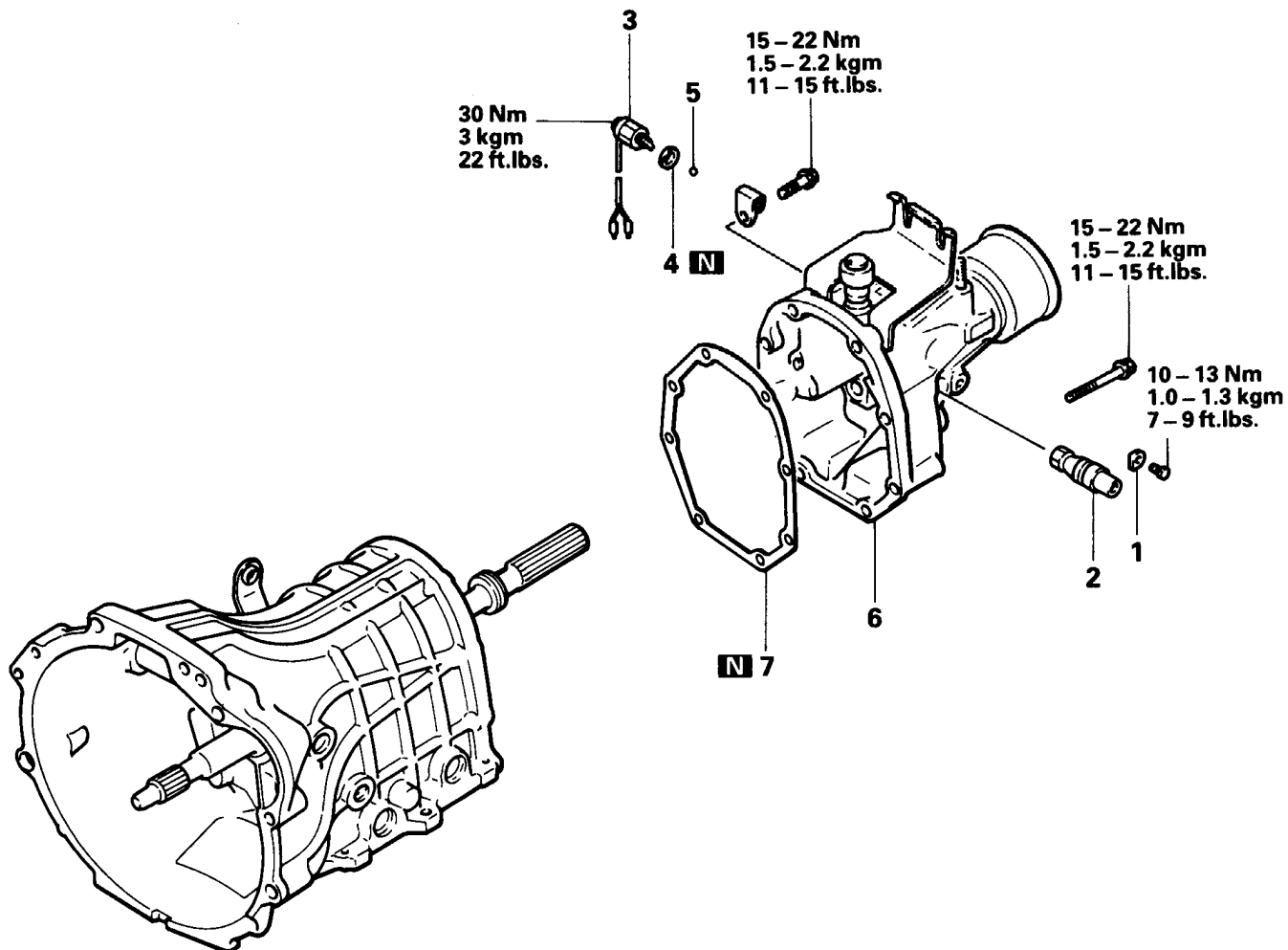
R4M21-2 (KM131)**Disassembly steps**

1. Lock plate
- f** 2. Speedometer gear
3. Backup lamp switch
4. Gasket
5. Steel ball
6. Extension housing
- h** 7. Extension housing gasket

R4M21-2 (KM131)

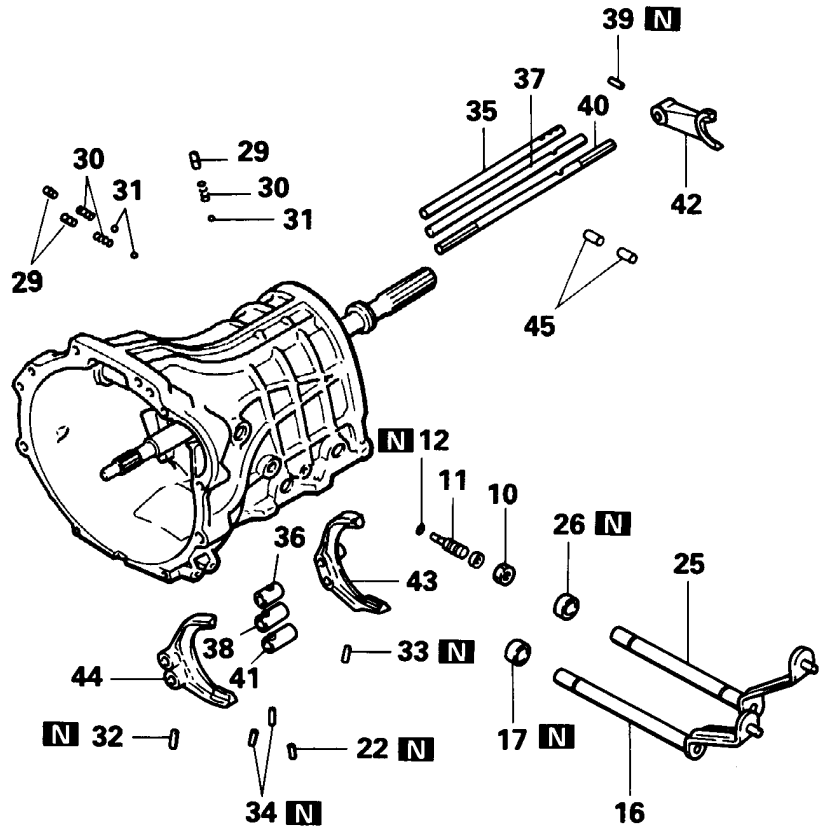

Disassembly steps

- 8. Under cover
- 9. Under cover gasket
- 10. Nut
- W** 11. Select adjuster
- M** **e** 12. O-ring
- N** **d** 13. Spring pin
- N** **d** 14. Snap ring
- N** **d** 15. Spring pin
- 16. Select shaft
- 17. Oil seal
- 18. Adjust arm
- 19. Distance spring
- 20. Return spring
- 21. Spacer
- O** **b** 22. Spring pin for reverse shift lug
- P** **c** **H** **b** 23. Snap ring
- P** **c** **H** **b** 24. Look pin
- 25. Shift shaft
- 26. Oil seal
- 27. Control rink
- 28. Spacer
- 29. Poppet plug
- b** 30. Poppet spring
- b** 31. Steel ball
- O** **c** **H** **b** 32. Spring pin for 3rd-4th speed shift fork
- O** **c** **H** **b** 33. Spring pin for 1st-2nd speed shift fork
- O** **c** **H** **b** 34. Spring pin for 3rd-4th speed shift lug and 1st-2nd speed shift lug
- 35. 1st-2nd speed shift rail
- 36. 1st-2nd speed shift lug
- 37. 3rd-4th speed shift rail
- 38. 3rd-4th speed shift lug
- D** **X** 39. Spring pin for reverse shift fork
- 40. Reverse shift rail
- 41. Reverse shift lug
- 42. Reverse shift fork
- 43. 1st-2nd speed shift fork
- 44. 3rd-4th seed shift fork
- 45. Interlock plunger

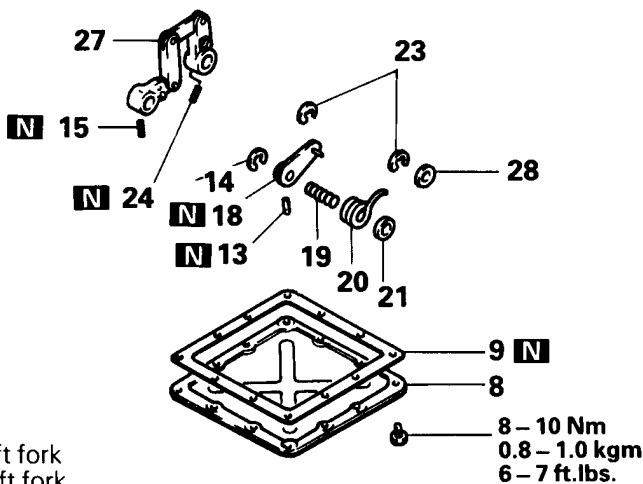

8 – 10 Nm
0.8 – 1.0 kgm
6 – 7 ft.lbs.

R4M21-2 (KM131)

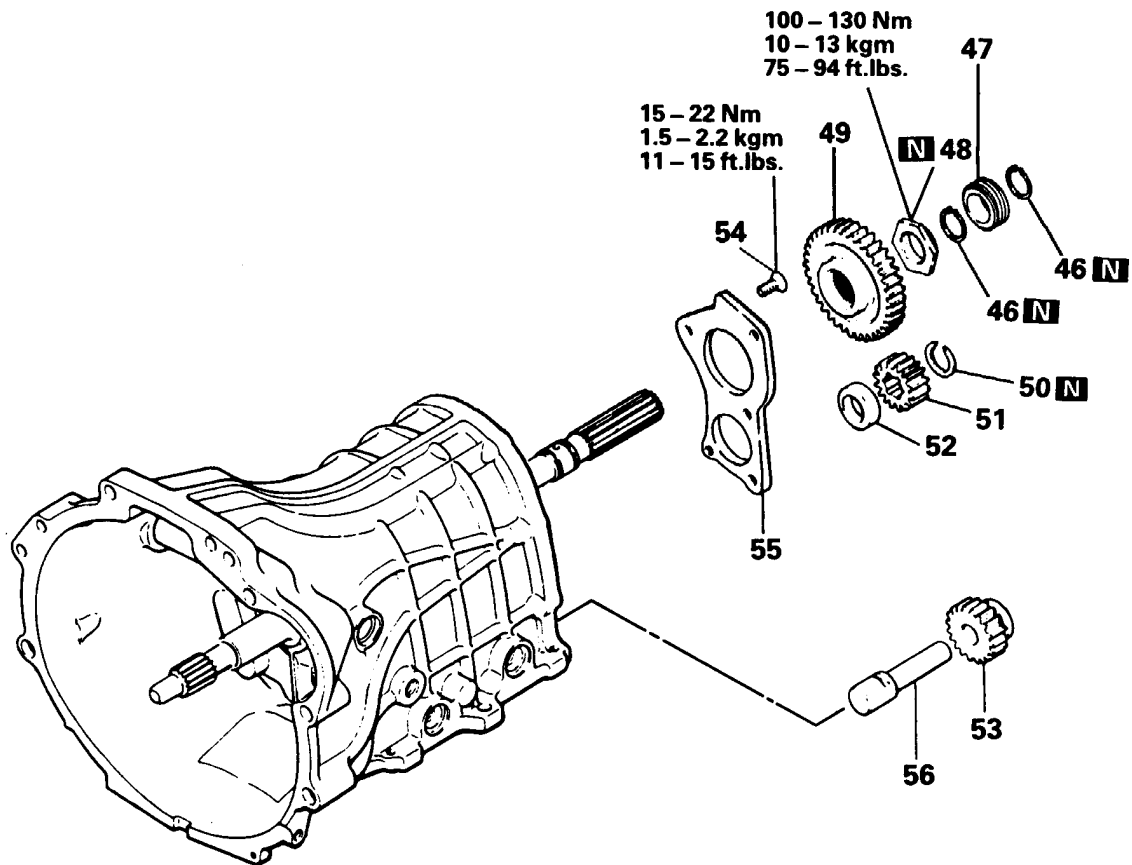
**Disassembly steps**

- 46. Snap ring
- 47. Speedometer drive gear
- (E) (S) 48. Mainshaft lock nut
- 49. Reverse gear
- 50. Snap ring
- 51. Counter reverse gear
- 52. Spacer
- 53. Reverse idler gear
- (K) 54. Bolt
- 55. Rear bearing retainer
- 56. Reverse idler gear shaft

R4M21-2 (KM131)

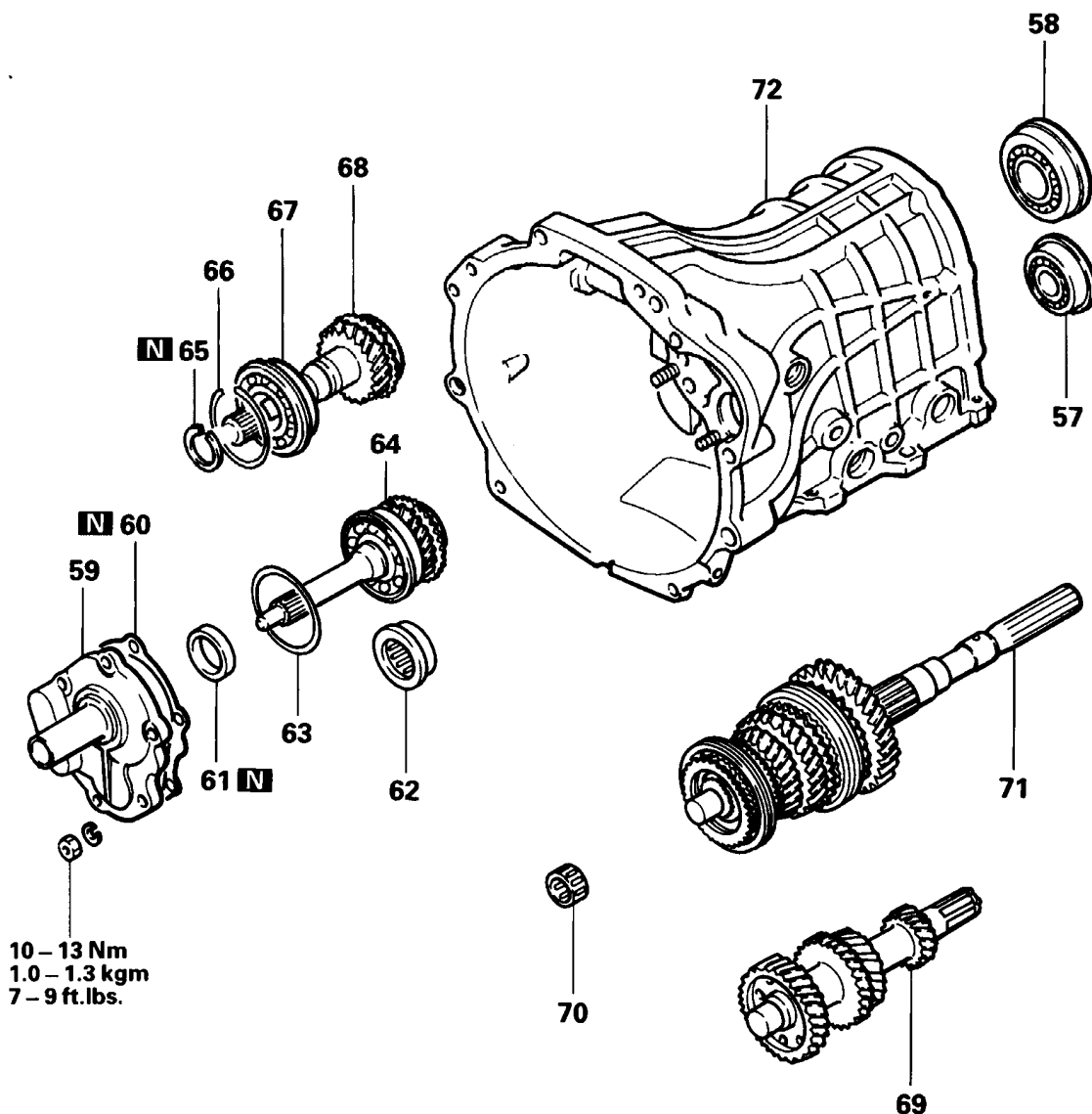

Disassembly steps

- Ⓜ **I** 57. Countershaft rear bearing
- Ⓜ **H** 58. Mainshaft rear bearing
- Ⓜ 59. Front bearing retainer
- G** 60. Front bearing retainer gasket
- E** 61. Oil seal
- Ⓜ **D** 62. Countershaft front bearing
- F** 63. Spacer
- C** 64. Main drive gear assembly – Up to 1989
- C** 65. Snap ring
- C** 66. Snap ring
- Ⓜ **B** 67. Maindrive gear bearing } From 1990
- Ⓜ 68. Maindriver gear
- Ⓜ 69. Countershaft
- Ⓜ 70. Mainshaft front bearing
- Ⓜ 71. Mainshaft assembly
- Ⓜ 72. Transmission case

R5M21-1-B (KM132-L)

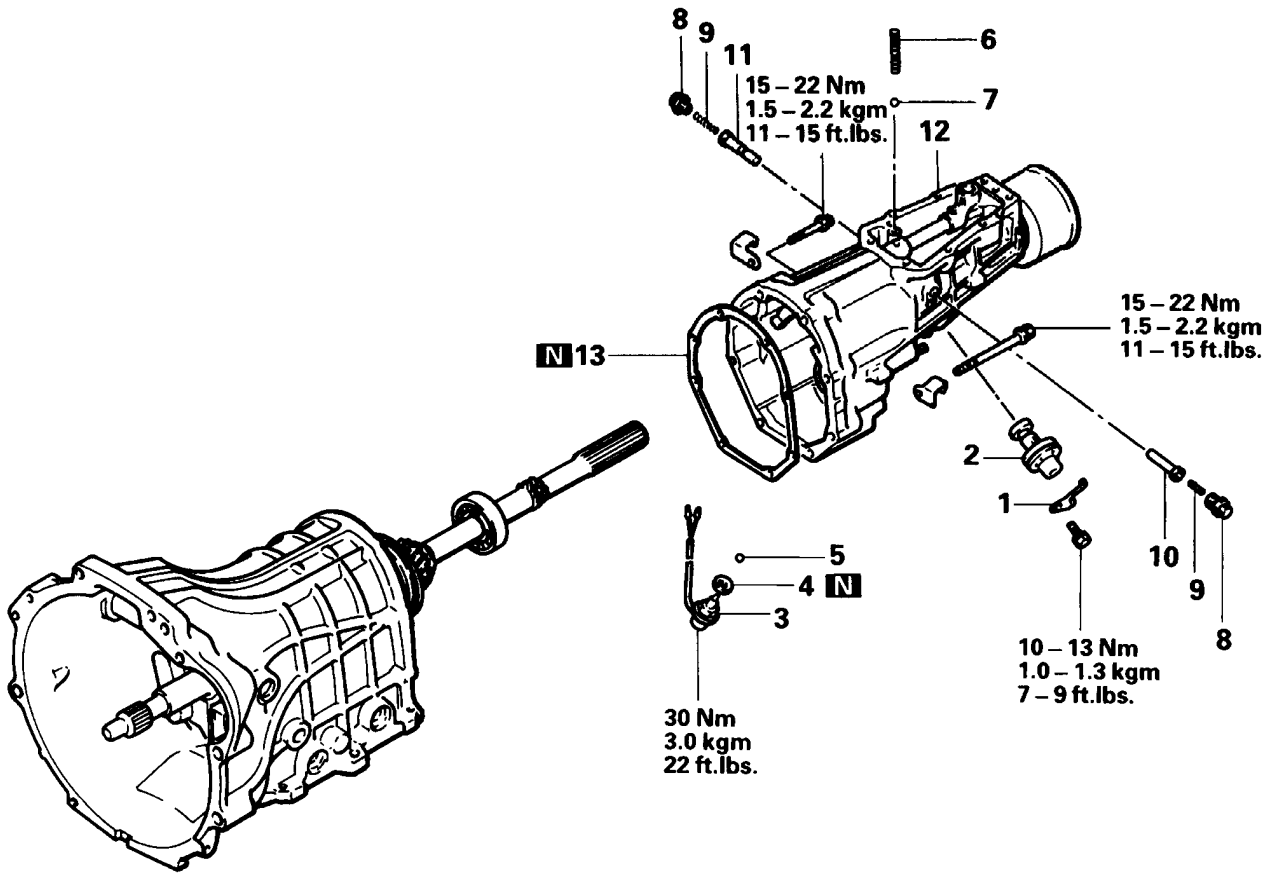

Disassembly steps

- 1. Sleeve clamp
- g** 2. Speedometer gear
- 3. Backup lamp switch
- 4. Gasket
- 5. Steel ball
- 6. Resistance spring
- 7. Steel ball
- r** 8. Seal plug
- 9. Spring
- q** 10. Neutral plunger A
- q** 11. Neutral plunger B
- B** **i** 12. Extension housing
- h** 13. Extension housing gasket

R5M21-1-B (KM132-L)

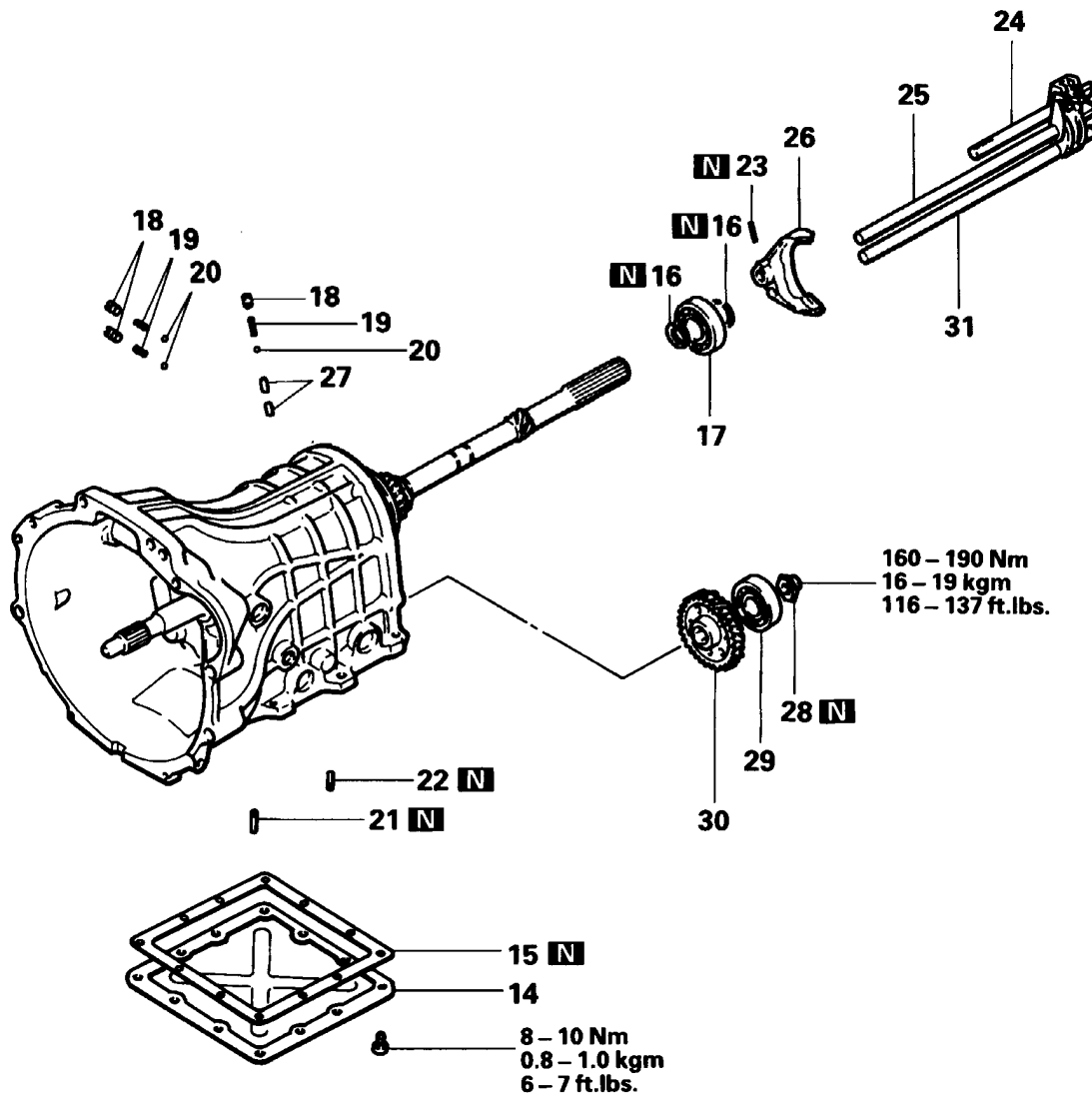

Disassembly steps

- 14. Under cover
- 15. Under cover gasket
- P** 16. Snap ring
- P** 17. Mainshaft rear bearing
- 18. Poppet plug
- b** 19. Poppet spring
- b** 20. Steel ball
- ©** **Y** 21. Spring pin for 3rd-4th speed shift fork
- ©** **Y** 22. Spring pin for 1st-2nd speed shift fork
- ©** **X** 23. Spring pin for OD-R shift fork
- 24. OD-R shift rail
- 25. 3rd-4th speed shift rail
- 26. OD-R shift fork
- 27. Interlock plunger
- V** 28. Countershaft lock nut
- U** 29. Countershaft rear bearing
- 30. Counter overdrive gear
- 31. 1st-2nd speed shift rail

R5M21-1-B (KM132-L)

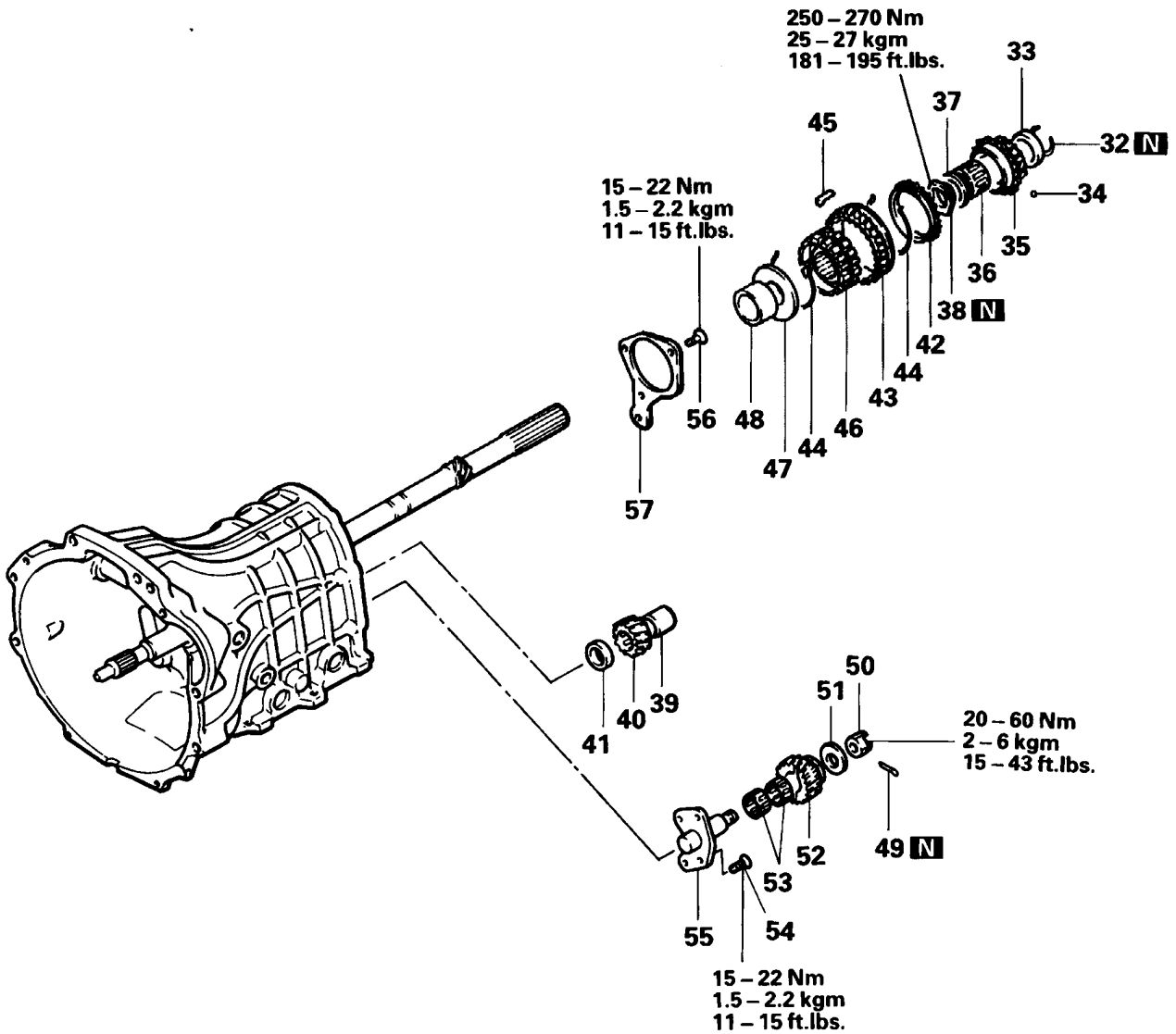

Disassembly steps

- 32. Snap ring
- 33. Spacer
- 34. Steel ball
- 35. Overdrive gear
- 36. Needle bearing
- 37. Bearing spacer
- ⓔ Ⓢ 38. Mainshaft lock nut
- 39. Spacer
- 40. Counter reverse gear
- 41. Spacer
- Ⓚ 42. Overdrive synchronizer ring
- Ⓚ 43. OD-R synchronizer sleeve
- Ⓚ 44. OD-R synchronizer spring
- Ⓚ 45. OD-R synchronizer key
- Ⓚ 46. OD-R synchronizer hub
- 47. Stopper plate
- 48. Spacer
- 49. Split pin
- 50. Slotted nut
- 51. Thrust washer
- 52. Reverse idler gear
- 53. Needle bearing
- Ⓚ 54. Bolt
- Ⓚ Ⓚ 55. Reverse idler gear shaft
- Ⓚ Ⓚ 56. Bolt
- 57. Rear bearing retainer

R5M21-1-B (KM132-L)

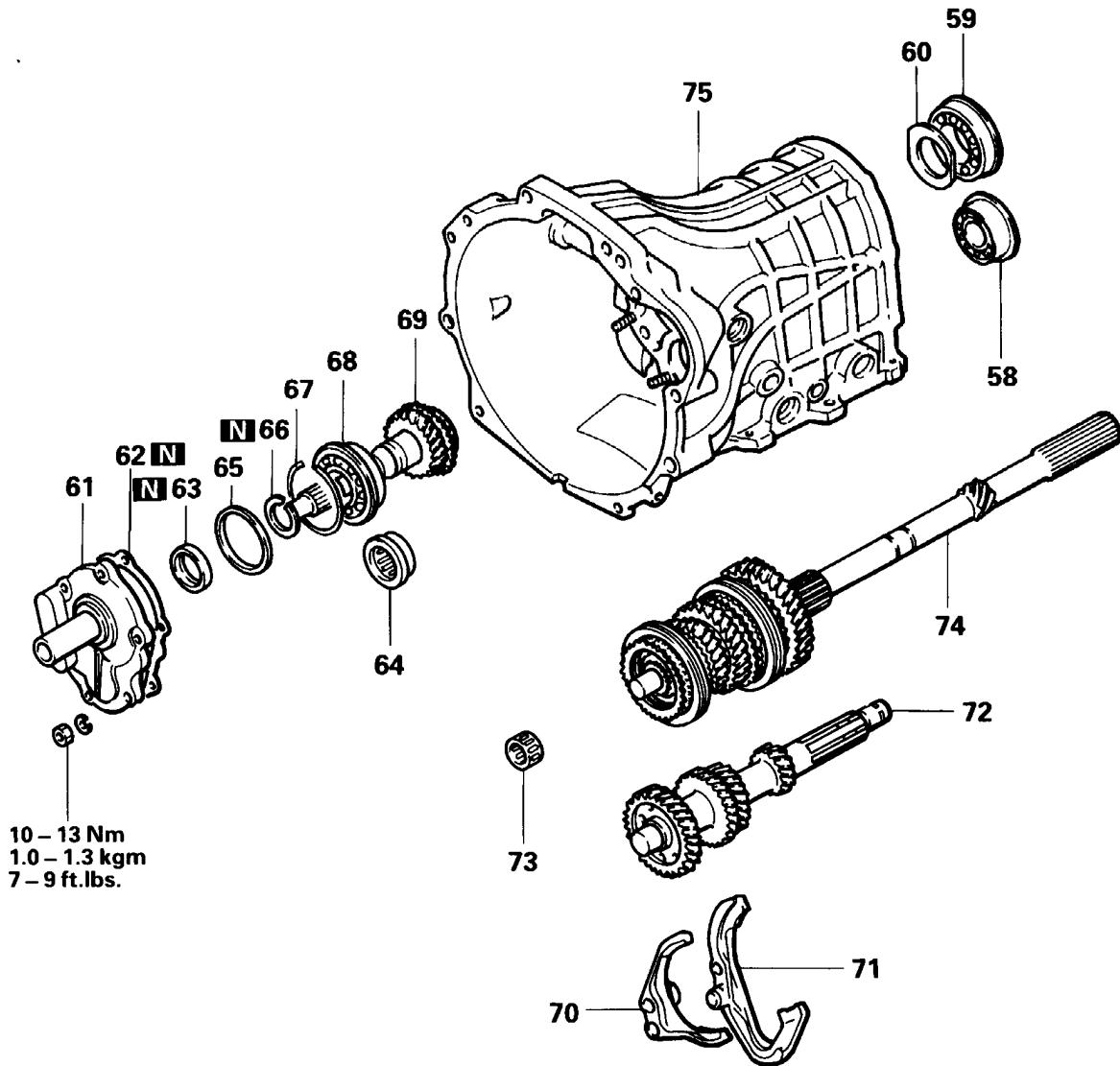

10 – 13 Nm
1.0 – 1.3 kgm
7 – 9 ft.lbs.

Disassembly steps

- Ⓜ Ⓜ 58. Countershaft center bearing
- Ⓜ Ⓜ 59. Mainshaft center bearing
- 60. Bearing spacer
- 61. Front bearing retainer
- Ⓜ 62. Front bearing retainer gasket
- Ⓜ 63. Oil seal
- Ⓜ 64. Countershaft front bearing
- Ⓜ 65. Spacer
- Ⓜ 66. Snap ring
- Ⓜ 67. Snap ring
- Ⓜ Ⓜ 68. Maindrive gear bearing
- Ⓜ 69. Maindrive gear
- 70. 3rd-4th speed shift fork
- 71. 1st-2nd speed shift fork
- 72. Countershaft
- 73. Mainshaft front bearing
- 74. Mainshaft assembly
- 75. Transmission case

R5M21-1-G, R5M21-5-G

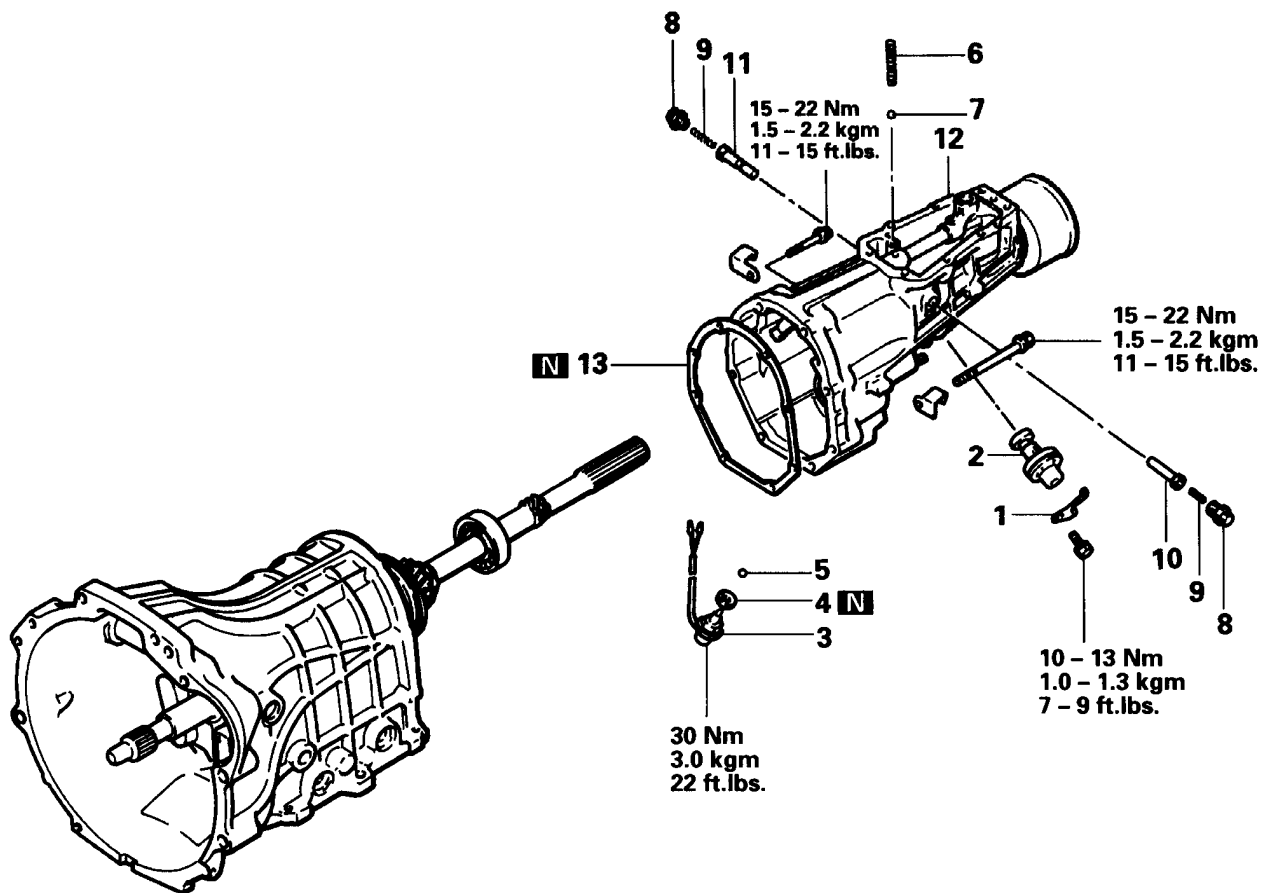

Disassembly steps

- 1. Sleeve clamp
- g 2. Speedometer gear
- 3. Backup lamp switch
- 4. Gasket
- 5. Steel ball
- 6. Resistance spring
- 7. Steel ball
- r 8. Seal plug
- 9. Spring
- q 10. Neutral plunger A
- q 11. Neutral plunger B
- B i 12. Extension housing
- h 13. Extension housing gasket

R5M21-1-G, R5M21-5-G

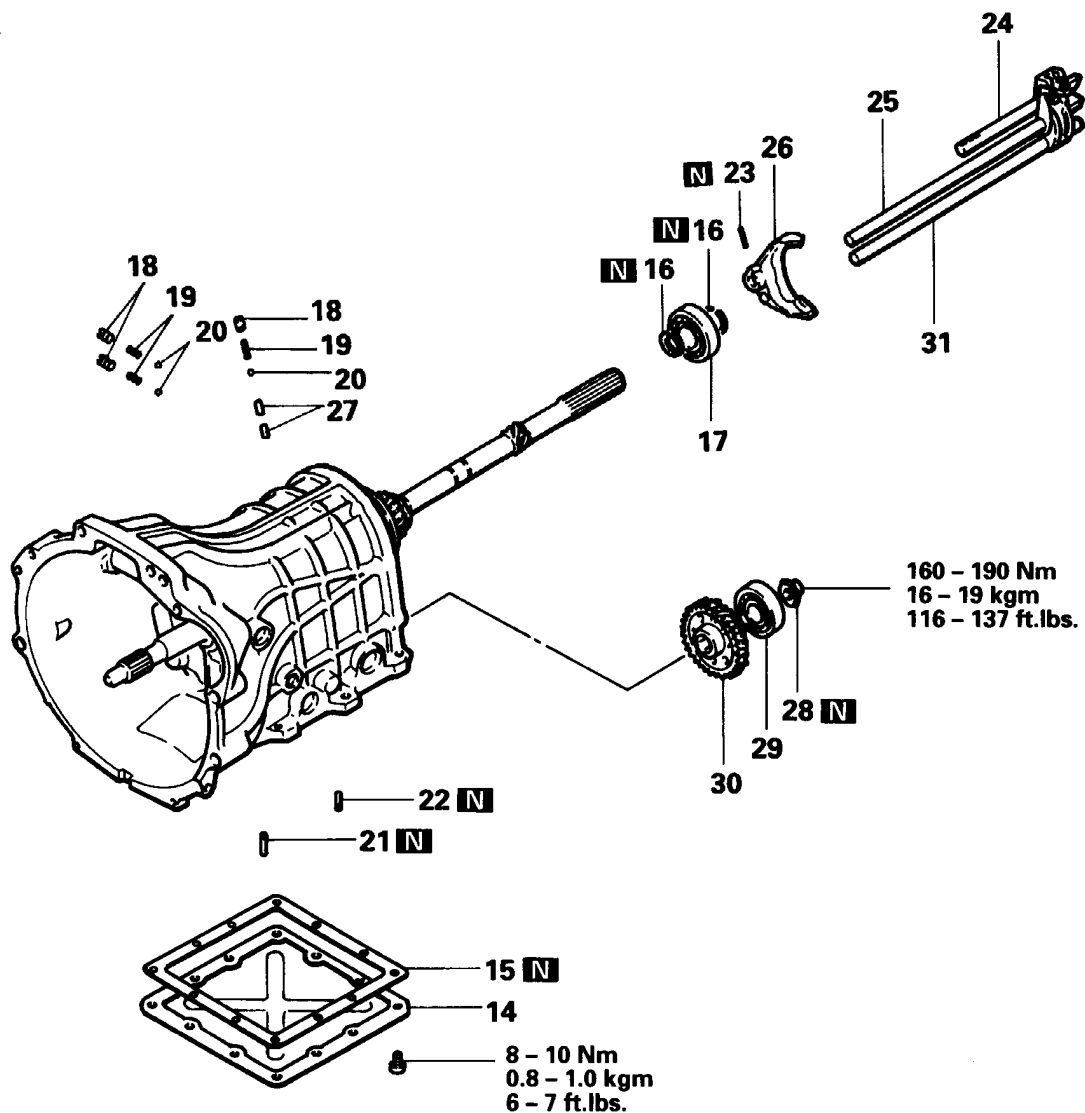

Disassembly steps

- 14. Under cover
- 15. Under cover gasket
- P** 16. Snap ring
- P** 17. Mainshaft rear bearing
- 18. Poppet plug
- b** 19. Poppet spring
- b** 20. Steel ball
- C** **Y** 21. Spring pin for 3rd-4th speed shift fork
- C** **Y** 22. Spring pin for 1st-2nd speed shift fork
- D** **X** 23. Spring pin for OD-R shift fork
- 24. OD-R shift rail
- 25. 3rd-4th speed shift rail
- 26. OD-R shift fork
- 27. Interlock plunger
- V** 28. Countershaft lock nut
- U** 29. Countershaft rear bearing
- 30. Counter overdrive gear
- 31. 1st-2nd speed shift rail

TRM0061

R5M21-1-G, R5M21-5-G

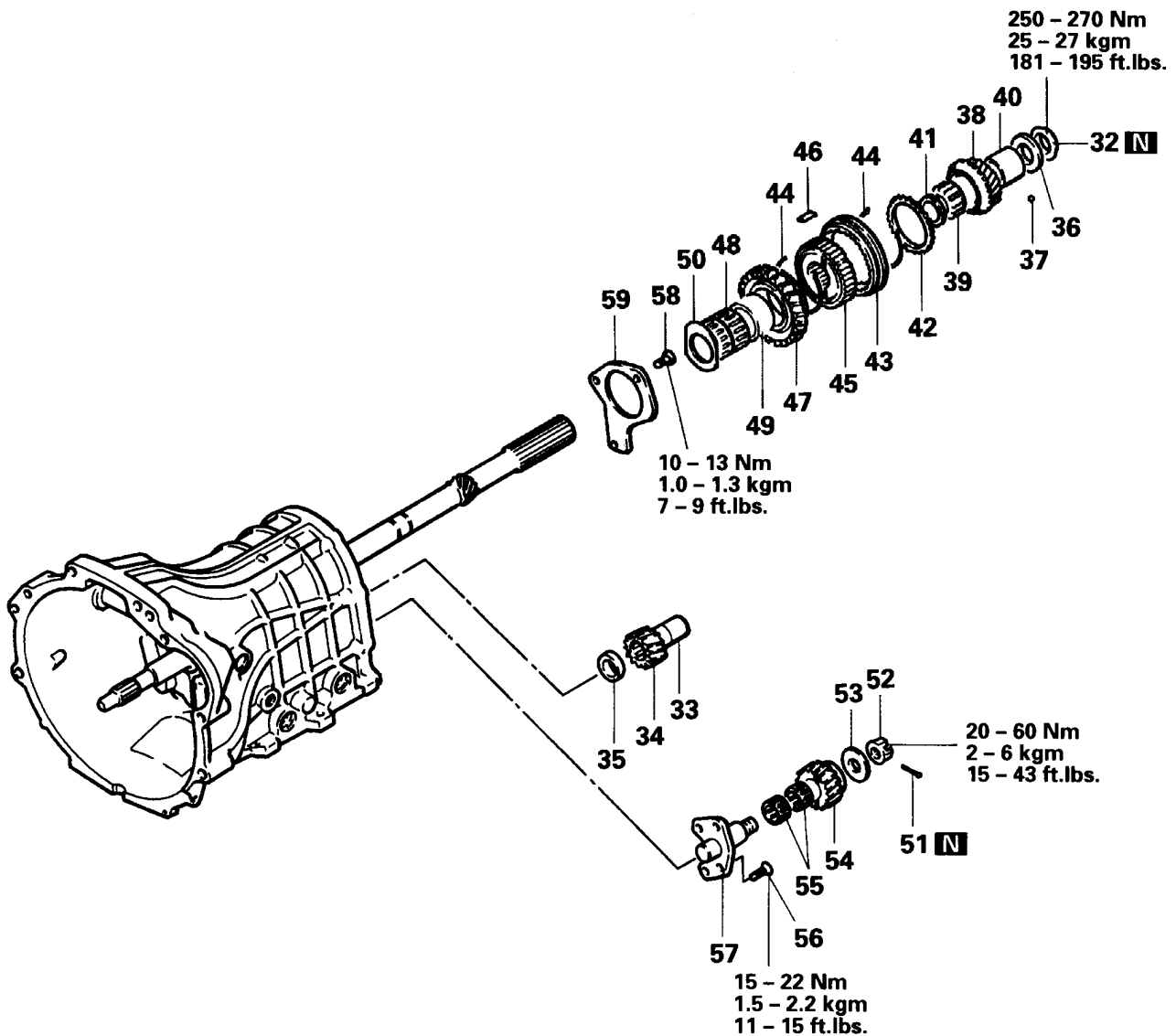
**Disassembly steps**

- (E) (S) 32. Mainshaft lock nut
 33. Spacer
 34. Counter reverse gear
 35. Spacer
 36. Spacer
 37. Steel ball
 38. Overdrive gear
 39. Needle bearing
 (F) (R) 40. Bearing sleeve
 41. Bearing spacer
 (Q) 42. Overdrive synchronizer ring
 (O) 43. OD-R synchronizer sleeve
 (P) 44. OD-R synchronizer spring
 (O) 45. OD-R synchronizer hub
 (P) 46. OD-R synchronizer key
 47. Reverse gear
 48. Needle bearing
 (N) 49. Bearing sleeve
 50. Spacer
 51. Split pin
 52. Slotted nut
 53. Thrust washer
 54. Reverse idler gear
 55. Needle bearing
 (L) 56. Bolt
 (G) (L) 57. Reverse idler gear shaft
 (K) 58. Bolt
 59. Rear bearing retainer

R5M21-1-P (KM132-J)

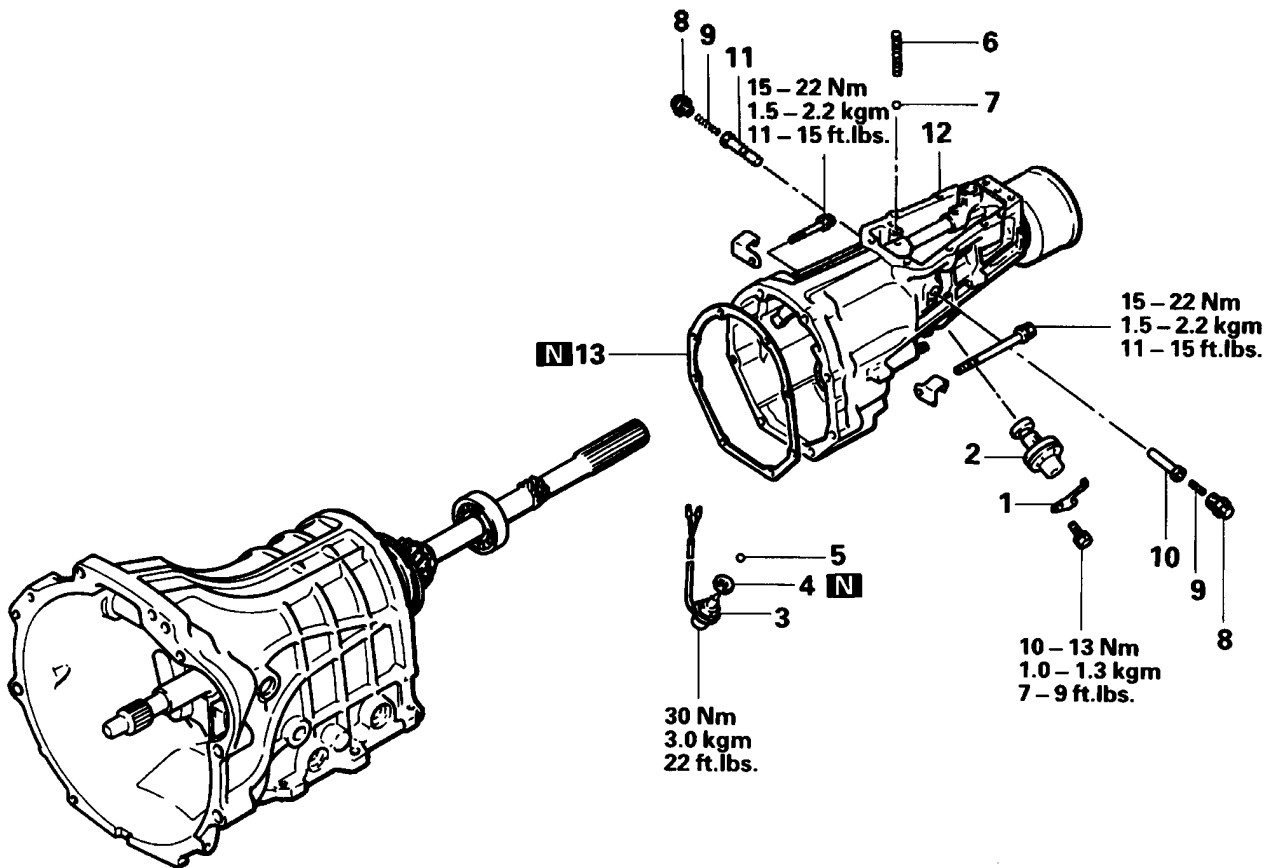

Disassembly steps

- 1. Sleeve clamp
- g** 2. Speedometer gear
- 3. Backup lamp switch
- 4. Gasket
- 5. Steel ball
- 6. Resistance spring
- 7. Steel ball
- r** 8. Seal plug
- 9. Spring
- q** 10. Neutral plunger A
- q** 11. Neutral plunger B
- B** **i** 12. Extension housing
- h** 13. Extension housing gasket

R5M21-1-P (KM132-J)

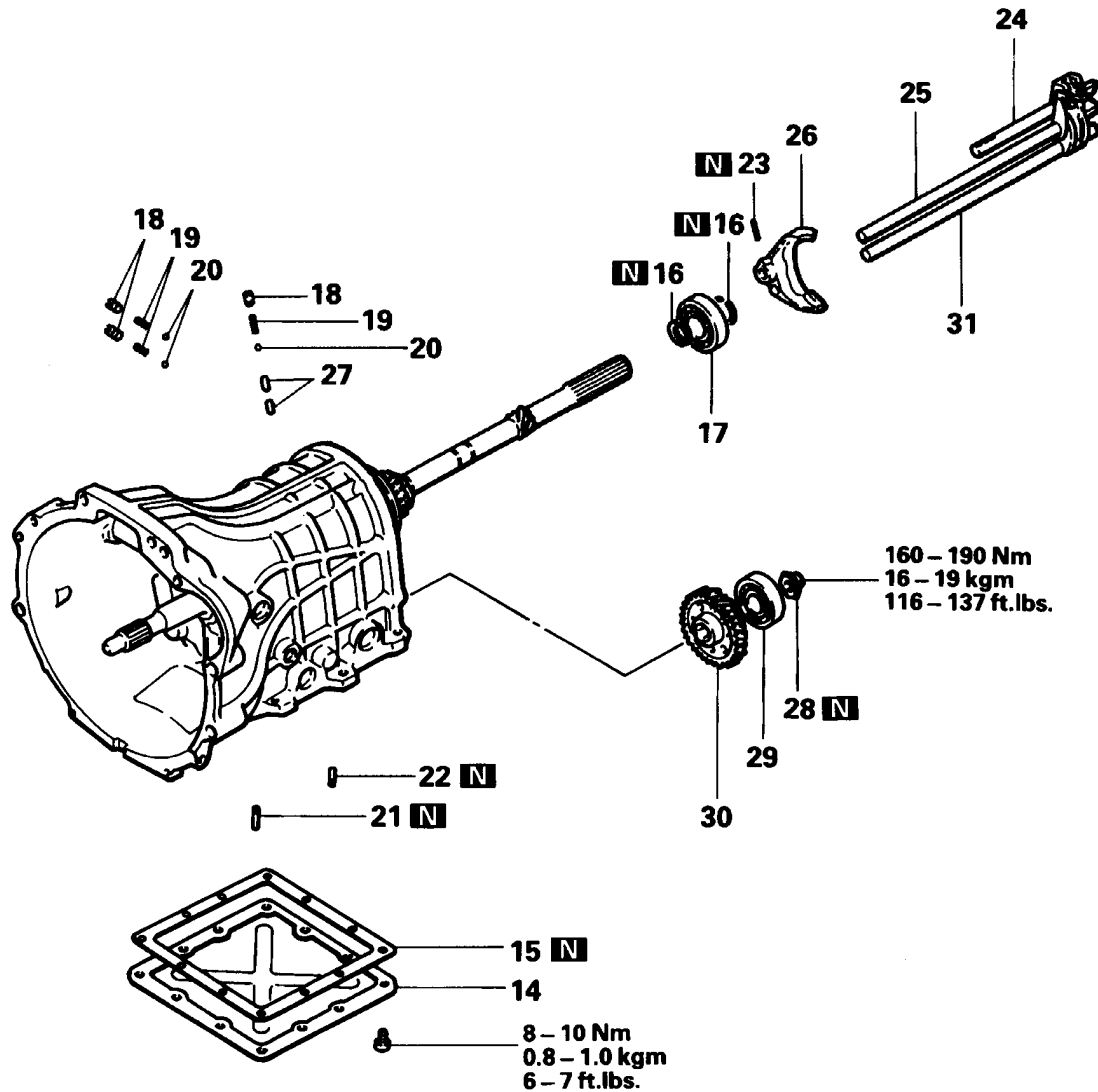

Disassembly steps

- 14. Under cover
- 15. Under cover gasket
- P 16. Snap ring
- P 17. Mainshaft rear bearing
- 18. Poppet plug
- b 19. Poppet spring
- b 20. Steel ball
- C Y 21. Spring pin for 3rd-4th speed shift fork
- C Y 22. Spring pin for 1st-2nd speed shift fork
- D X 23. Spring pin for OD-R shift fork
- 24. OD-R shift rail
- 25. 3rd-4th speed shift rail
- 26. OD-R shift fork
- 27. Interlock plunger
- V U 28. Countershaft lock nut
- U 29. Countershaft rear bearing
- 30. Counter overdrive gear
- 31. 1st-2nd speed shift rail

R5M21-1-P (KM132-J)

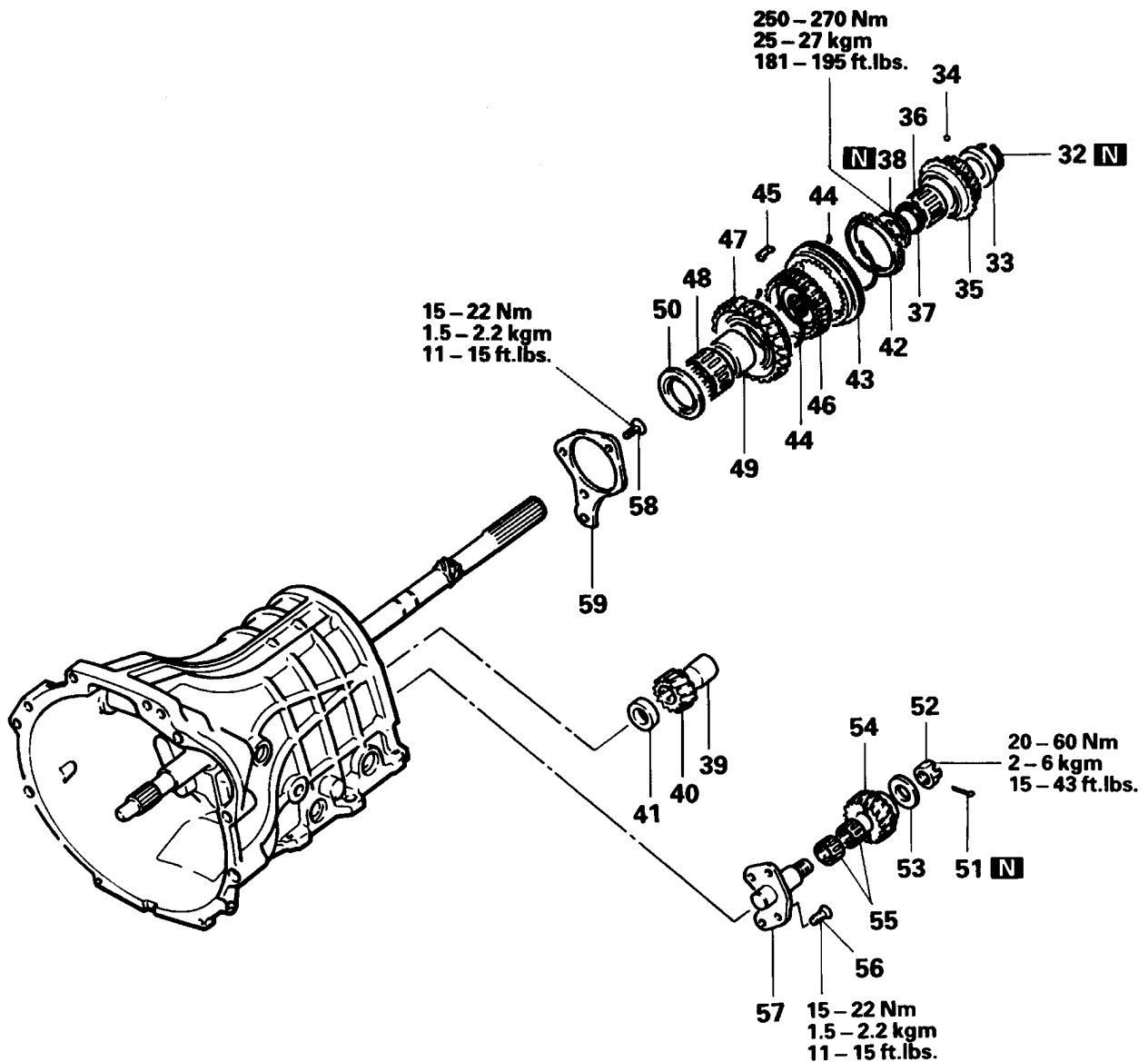

Disassembly steps

- 32. Snap ring
- 33. Spacer
- 34. Steel ball
- 35. Overdrive gear
- 36. Needle bearing
- 37. Bearing spacer
- (E) (S) 38. Mainshaft lock nut
- 39. Spacer
- 40. Counter reverse gear
- 41. Spacer
- (Q) 42. OD-R synchronizer ring
- (O) 43. OD-R synchronizer sleeve
- (P) 44. OD-R synchronizer spring
- (P) 45. OD-R synchronizer key
- (Q) 46. OD-R synchronizer hub
- 47. Reverse gear
- (N) 48. Needle bearing
- (N) 49. Bearing sleeve
- 50. Spacer
- 51. Split pin
- 52. Slotted nut
- 53. Thrust washer
- 54. Reverse idler gear
- 55. Needle bearing
- (L) 56. Bolt
- (G) (L) 57. Reverse idler gear shaft
- (K) 58. Bolt
- 59. Rear bearing retainer

R5M21-1-P (KM132-J)

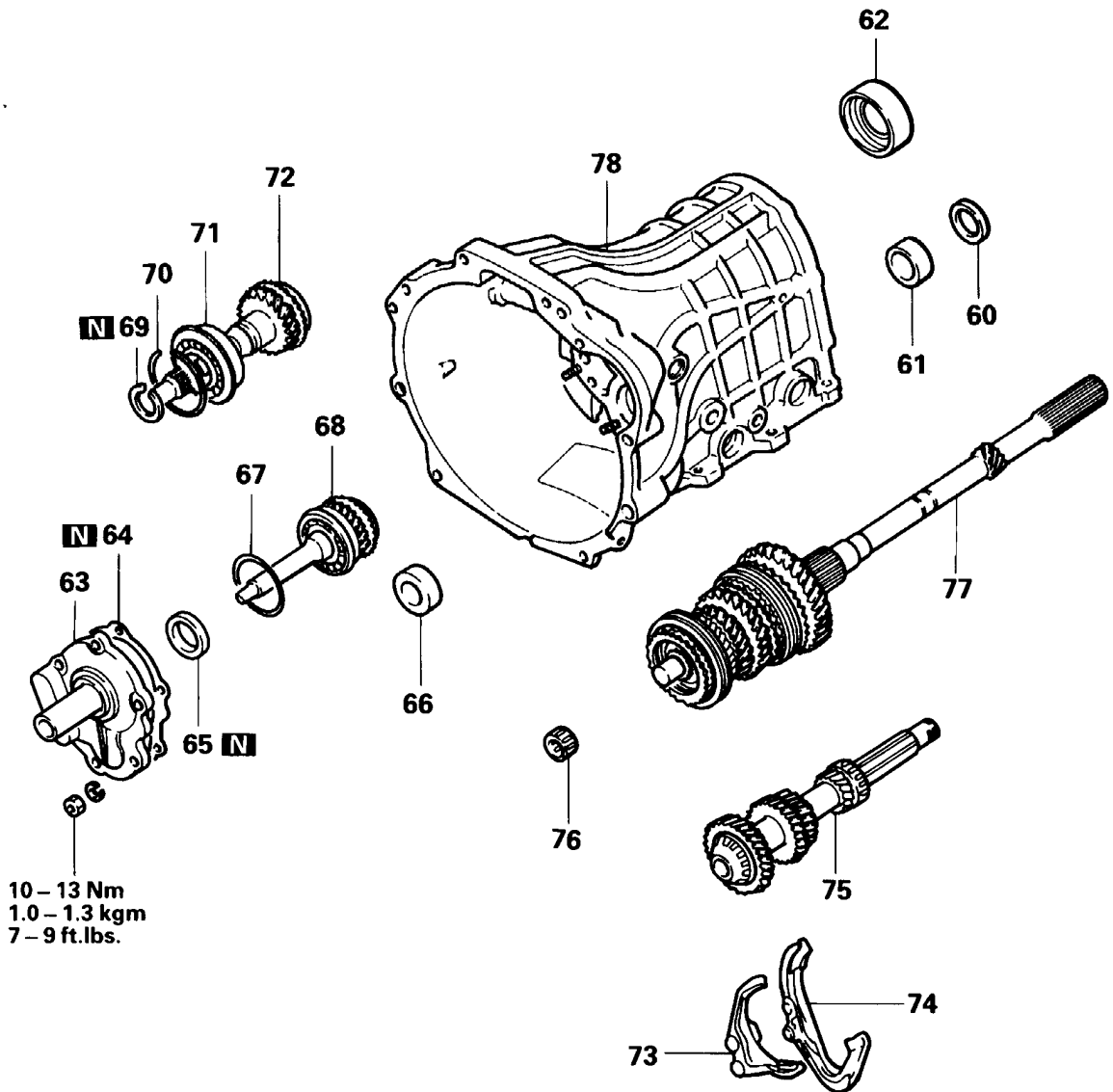

Disassembly steps

- Ⓧ J 60. Spacer
- Ⓧ H 61. Countershaft center bearing outer race
- Ⓧ I 62. Mainshaft center bearing
- Ⓧ G 63. Front bearing retainer
- Ⓧ F 64. Front bearing retainer gasket
- Ⓧ E 65. Oil seal
- Ⓧ D 66. Countershaft front bearing outer race
- Ⓧ C 67. Spacer
- Ⓧ B 68. Maindrive gear assembly – Up to 1989
- Ⓧ A 69. Snap ring
- Ⓧ A 70. Snap ring
- Ⓧ K 71. Maindrive gear bearing } From 1990
- 72. Maindrive gear
- 73. 3rd-4th speed shift fork
- 74. 1st-2nd speed shift fork
- Ⓧ L 75. Countershaft assembly
- 76. Mainshaft front bearing
- 77. Mainshaft assembly
- 78. Transmission case

R5M21-1-D (KM132-H), R5M21-5-D, P

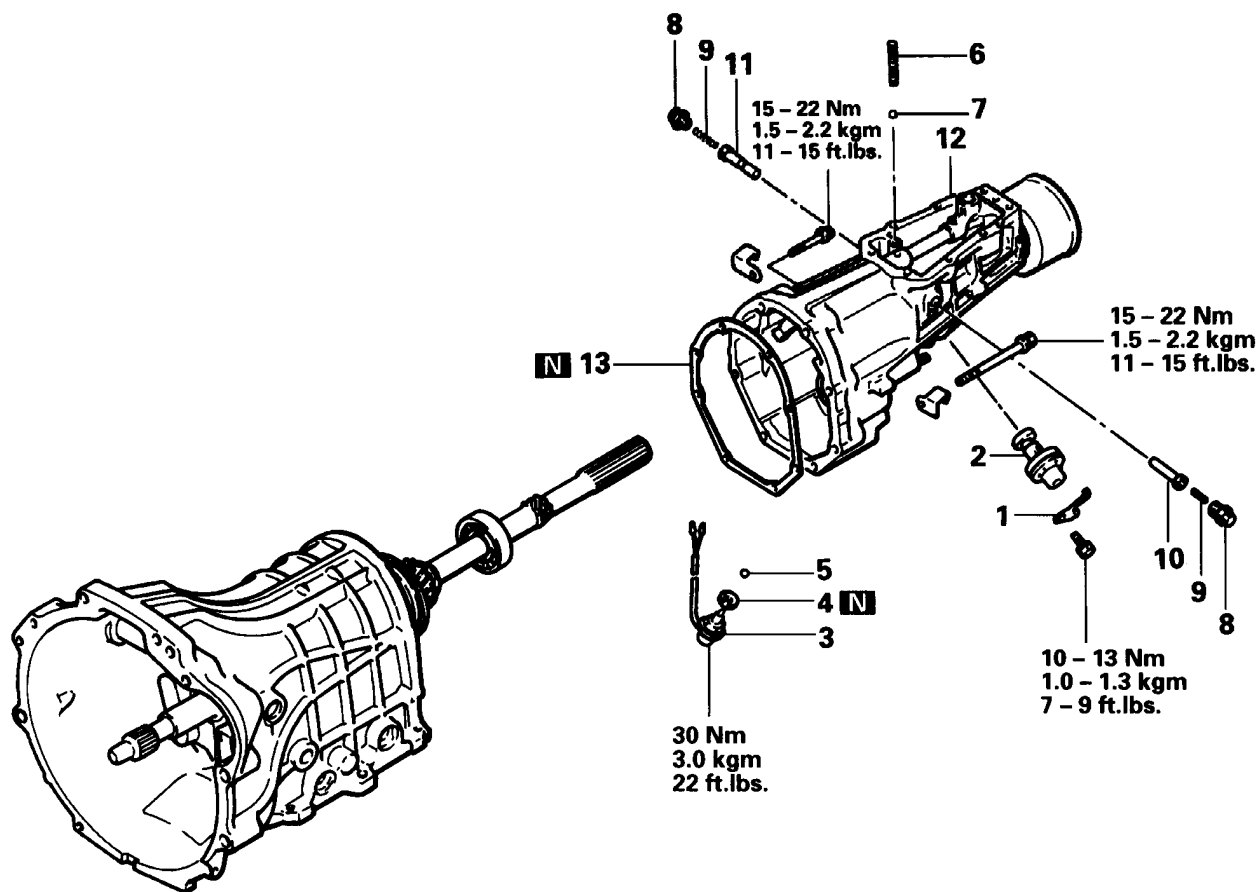
**Disassembly steps**

- 1. Sleeve clamp
- g** 2. Speedometer gear
- 3. Backup lamp switch
- 4. Gasket
- 5. Steel ball
- 6. Resistance spring
- 7. Steel ball
- r** 8. Seal plug
- 9. Spring
- q** 10. Neutral plunger A
- q** 11. Neutral plunger B
- B** **i** 12. Extension housing
- h** 13. Extension housing gasket

TRM0060

R5M21-1-D (KM132-H), R5M21-5-D, P

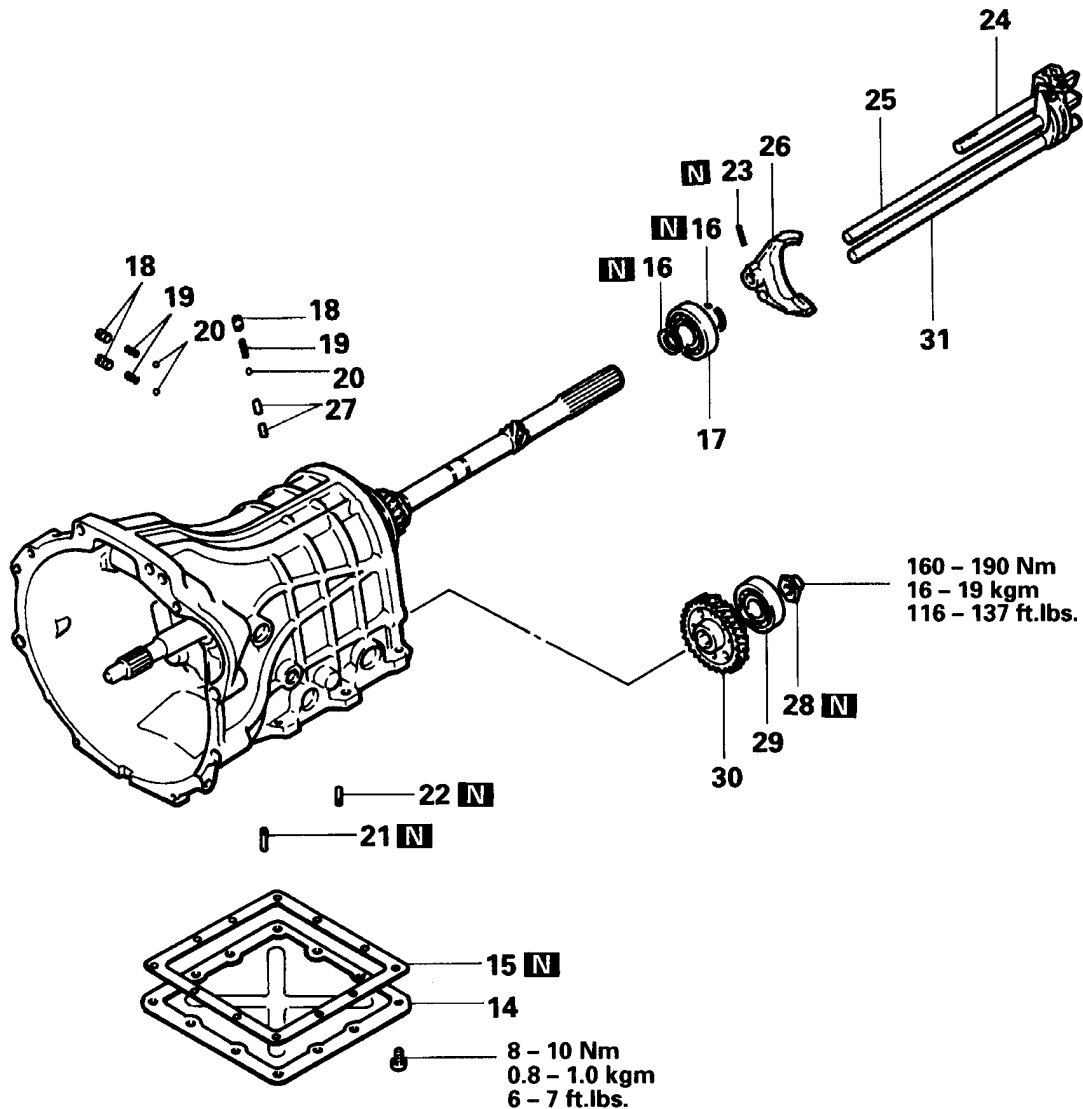

Disassembly steps

- 14. Under cover
- 15. Under cover gasket
- P** 16. Snap ring
- P** 17. Mainshaft rear bearing
- 18. Poppet plug
- b** 19. Poppet spring
- b** 20. Steel ball
- C** **Y** 21. Spring pin for 3rd-4th speed shift fork
- C** **Y** 22. Spring pin for 1st-2nd speed shift fork
- D** **X** 23. Spring pin for OD-R shift fork
- 24. OD-R shift rail
- 25. 3rd-4th speed shift rail
- 26. OD-R shift fork
- 27. Interlock plunger
- V** **U** 28. Countershaft lock nut
- V** **U** 29. Countershaft rear bearing
- 30. Counter overdrive gear
- 31. 1st-2nd speed shift rail

R5M21-1-D (KM132-H), R5M21-5-D, P

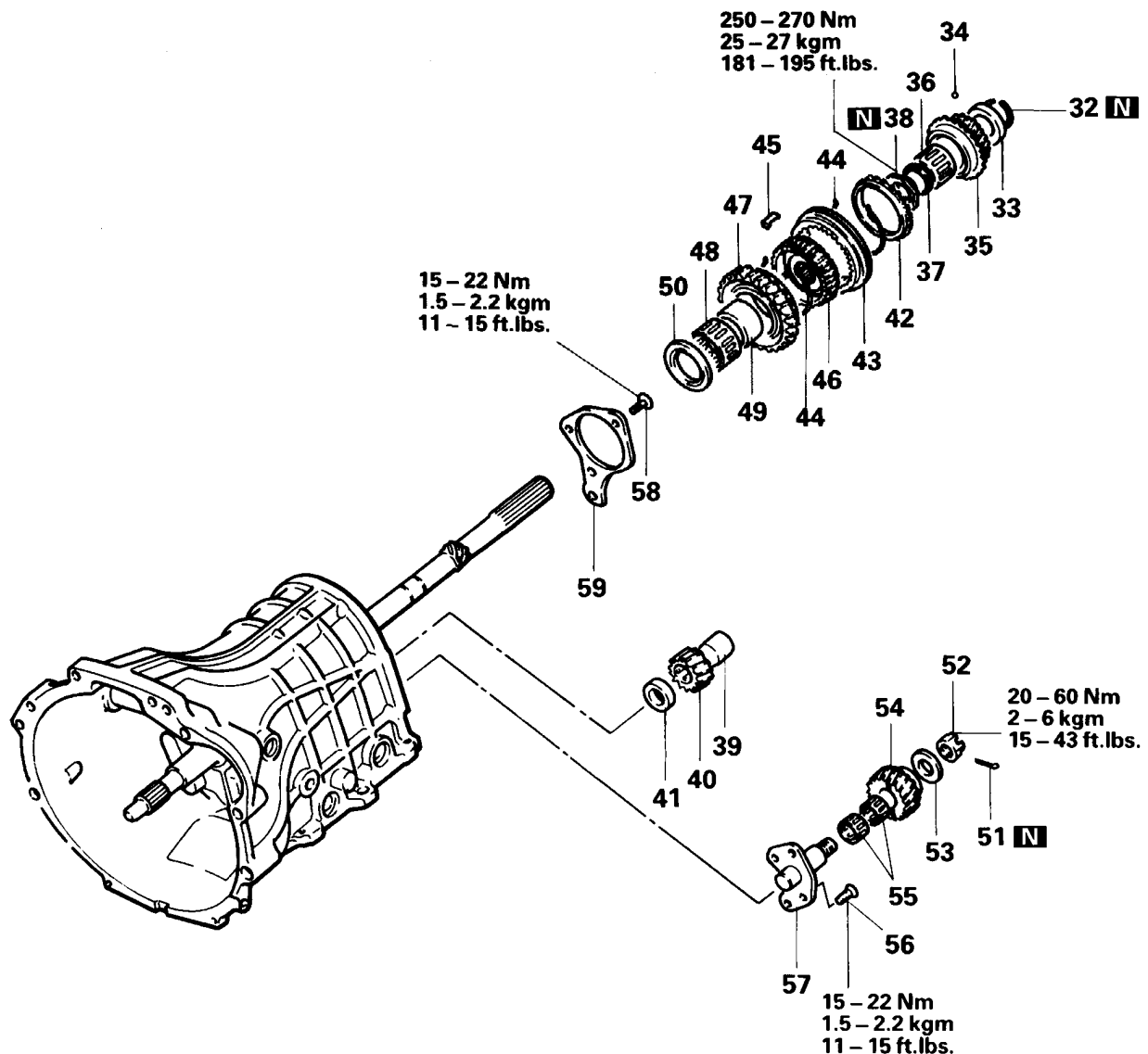
**Disassembly steps**

- 32. Snap ring
- 33. Spacer
- 34. Steel ball
- 35. Overdrive gear
- 36. Needle bearing
- 37. Bearing spacer
- (E) (S) 38. Mainshaft lock nut
- 39. Spacer
- 40. Counter reverse gear
- 41. Spacer
- (Q) 42. OD-R synchronizer ring
- (Q) 43. OD-R synchronizer sleeve
- (P) 44. OD-R synchronizer spring
- (P) 45. OD-R synchronizer key
- (Q) 46. OD-R synchronizer hub
- 47. Reverse gear
- (N) 48. Needle bearing
- (N) 49. Bearing sleeve
- 50. Spacer
- 51. Split pin
- 52. Slotted nut
- 53. Thrust washer
- 54. Reverse idler gear
- 55. Needle bearing
- (L) 56. Bolt
- (G) (L) 57. Reverse idler gear shaft
- (K) 58. Bolt
- 59. Rear bearing retainer

TRM0064

R5M21-1-D (KM132-H), R5M21-5-D, P

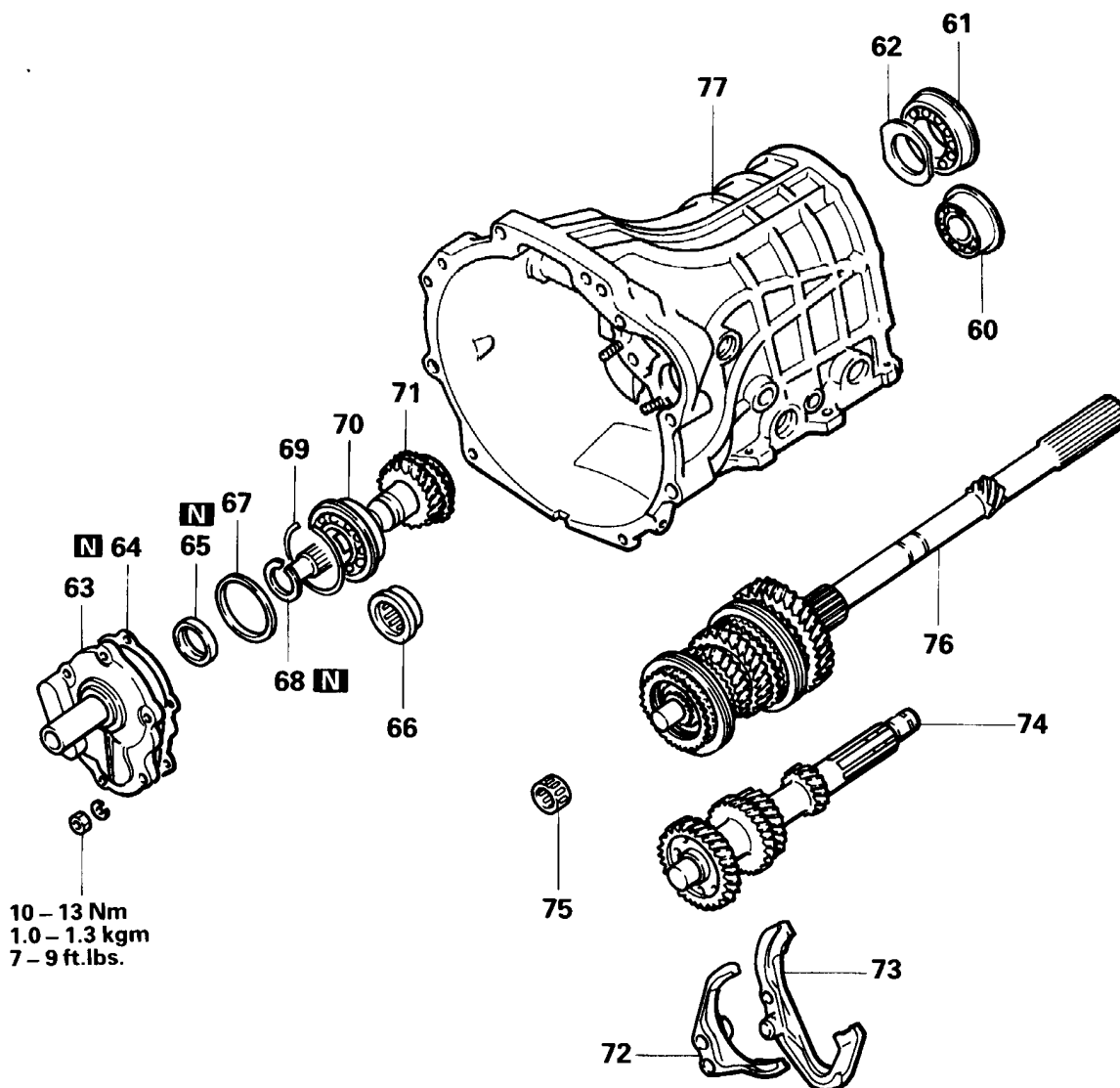

Disassembly steps

- (H) (I) 60. Countershaft center bearing
- (I) (H) 61. Mainshaft center bearing
- 62. Bearing spacer
- 63. Front bearing retainer
- (G) 64. Front bearing retainer gasket
- (E) 65. Oil seal
- (J) (D) 66. Countershaft front bearing
- (F) 67. Spacer
- (C) 68. Snap ring
- 69. Snap ring
- (K) (B) 70. Maindrive gear bearing
- 71. Maindrive gear
- 72. Countershaft
- 73. 3rd-4th speed shift fork
- 74. 1st-2nd speed shift fork
- 75. Mainshaft front bearing
- 76. Mainshaft assembly
- 77. Transmission case

R5M21-1-J (KM132-B, G, I)

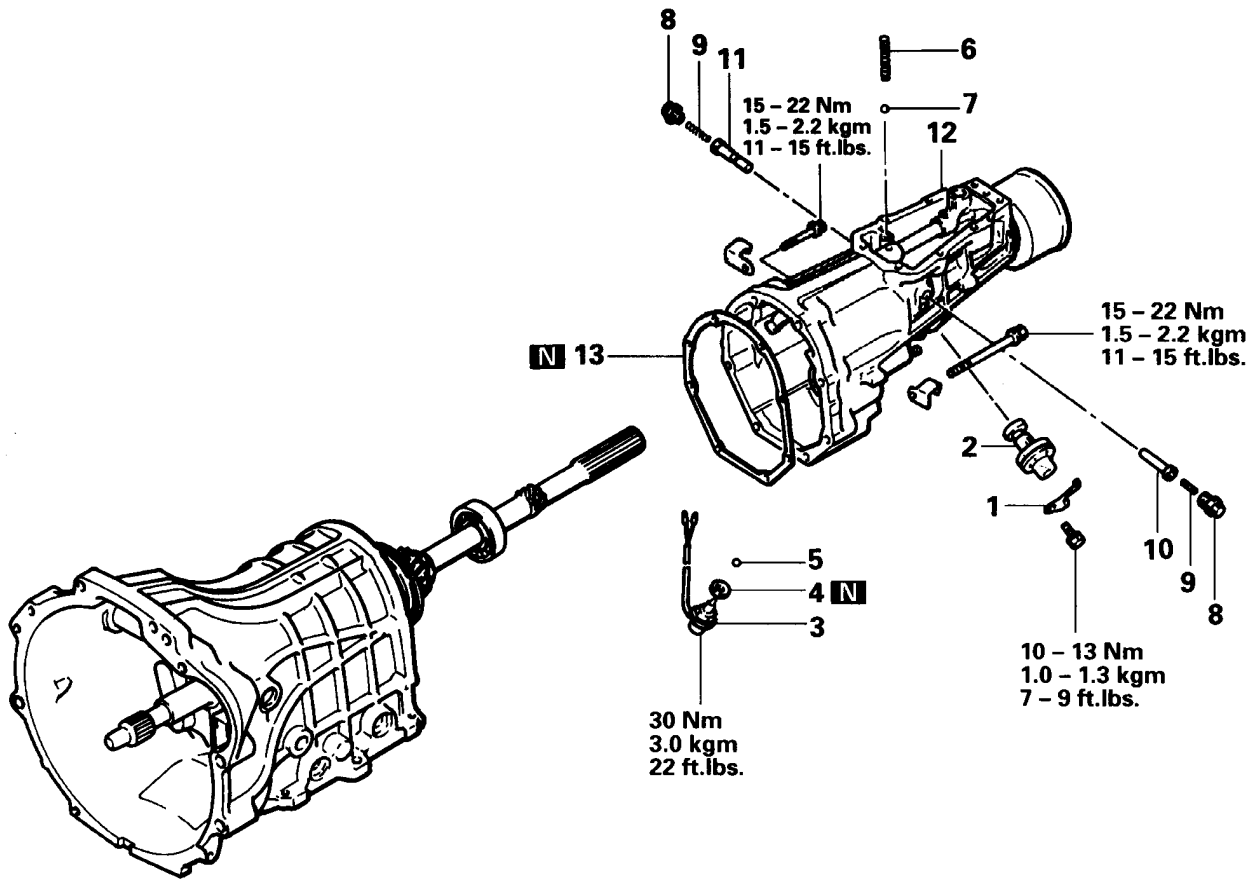
**Disassembly steps**

- 1. Sleeve clamp
- g 2. Speedometer gear
- 3. Backup lamp switch
- 4. Gasket
- 5. Steel ball
- 6. Resistance spring
- 7. Steel ball
- r 8. Seal plug
- 9. Spring
- q 10. Neutral plunger A
- q 11. Neutral plunger B
- ⓑ i 12. Extension housing
- h 13. Extension housing gasket

R5M21-1-J (KM132-B, G, I)

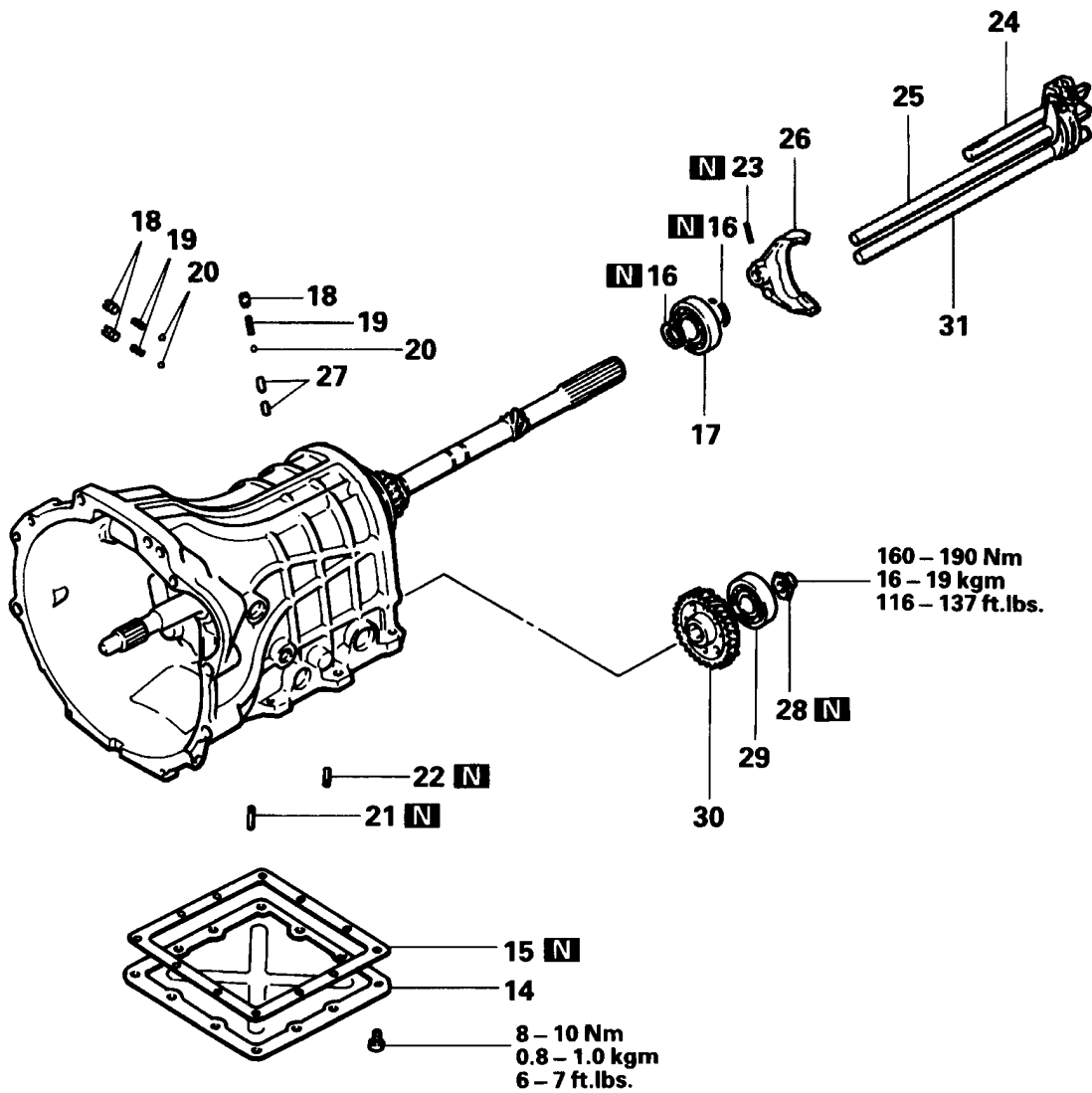

Disassembly steps

- 14. Under cover
- 15. Under cover gasket
- P** 16. Snap ring
- P** 17. Mainshaft rear bearing
- 18. Poppet plug
- b** 19. Poppet spring
- b** 20. Steel ball
- C** 21. Spring pin for 3rd-4th speed shift fork
- C** **Y** 22. Spring pin for 1st-2nd speed shift fork
- D** **X** 23. Spring pin for OD-R shift fork
- 24. OD-R shift rail
- 25. 3rd-4th speed shift rail
- 26. OD-R shift fork
- 27. Interlock plunger
- V** 28. Countershaft lock nut
- U** 29. Countershaft rear bearing
- 30. Counter overdrive gear
- 31. 1st-2nd speed shift rail

TRM0061

R5M21-1-J (KM132-B, G, I)

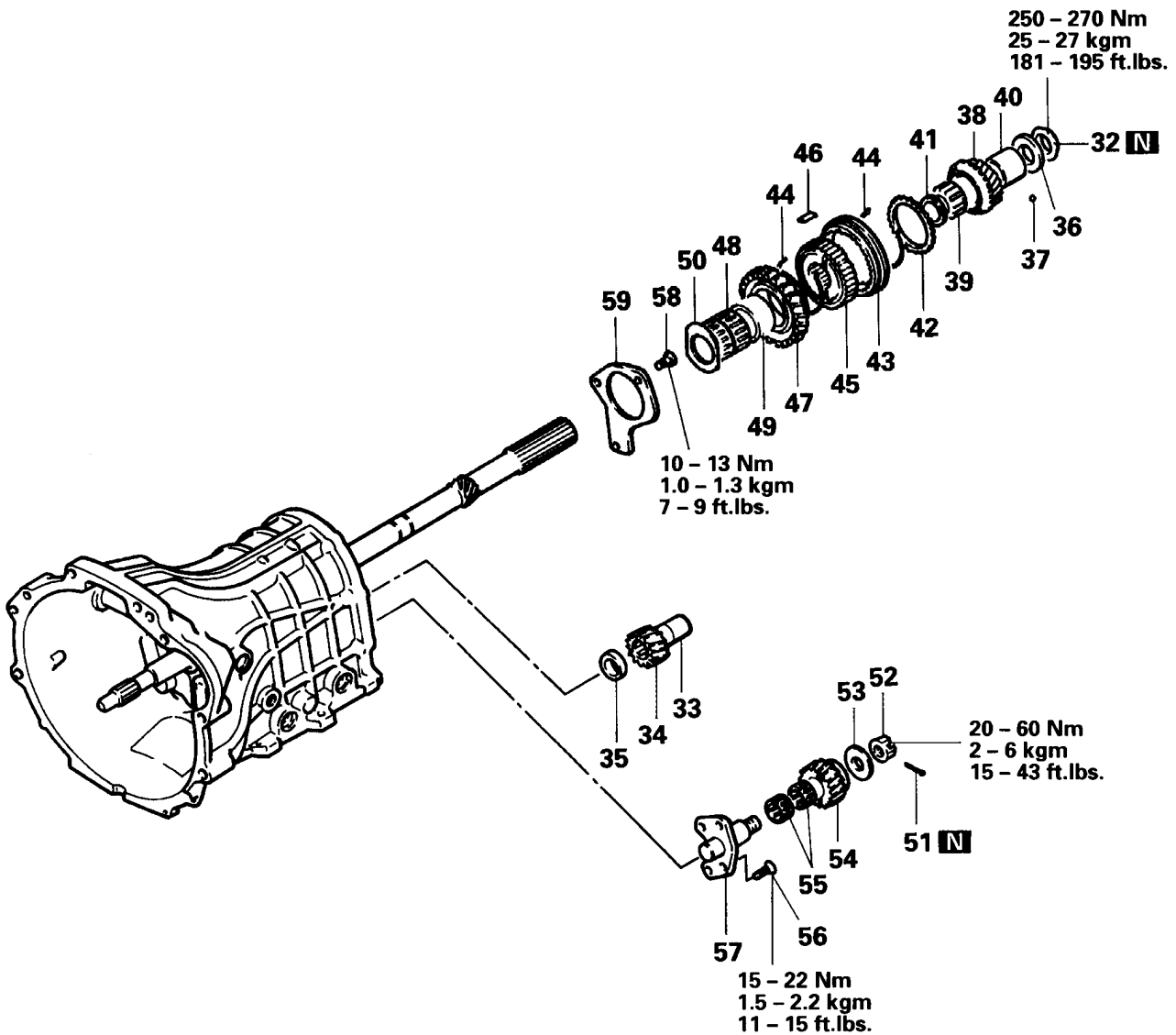

Disassembly steps

- Ⓔ Ⓢ 32. Mainshaft lock nut
- 33. Spacer
- 34. Counter reverse gear
- 35. Spacer
- 36. Spacer
- 37. Steel ball
- 38. Overdrive gear
- 39. Needle bearing
- Ⓕ Ⓡ 40. Bearing sleeve
- 41. Bearing spacer
- Ⓠ 42. Overdrive synchronizer ring
- Ⓡ 43. OD-R synchronizer sleeve
- Ⓟ 44. OD-R synchronizer spring
- Ⓡ 45. OD-R synchronizer hub
- Ⓟ 46. OD-R synchronizer key
- 47. Reverse gear
- Ⓝ 48. Needle bearing
- Ⓝ 49. Bearing sleeve
- 50. Spacer
- 51. Split pin
- 52. Slotted nut
- 53. Thrust washer
- 54. Reverse idler gear
- 55. Needle bearing
- Ⓛ 56. Bolt
- Ⓒ Ⓛ 57. Reverse idler gear shaft
- Ⓚ 58. Bolt
- 59. Rear bearing retainer

R5M21-1-J (KM132-B, G, I)

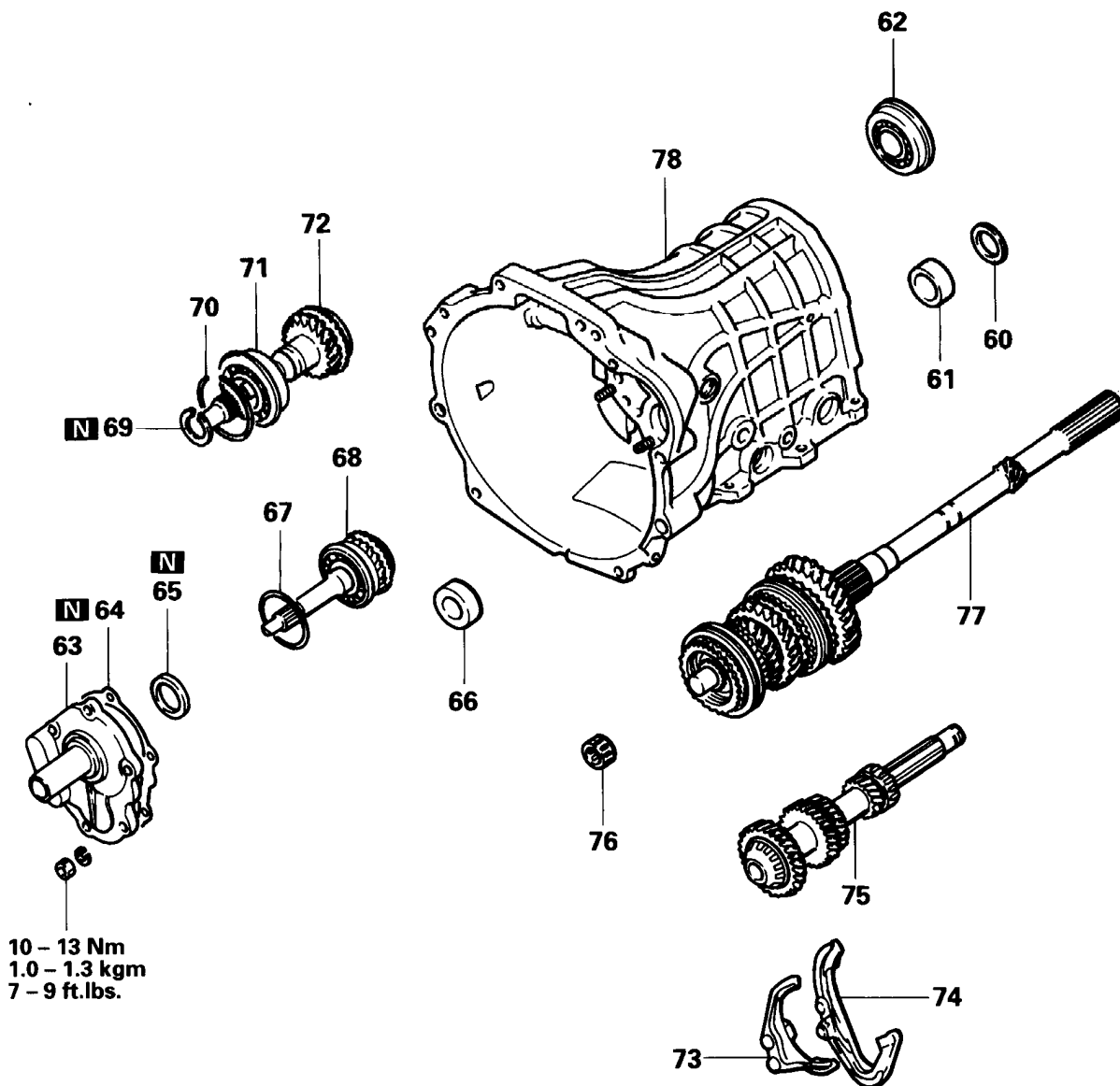

10 – 13 Nm
1.0 – 1.3 kgm
7 – 9 ft.lbs.

Disassembly steps

- J 60. Spacer
- 61. Countershaft center bearing outer race
- 62. Mainshaft center bearing
- 63. Front bearing retainer
- G 64. Front bearing retainer gasket
- E 65. Oil seal
- F 66. Countershaft front bearing outer race
- 67. Spacer
- 68. Maindrive gear assembly – Up to 1989
- C 69. Snap ring
- 70. Snap ring
- K B 71. Maindrive gear bearing } From 1990
- 72. Maindrive gear
- 73. 3rd-4th speed shift fork
- 74. 1st-2nd speed shift fork
- L A 75. Countershaft assembly
- 76. Mainshaft front bearing
- 77. Mainshaft assembly
- 78. Transmission case

R5M21-4-K (KM132-M, N)

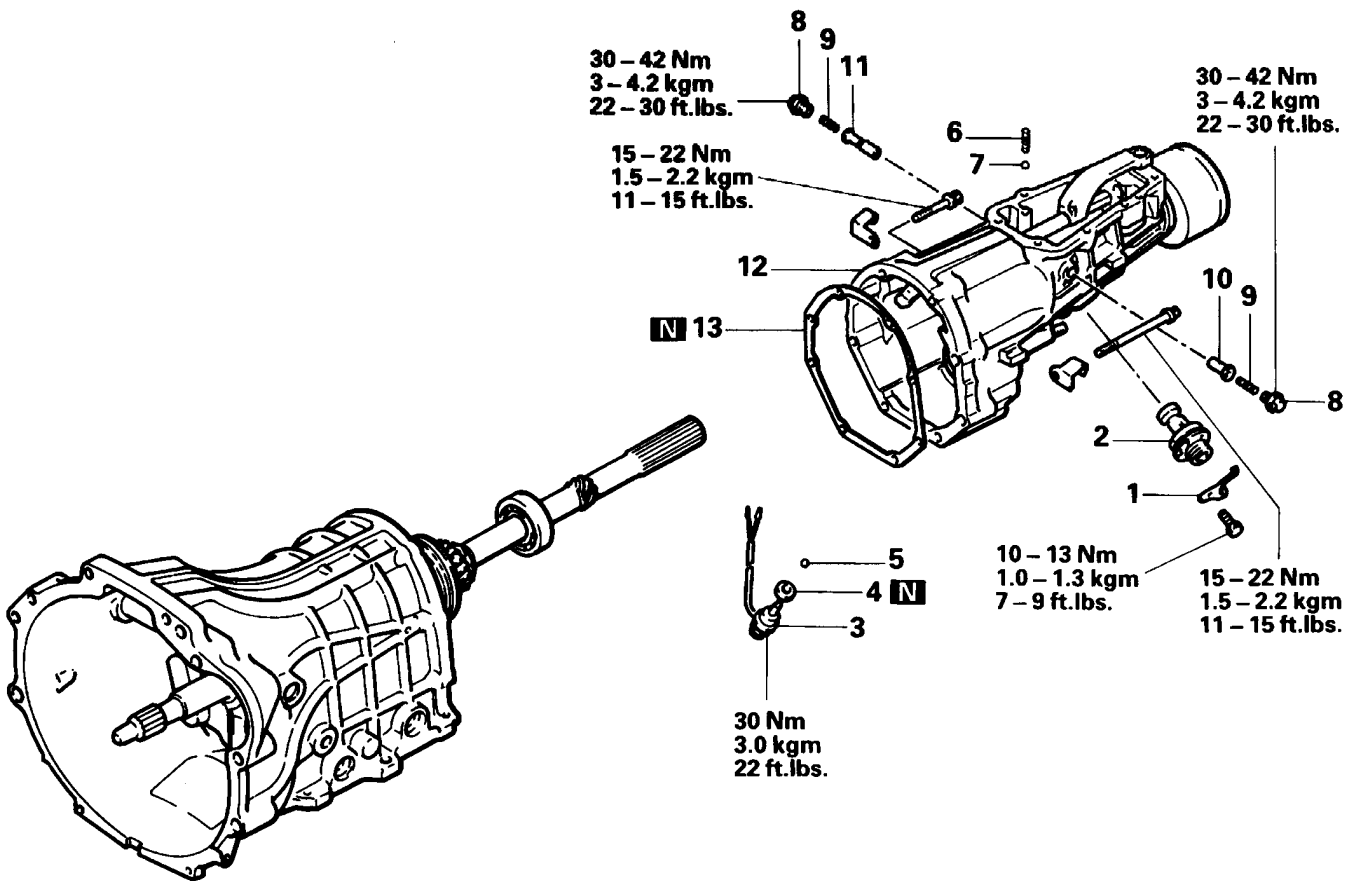

Disassembly steps

- 1. Sleeve clamp
- [g] 2. Speedometer gear
- 3. Backup lamp switch
- 4. Gasket
- 5. Steel ball
- 6. Resistance spring
- 7. Steel ball
- [r] 8. Seal plug
- 9. Spring
- [q] 10. Neutral plunger A
- [q] 11. Neutral plunger B
- [i] 12. Extension housing
- [h] 13. Extension housing gasket

R5M21-4-K (KM132-M, N)

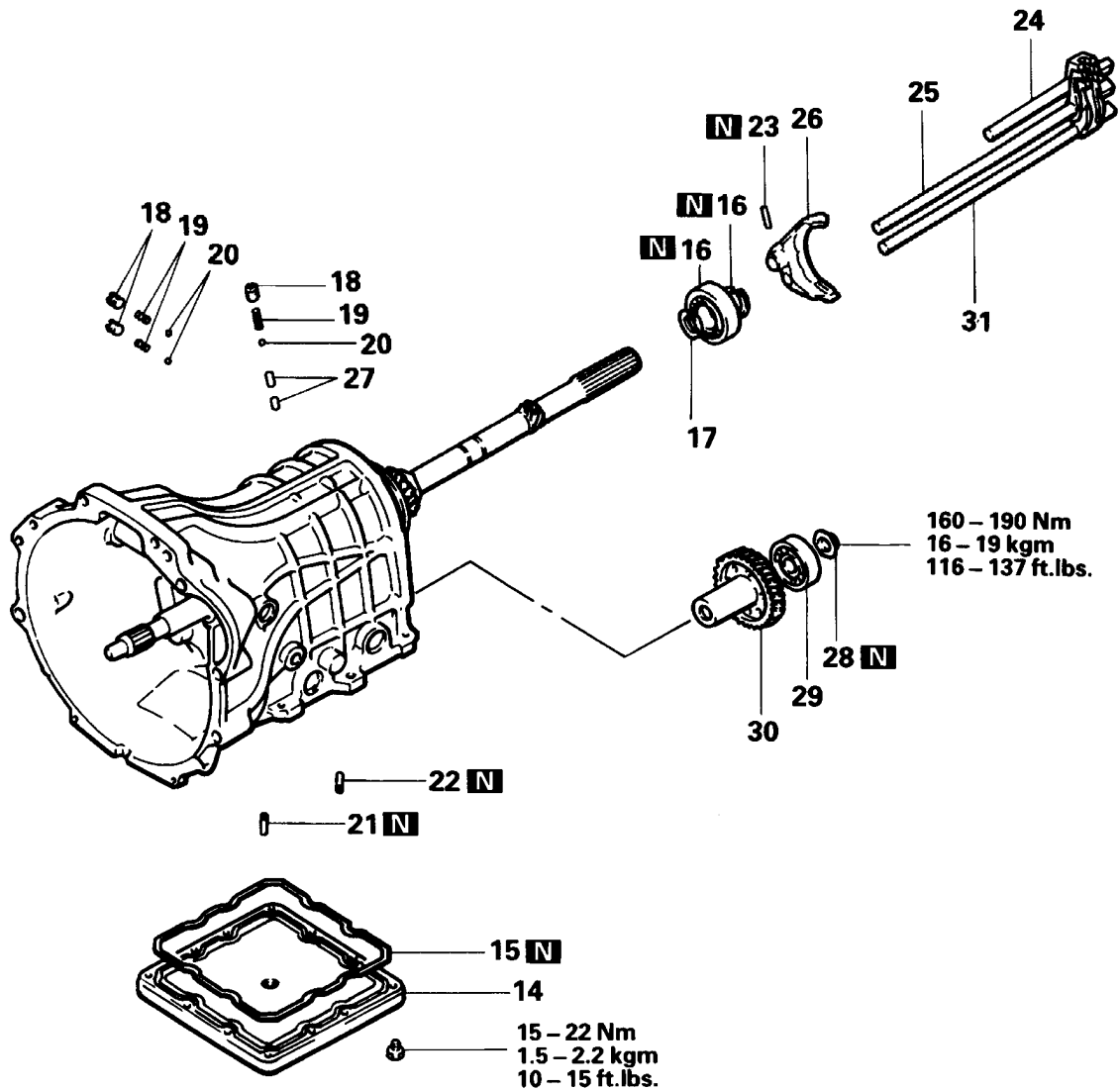

Disassembly steps

- 14. Under cover
- 15. O-ring
- P** 16. Snap ring
- P** 17. Mainshaft rear bearing
- 18. Poppet plug
- b** 19. Poppet spring
- b** 20. Steel ball
- Y** 21. Spring pin for 3rd-4th speed shift fork
- Y** 22. Spring pin for 1st-2nd speed shift fork
- X** 23. Spring pin for OD-R shift fork
- 24. OD-R shift rail
- 25. 3rd-4th speed shift rail
- 26. OD-R shift fork
- 27. Interlock plunger
- V** 28. Countershaft lock nut
- U** 29. Countershaft rear bearing
- 30. Counter overdrive gear
- 31. 1st-2nd speed shift rail

TRM0069

R5M21-4-K (KM132-M, N)

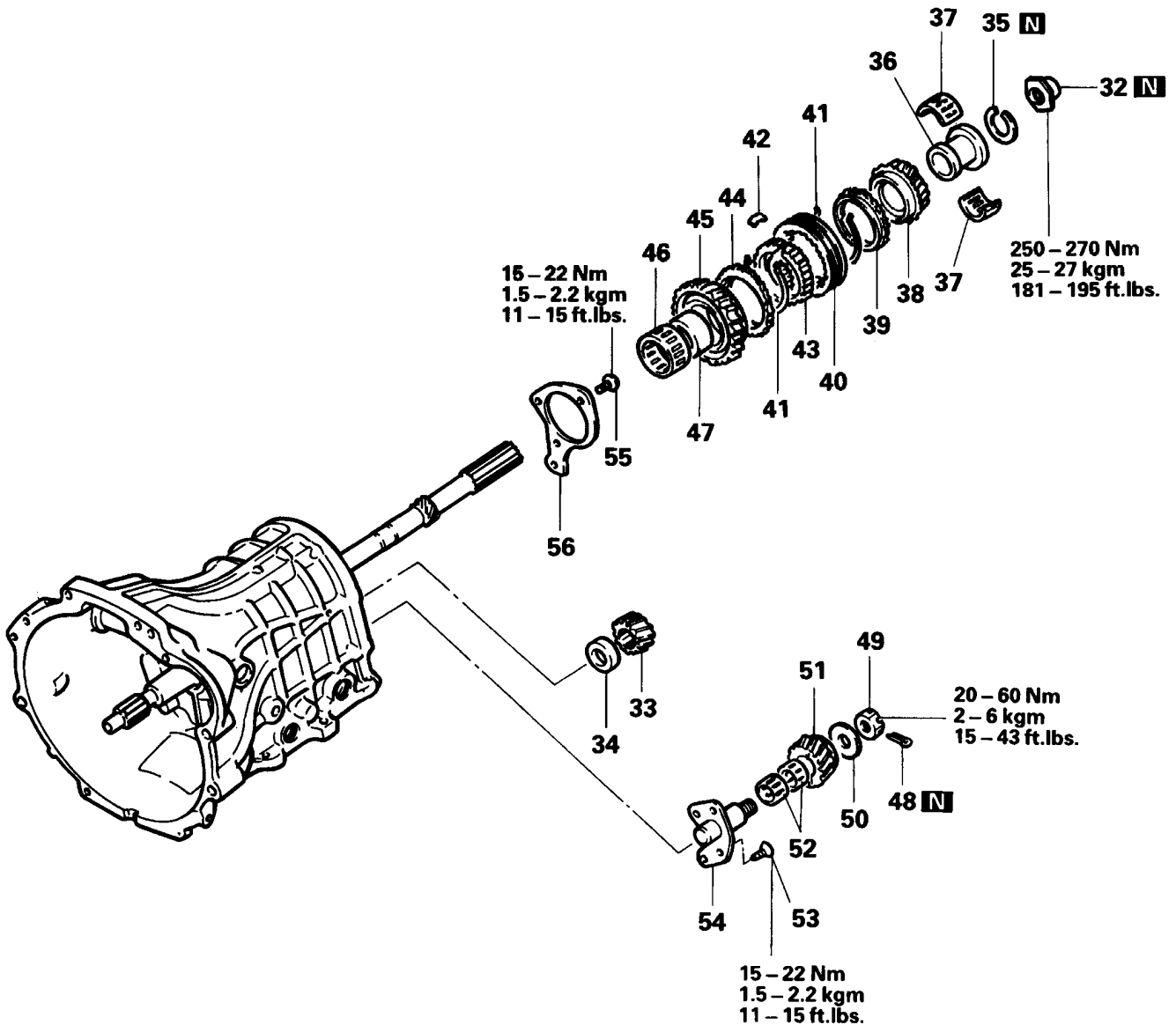

Disassembly steps

- ⓔ Ⓢ 32. Mainshaft lock nut
- 33. Reverse idler gear
- 34. Spacer
- Ⓣ 35. Snap ring
- Ⓡ 36. Overdrive gear sleeve
- Ⓡ 37. Needle bearing
- Ⓡ 38. Overdrive gear
- Ⓚ 39. Overdrive synchronizer ring
- Ⓚ 40. OD-R synchronizer sleeve
- Ⓚ 41. OD-R synchronizer spring
- Ⓚ 42. OD-R synchronizer key
- Ⓚ 43. OD-R synchronizer hub
- Ⓚ 44. Reverse synchronizer ring
- 45. Reverse gear

- Ⓝ 46. Needle bearing
- Ⓝ 47. Bearing sleeve
- 48. Split pin
- 49. Slotted nut
- 50. Thrust washer
- 51. Reverse idler gear
- 52. Needle bearing
- 53. Bolt
- Ⓞ Ⓛ 54. Reverse idler gear shaft
- Ⓞ Ⓚ 55. Bolt
- 56. Rear bearing retainer

R5M21-4-K (KM132-M, N)

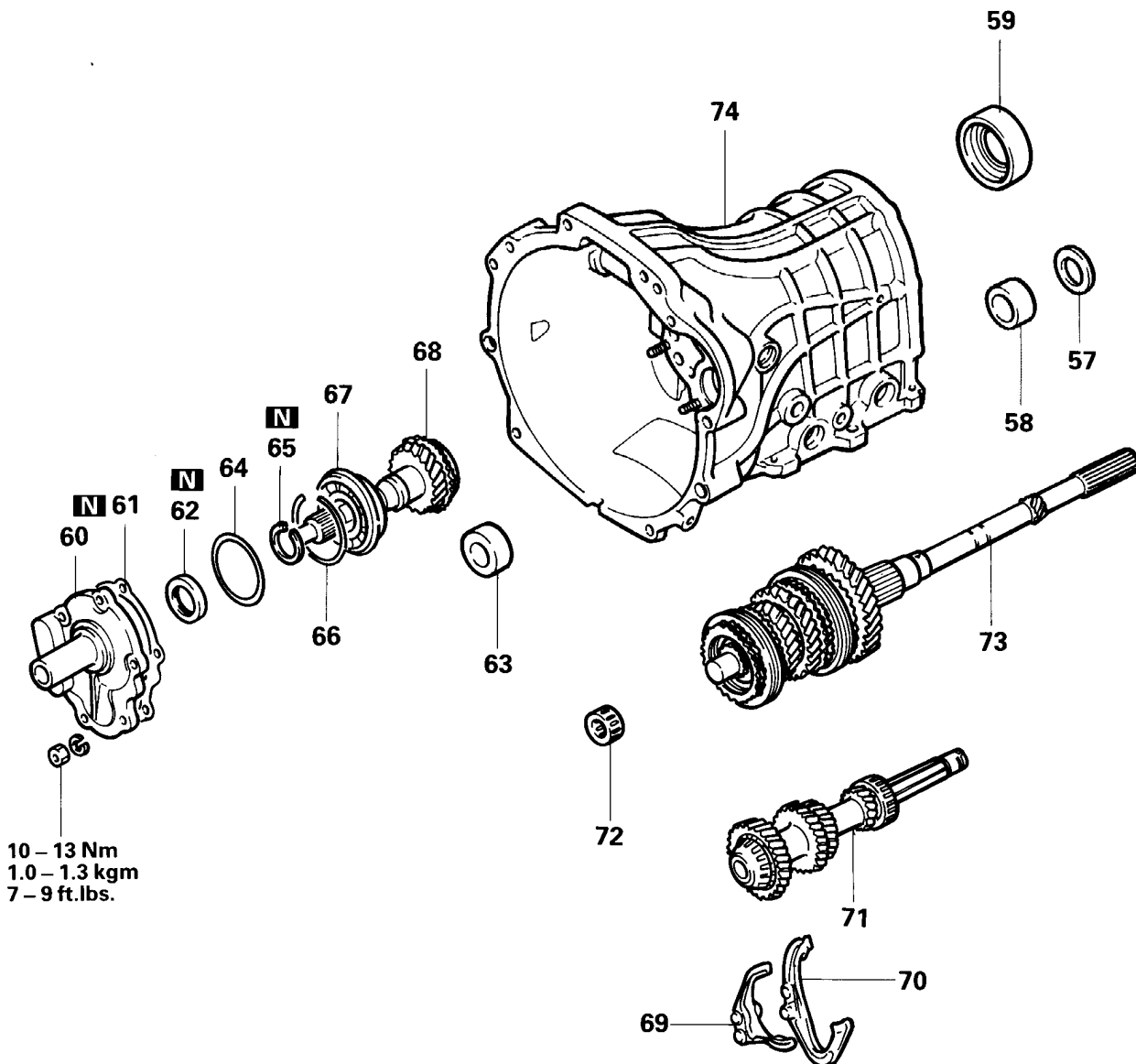

10 – 13 Nm
1.0 – 1.3 kgm
7 – 9 ft.lbs.

Disassembly steps

- J** 57. Spacer
- 58. Countershaft center bearing outer race
- 59. Mainshaft center bearing
- 60. Front bearing retainer
- G** 61. Front bearing retainer gasket
- E** 62. Oil seal
- 63. Countershaft front bearing outer race
- F** 64. Spacer
- C** 65. Snap ring
- 66. Snap ring
- K** **B** 67. Maindrive gear bearing
- 68. Maindrive gear
- 69. 3rd – 4th speed shift fork
- 70. 1st – 2nd speed shift fork
- 71. Countershaft assembly
- 72. Mainshaft front bearing
- 73. Mainshaft assembly
- 74. Transmission case

R5M21-2-B, D (KM135-5)

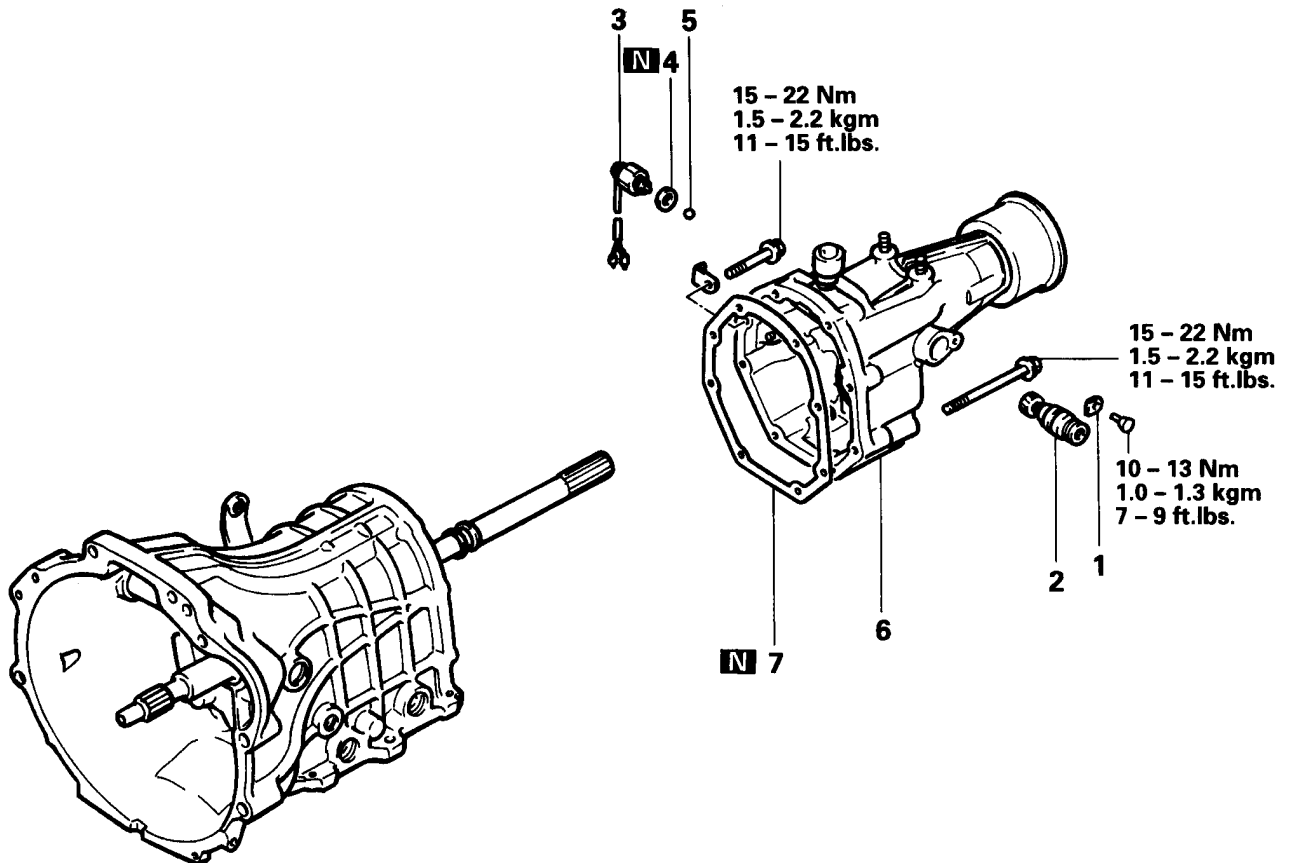
**Disassembly steps**

- 1. Lock plate
- f** 2. Speedometer gear
- 3. Backup lamp switch
- 4. Gasket
- 5. Steel ball
- 6. Extension housing
- h** 7. Extension housing gasket

R5M21-2-B, D (KM135-5)

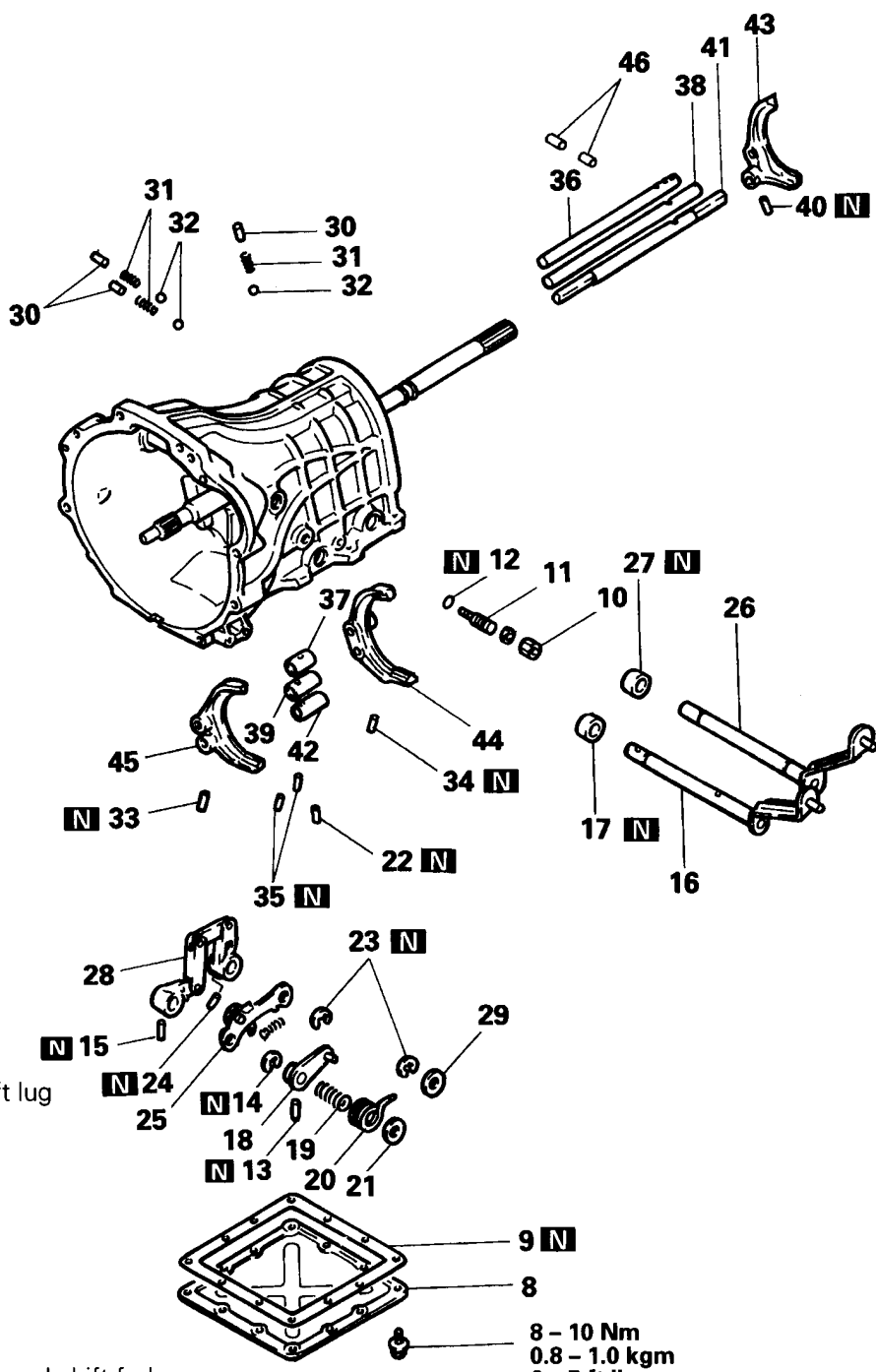

Disassembly steps

- 8. Under cover
- 9. Under cover gasket
- 10. Nut
- w** 11. Select adjuster
- N** 12. O-ring
- M** 13. Spring pin
- e** 14. Snap ring
- n** 15. Spring pin
- N** 16. Select shaft
- d** 17. Oil seal
- 18. Adjust arm
- 19. Distance spring
- 20. Return spring
- 21. Spacer
- o** 22. Spring pin for OD-R shift lug
- a** 23. Snap ring
- m** 24. Look pin
- P** 25. Stopper bracket
- 26. Shift shaft
- 27. Oil seal
- 28. Control rink
- 29. Spacer
- b** 30. Poppet plug
- b** 31. Poppet spring
- b** 32. Steel ball
- C** 33. Spring pin for 3rd-4th speed shift fork
- C** 34. Spring pin for 1st-2nd speed shift fork
- Z** 35. Spring pin for 3rd-4th speed shift lug and 1st-2nd speed shift lug
- 36. 1st-2nd speed shift rail
- 37. 1st-2nd speed shift lug
- 38. 3rd-4th speed shift rail
- 39. 3rd-4th speed shift lug
- D** 40. Spring pin for OD-R shift fork
- 41. OD-R shift rail
- 42. OD-R shift lug
- 43. OD-R shift fork
- 44. 1st-2nd speed shift fork
- 45. 3rd-4th speed shift fork
- 46. Interlock plunger

8 - 10 Nm
0.8 - 1.0 kgm
6 - 7 ft.lbs.

R5M21-2-B, D (KM135-5)

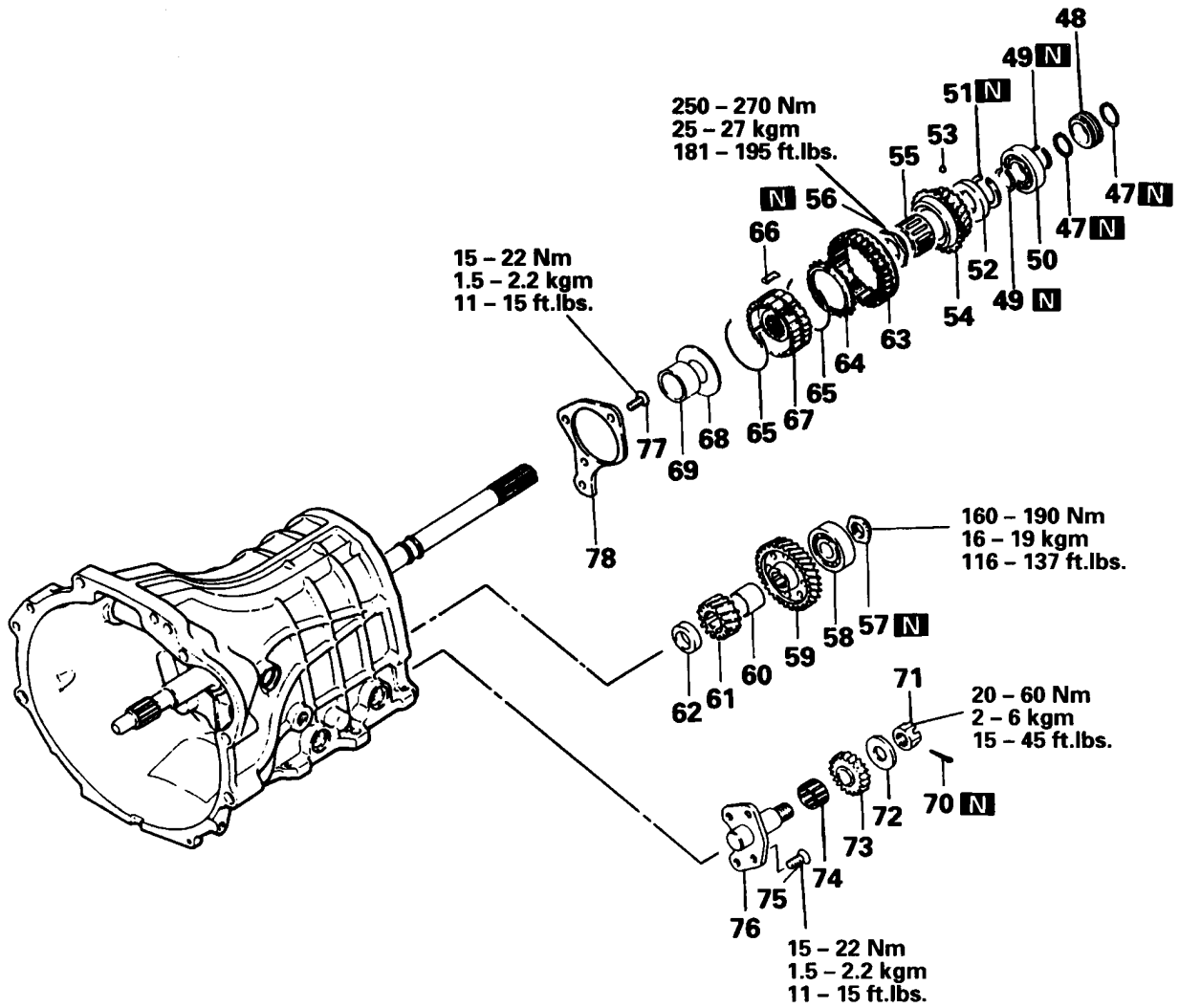

Disassembly steps

- 47. Snap ring
- 48. Speedometer drive gear
- P** 49. Snap ring
- P** 50. Mainshaft rear bearing
- 51. Snap ring
- 52. Spacer
- 53. Steel ball
- 54. Overdrive gear
- E** **S** 55. Needle bearing
- V** 56. Mainshaft lock nut
- U** 57. Countershaft lock nut
- 58. Countershaft rear bearing
- 59. Counter overdrive gear
- 60. Spacer
- 61. Counter reverse gear
- 62. Spacer
- O** 63. OD-R synchronizer sleeve
- Q** 64. Overdrive synchronizer ring
- P** 65. OD-R synchronizer spring
- P** 66. OD-R synchronizer key
- O** 67. OD-R synchronizer hub
- 68. Stopper plate
- 69. Spacer
- 70. Split pin
- 71. Slotted nut
- 72. Thrust washer
- 73. Reverse idler gear
- 74. Needle bearing
- M** 75. Bolt
- G** **L** 76. Reverse idler gear shaft
- K** 77. Bolt
- 78. Rear bearing retainer

R5M21-2-B, D (KM135-5)

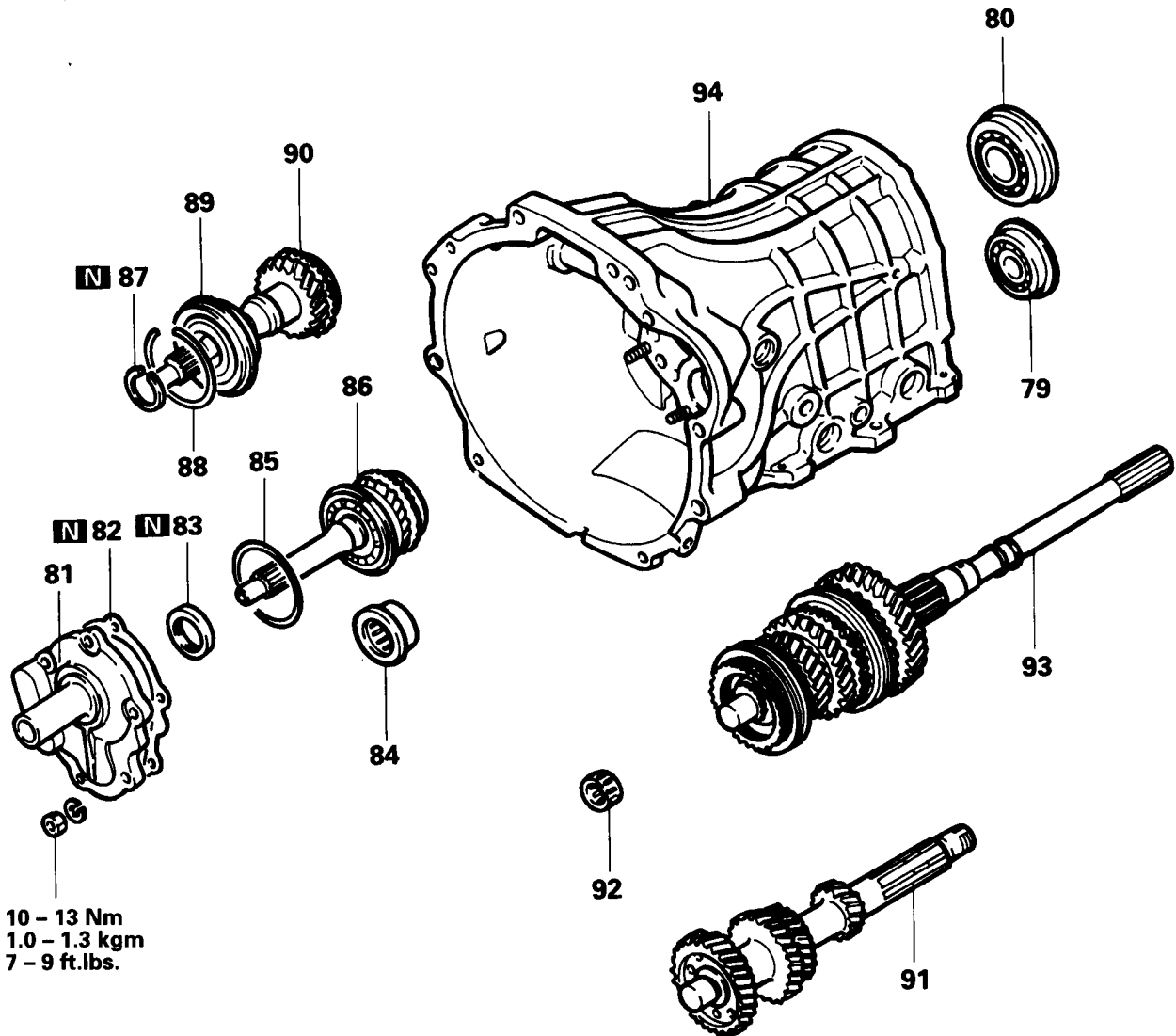

10 - 13 Nm
1.0 - 1.3 kgm
7 - 9 ft.lbs.

Disassembly steps

- Ⓜ I 79. Countershaft center bearing
- Ⓜ H 80. Mainshaft center bearing
- 81. Front bearing retainer
- G 82. Front bearing retainer gasket
- E 83. Oil seal
- Ⓜ D 84. Countershaft front bearing
- F 85. Spacer
- C 86. Maindrive gear assembly – Up to 1989
- 87. Snap ring
- 88. Snap ring
- Ⓜ B 89. Maindrive gear bearing } From 1990
- 90. Maindrive gear
- 91. Countershaft
- 92. Mainshaft front bearing
- 93. Mainshaft assembly
- 94. Transmission case

R5M21-2-P (KM135-8), R5M21-3-P

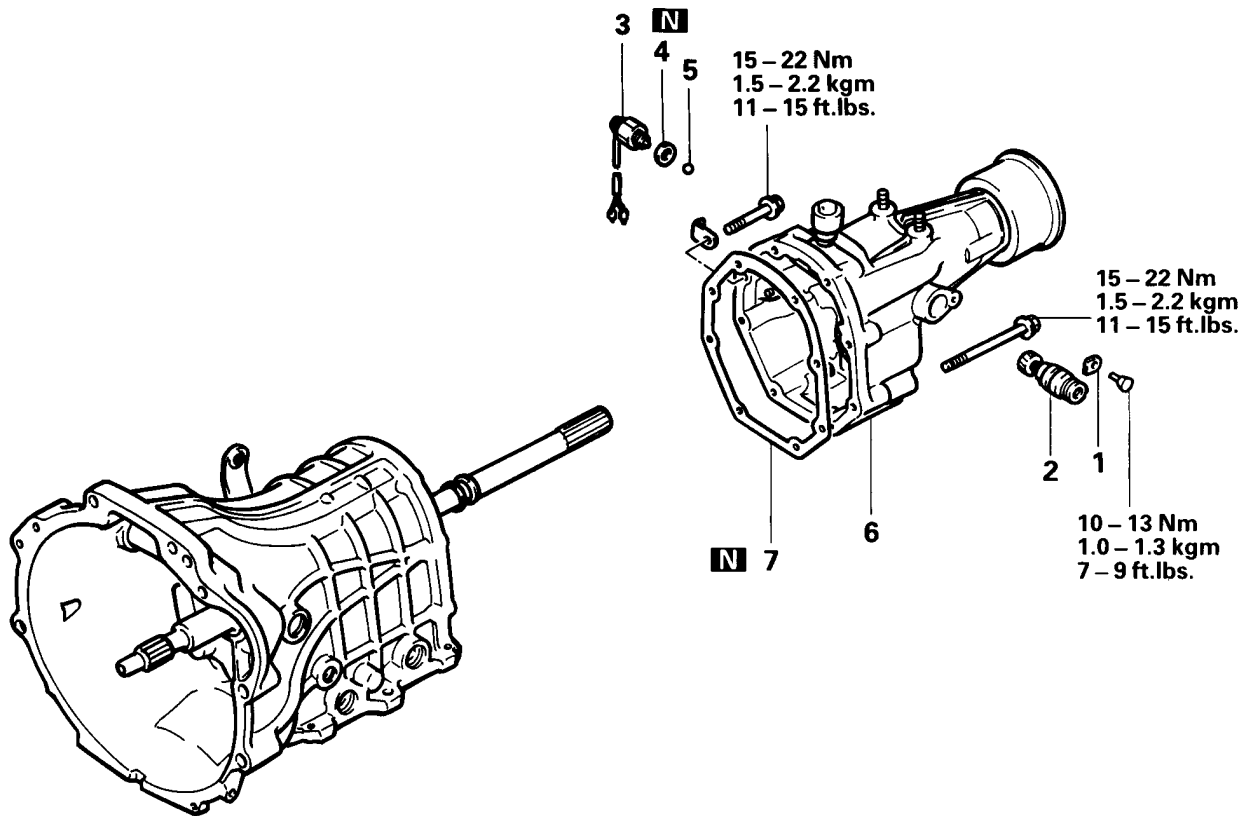
**Disassembly steps**

- 1. Lock plate
- f** 2. Speedometer gear
- 3. Backup lamp switch
- 4. Gasket
- 5. Steel ball
- 6. Extension housing
- h** 7. Extension housing gasket

R5M21-2-P (KM135-8), R5M21-3-P

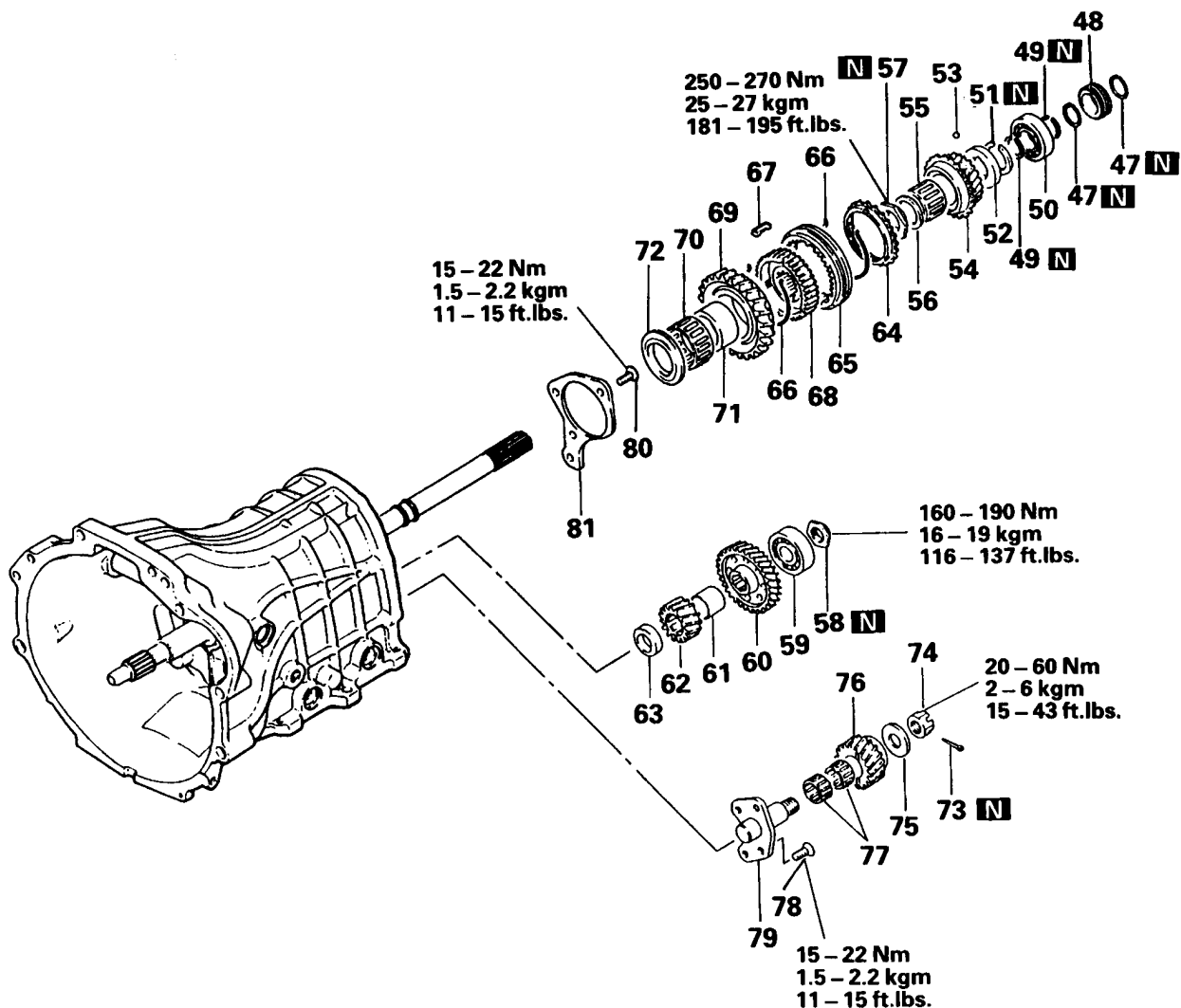

Disassembly steps

- | | | | |
|-------------------|---------------------------------|--|--|
| | 47. Snap ring | | 65. OD-R synchronizer sleeve |
| | 48. Speedometer drive gear | | 66. OD-R synchronizer spring |
| P | 49. Snap ring | | 67. OD-R synchronizer key |
| P | 50. Mainshaft rear bearing | | 68. OD-R synchronizer hub |
| | 51. Snap ring | | 69. Reverse gear |
| | 52. Spacer | | 70. Needle bearing |
| | 53. Steel ball | | N 71. Bearing sleeve |
| | 54. Overdrive gear | | 72. Spacer |
| | 55. Needle bearing | | 73. Split pin |
| | 56. Bearing spacer | | 74. Slotted nut |
| F S | 57. Mainshaft lock nut | | 75. Thrust washer |
| V | 58. Countershaft lock nut | | 76. Reverse idler gear |
| U | 59. Countershaft rear bearing | | 77. Needle bearing |
| | 60. Counter overdrive gear | | M 78. Bolt |
| | 61. Spacer | | G L 79. Reverse idler gear shaft |
| | 62. Counter reverse gear | | K 80. Bolt |
| | 63. Spacer | | 81. Rear bearing retainer |
| Q | 64. Overdrive synchronizer ring | | |

R5M21-2-P (KM135-8), R5M21-3-P

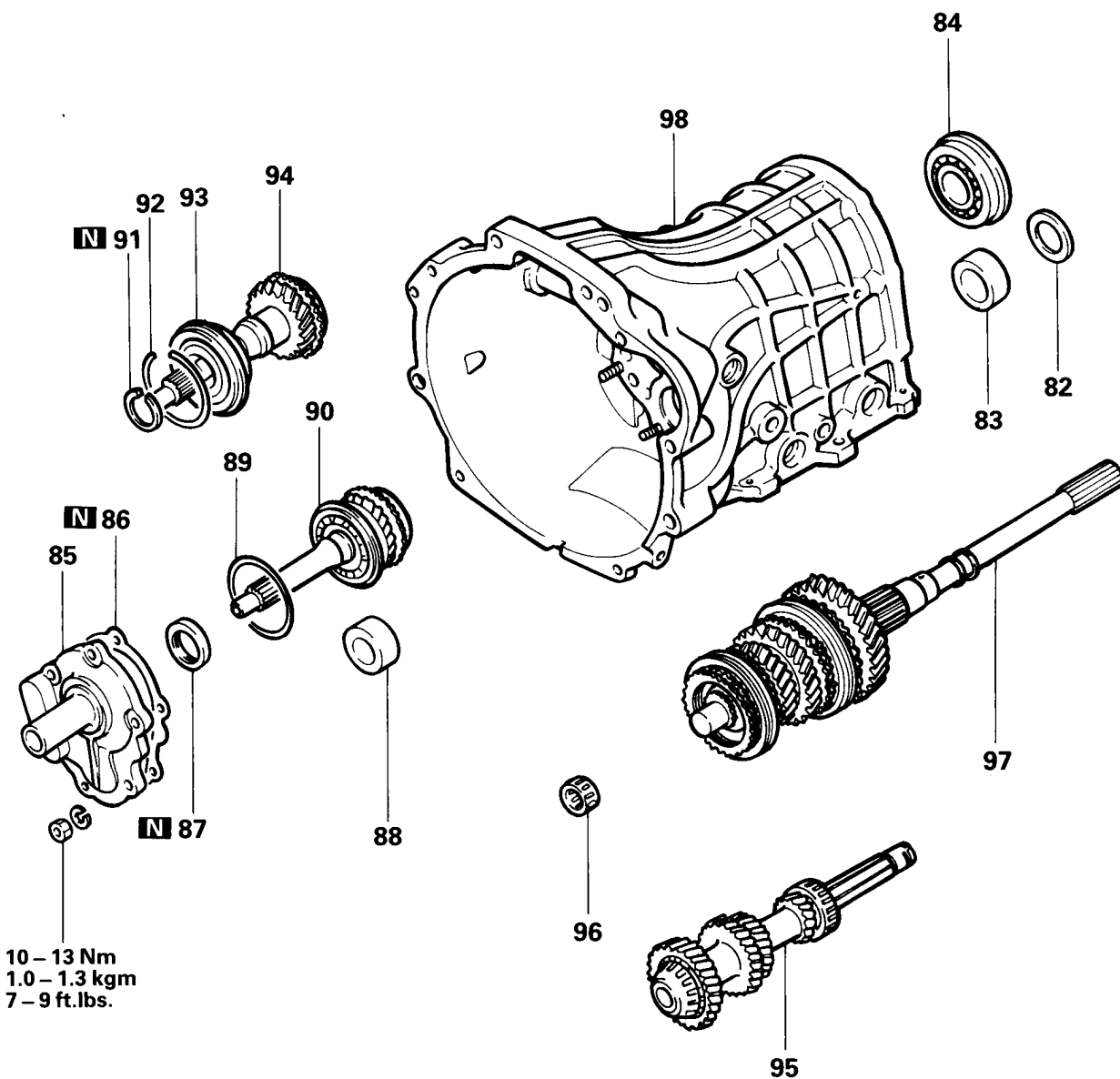

10 – 13 Nm
1.0 – 1.3 kgm
7 – 9 ft.lbs.

Disassembly steps

- J** 82. Spacer
- 83. Countershaft center bearing outer race
- ① **H** 84. Mainshaft center bearing
- 85. Front bearing retainer
- G** 86. Front bearing retainer gasket
- E** 87. Oil seal
- 88. Countershaft front bearing outer race
- F** 89. Spacer
- 90. Maindrive gear assembly – Up to 1989
- C** 91. Snap ring
- 92. Snap ring
- ② **B** 93. Maindrive gear bearing } From 1990
- 94. Maindrive gear
- ③ **A** 95. Countershaft assembly
- 96. Mainshaft front bearing
- 97. Mainshaft assembly
- 98. Transmission case

R5M21-2-C, E (KM135-1, 9), R5M21-8-E

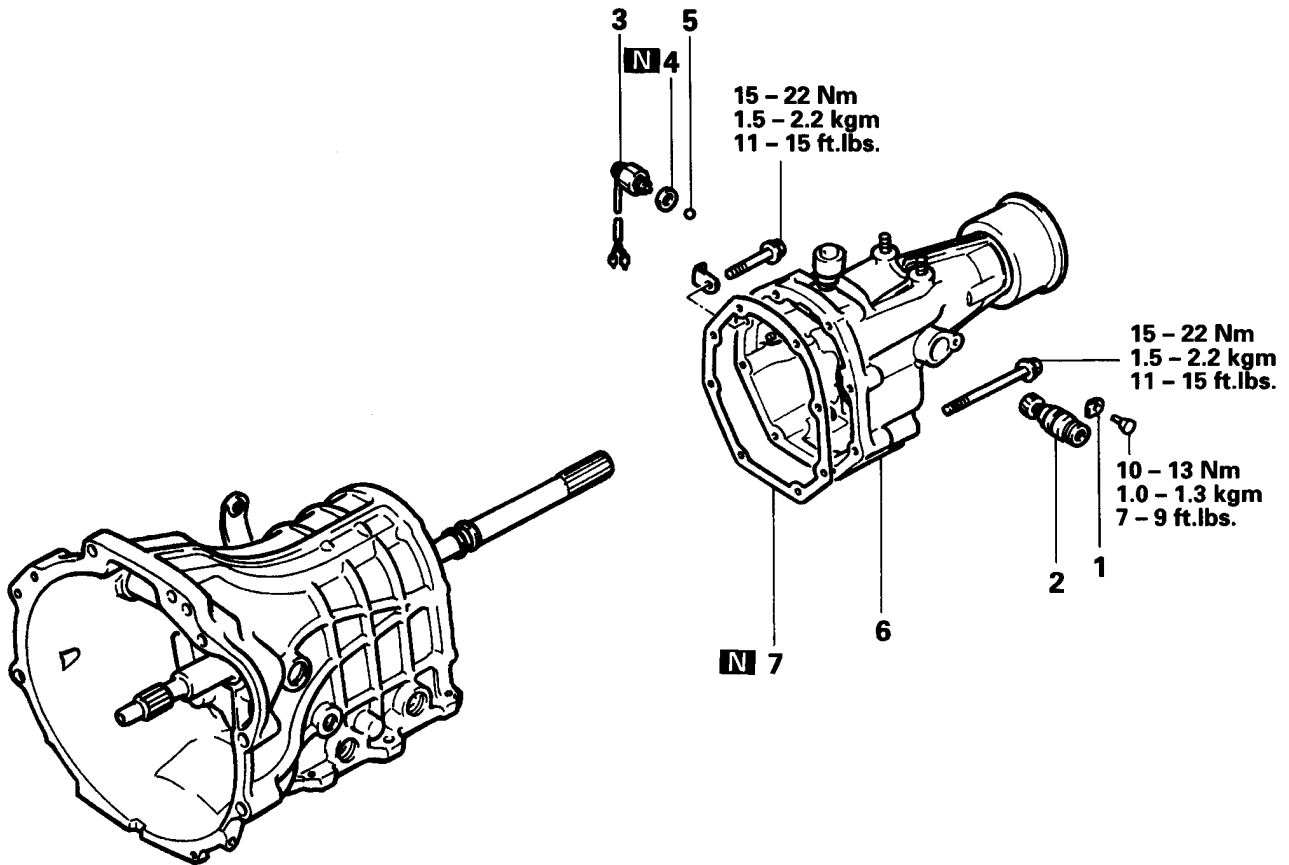
**Disassembly steps**

- 1. Lock plate
- f** 2. Speedometer gear
- 3. Backup lamp switch
- 4. Gasket
- 5. Steel ball
- 6. Extension housing
- h** 7. Extension housing gasket

R5M21-2-C, E (KM135-1, 9), R5M21-8-E

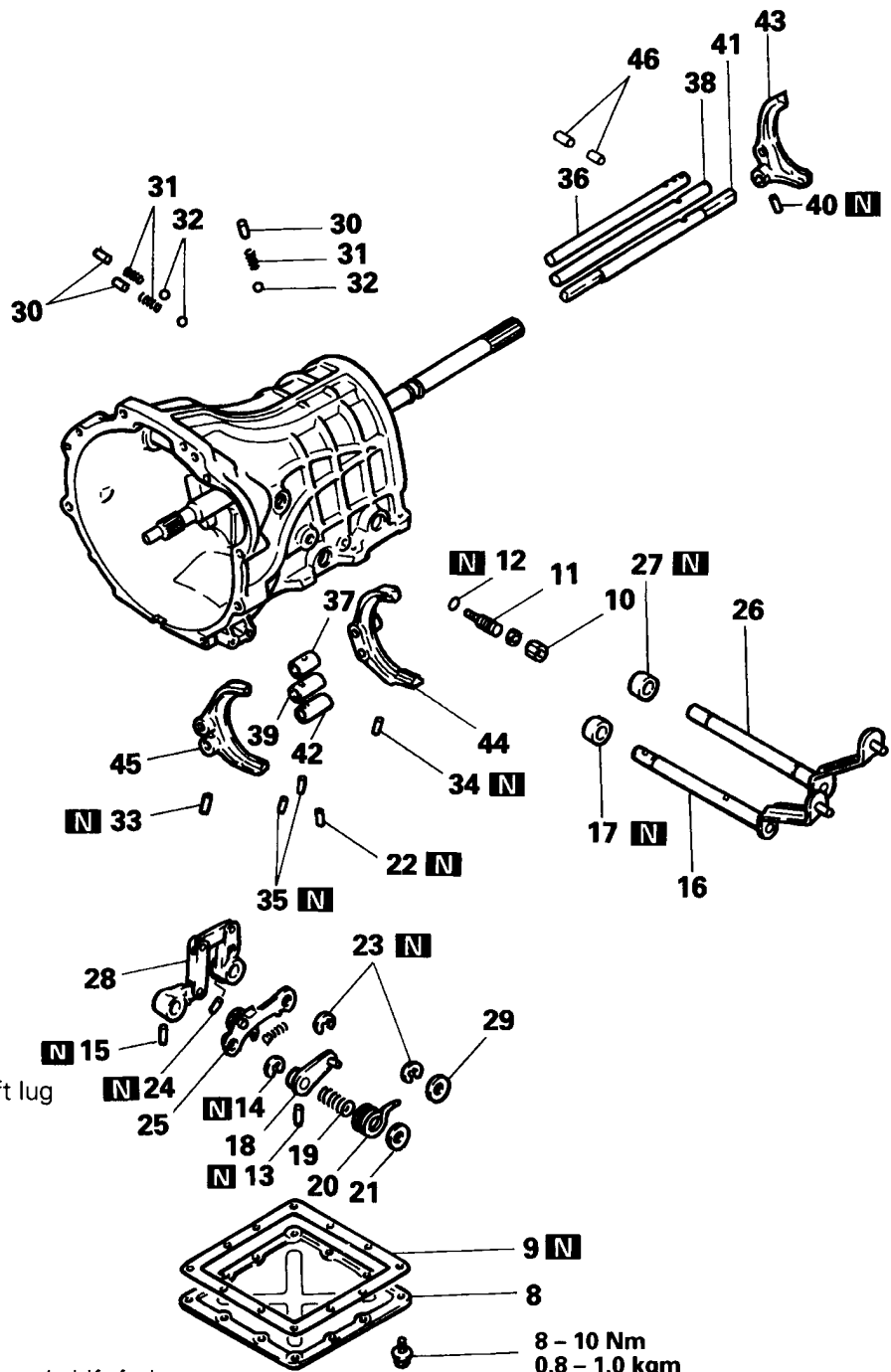

Disassembly steps

- 8. Under cover
- 9. Under cover gasket
- 10. Nut
- W 11. Select adjuster
- 12. O-ring
- M e 13. Spring pin
- n 14. Snap ring
- N d 15. Spring pin
- 16. Select shaft
- 17. Oil seal
- 18. Adjust arm
- 19. Distance spring
- 20. Return spring
- 21. Spacer
- C a 22. Spring pin for OD-R shift lug
- m 23. Snap ring
- P c 24. Lock pin
- 25. Stopper bracket
- 26. Shift shaft
- 27. Oil seal
- 28. Control link
- 29. Spacer
- b 30. Poppet plug
- b 31. Poppet spring
- 32. Steel ball
- C Y 33. Spring pin for 3rd-4th speed shift fork
- C Y 34. Spring pin for 1st-2nd speed shift fork
- C Z 35. Spring pin for 3rd-4th speed shift lug and 1st-2nd speed shift lug
- 36. 1st-2nd speed shift rail
- 37. 1st-2nd speed shift lug
- 38. 3rd-4th speed shift rail
- 39. 3rd-4th speed shift lug
- D X 40. Spring pin for OD-R shift fork
- 41. OD-R shift rail
- 42. OD-R shift lug
- 43. OD-R shift fork
- 44. 1st-2nd speed shift fork
- 45. 3rd-4th speed shift fork
- 46. Interlock plunger

8 - 10 Nm
0.8 - 1.0 kgm
6 - 7 ft.lbs.

R5M21-2-C, E (KM135-1, 9), R5M21-8-E

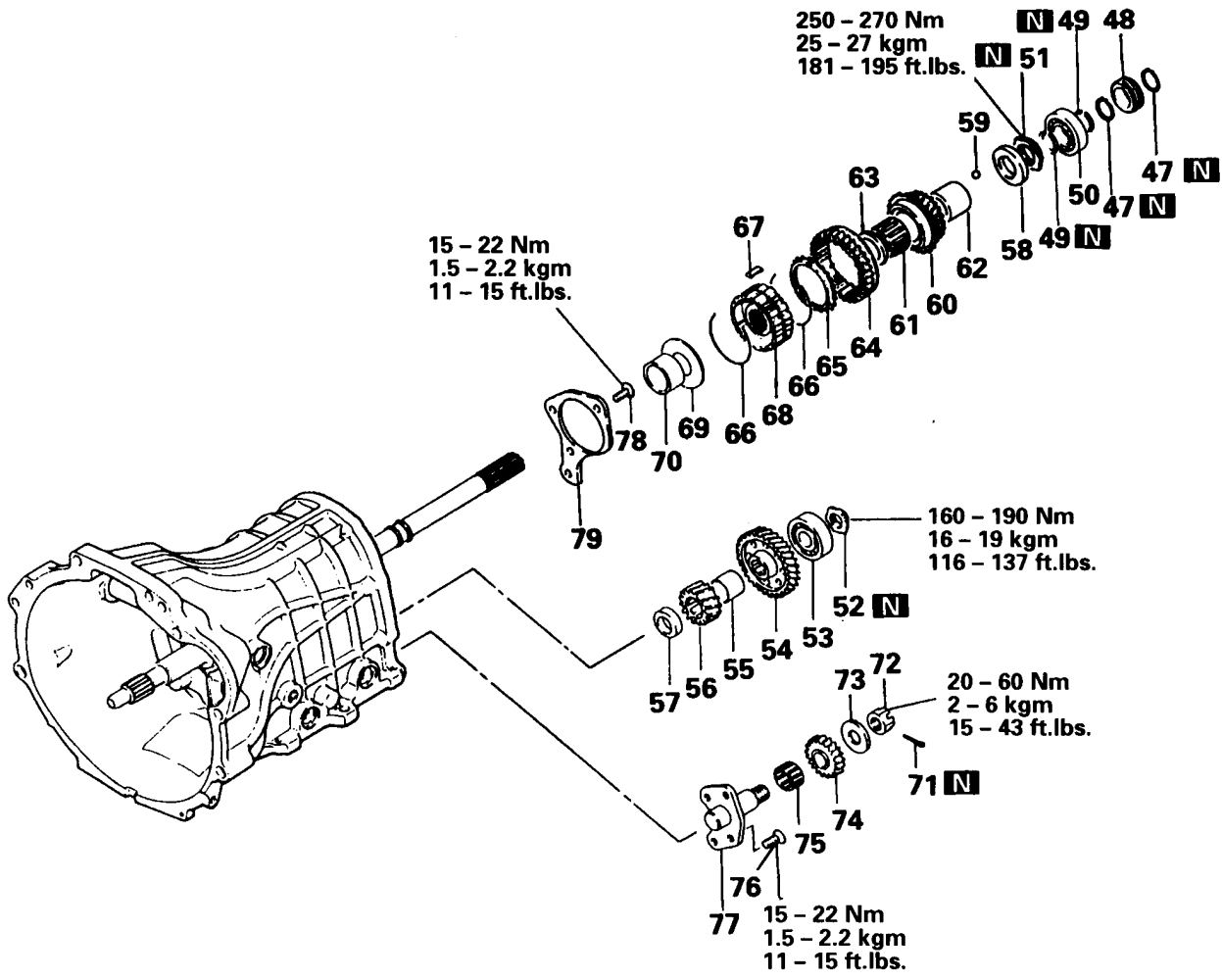

Disassembly steps

- 47. Snap ring
- 48. Speedometer drive gear
- P** 49. Snap ring
- P** 50. Mainshaft rear bearing
- E** **S** 51. Mainshaft lock nut
- V** 52. Countershaft lock nut
- U** 53. Countershaft rear bearing
- 54. Counter overdrive gear
- 55. Spacer
- 56. Counter reverse gear
- 57. Spacer
- 58. Spacer
- 59. Steel ball
- 60. Overdrive gear
- 61. Needle bearing
- F** **R** 62. Bearing sleeve
- 63. Bearing spacer

- O** 64. OD-R synchronizer sleeve
- O** 65. Overdrive synchronizer ring
- P** 66. OD-R synchronizer spring
- P** 67. OD-R synchronizer key
- O** 68. OD-R synchronizer hub
- 69. Stopper plate
- 70. Spacer
- 71. Split pin
- 72. Slotted nut
- 73. Thrust washer
- 74. Reverse idler gear
- 75. Needle bearing
- M** 76. Bolt
- G** **L** 77. Reverse idler gear shaft
- K** 78. Bolt
- 79. Rear bearing retainer

R5M21-2-C, E (KM135-1, 9), R5M21-8-E

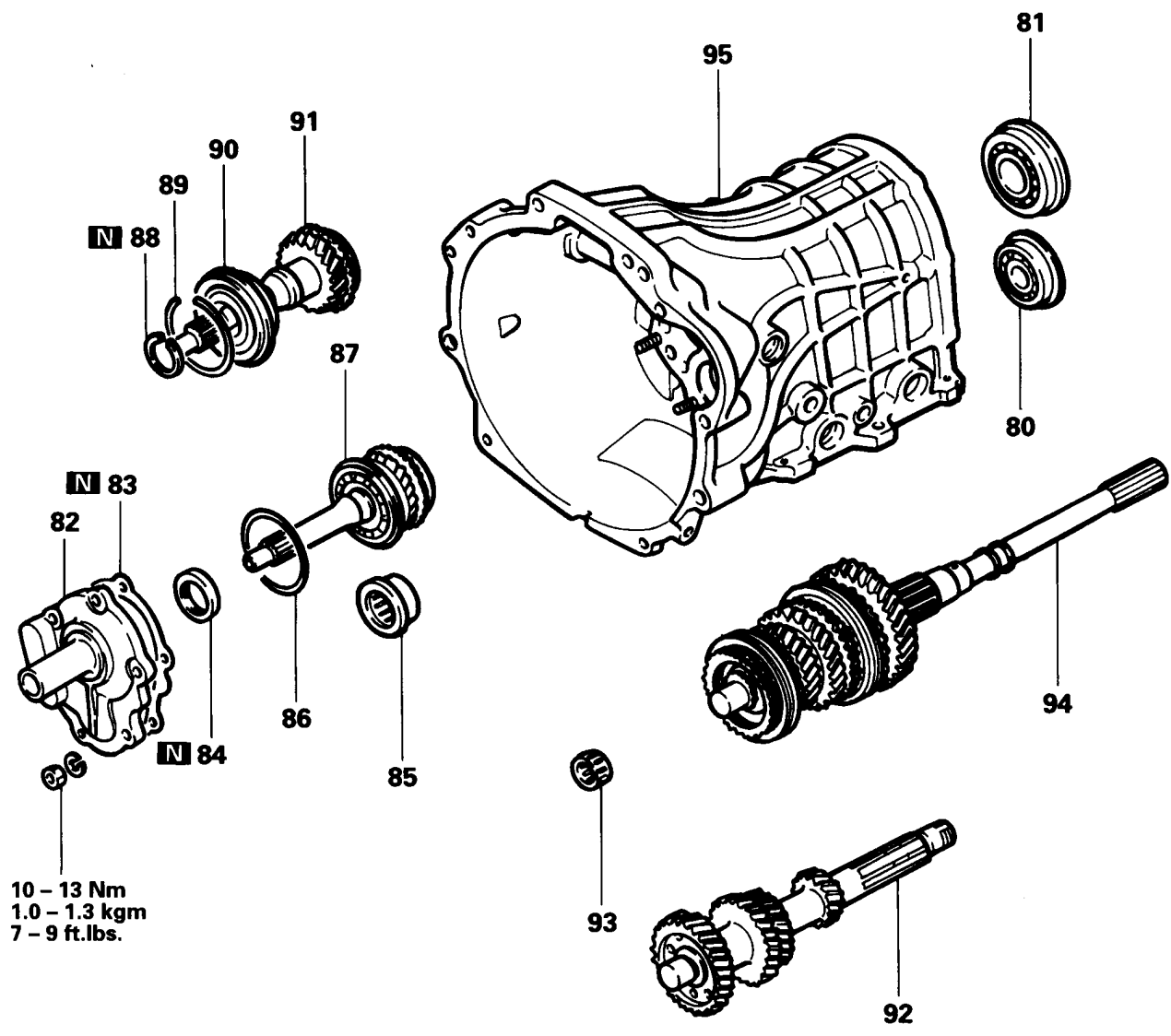

10 – 13 Nm
 1.0 – 1.3 kgm
 7 – 9 ft.lbs.

Disassembly steps

- (H) (I) 80. Countershaft center bearing
- (I) (H) 81. Mainshaft center bearing
- 82. Front bearing retainer
- (G) 83. Front bearing retainer gasket
- (E) 84. Oil seal
- (J) (D) 85. Countershaft front bearing
- (F) 86. Spacer
- 87. Maindrive gear assembly – Up to 1989
- (C) 88. Snap ring
- 89. Snap ring
- (K) (B) 90. Maindrive gear bearing } From 1990
- 91. Maindrive gear
- 92. Countershaft
- 93. Mainshaft front bearing
- 94. Mainshaft assembly
- 95. Transmission case

R5M21-2-G, Q (KM135-B), R5M21-8-Q

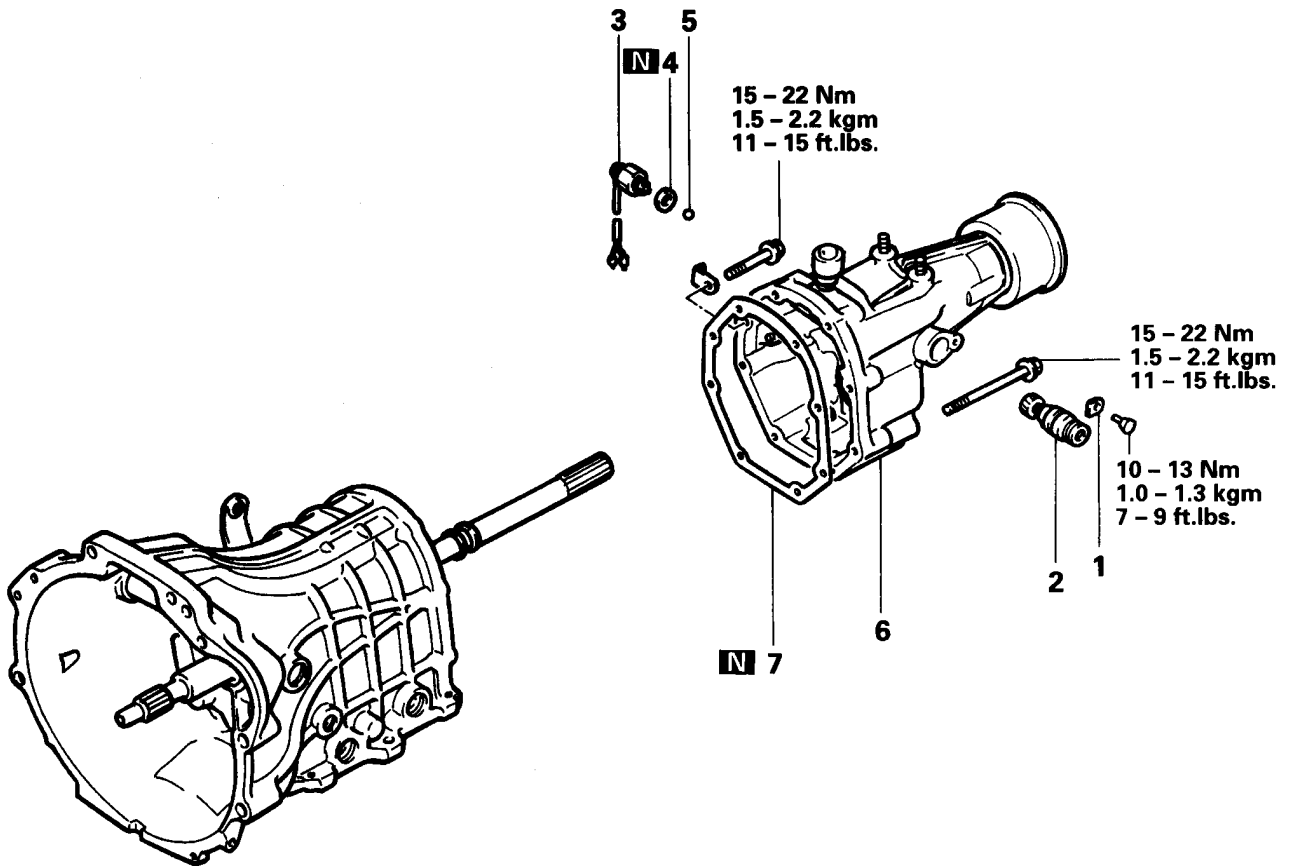
**Disassembly steps**

- 1. Lock plate
- [f] 2. Speedometer gear
- 3. Backup lamp switch
- 4. Gasket
- 5. Steel ball
- 6. Extension housing
- [h] 7. Extension housing gasket

R5M21-2-G, Q (KM135-B), R5M21-8-Q

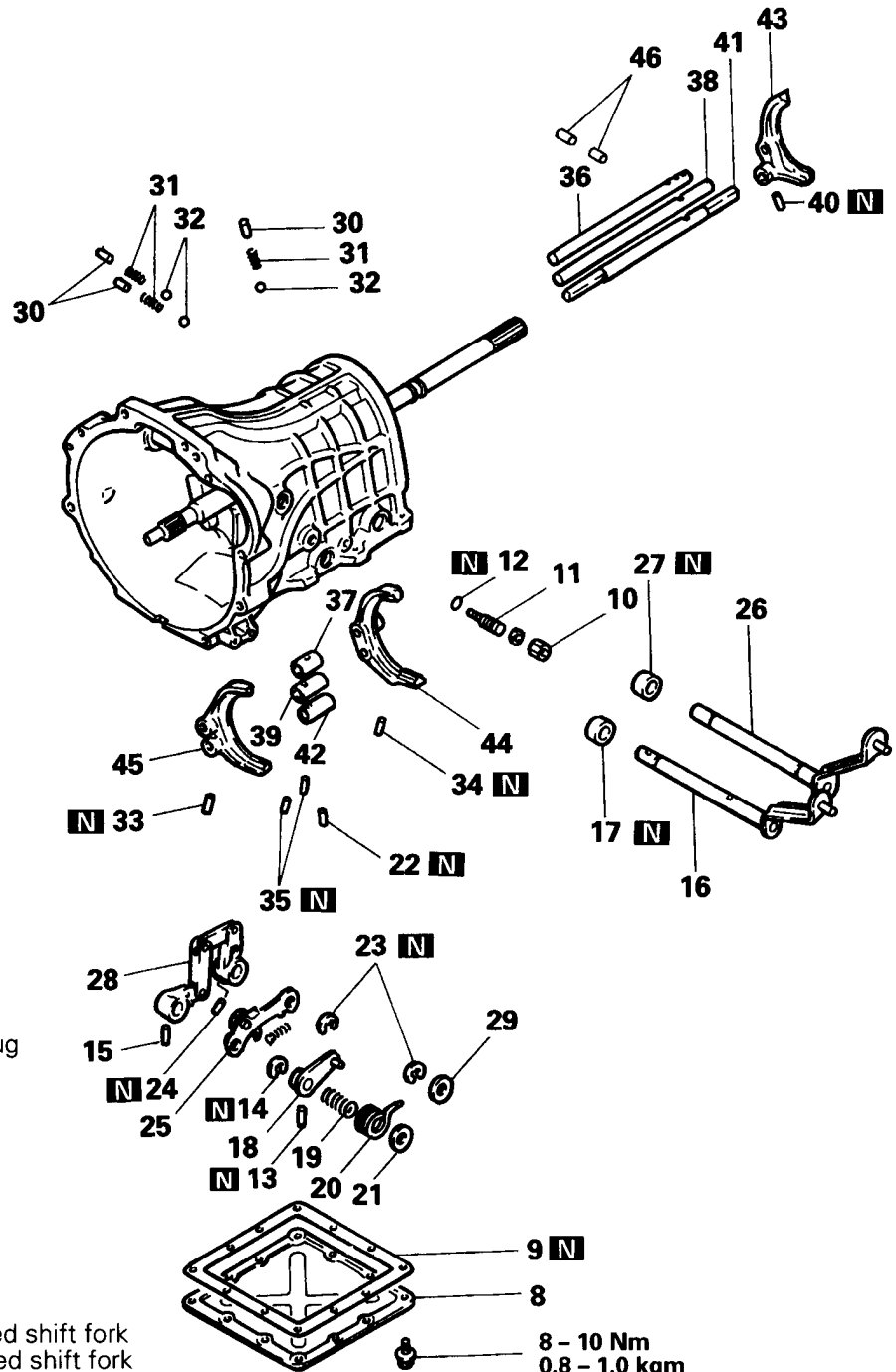

Disassembly steps

- 8. Under cover
- 9. Under cover gasket
- 10. Nut
- W 11. Select adjuster
- 12. O-ring
- M e 13. Spring pin
- n 14. Snap ring
- N d 15. Spring pin
- 16. Select shaft
- 17. Oil seal
- 18. Adjust arm
- 19. Distance spring
- 20. Return spring
- 21. Spacer
- C a 22. Spring pin for OD-R shift lug
- m 23. Snap ring
- P c 24. Lock pin
- 25. Stopper bracket
- 26. Shift shaft
- 27. Oil seal
- 28. Control link
- 29. Spacer
- 30. Poppet plug
- b 31. Poppet spring
- b 32. Steel ball
- C Y 33. Spring pin for 3rd-4th speed shift fork
- C Y 34. Spring pin for 1st-2nd speed shift fork
- Q Z 35. Spring pin for 3rd-4th speed shift lug and 1st-2nd speed shift lug
- 36. 1st-2nd speed shift rail
- 37. 1st-2nd speed shift lug
- 38. 3rd-4th speed shift rail
- 39. 3rd-4th speed shift lug
- D X 40. Spring pin for OD-R shift fork
- 41. OD-R shift rail
- 42. OD-R shift lug
- 43. OD-R shift fork
- 44. 1st-2nd speed shift fork
- 45. 3rd-4th speed shift fork
- 46. Interlock plunger

8 - 10 Nm
0.8 - 1.0 kgm
6 - 7 ft.lbs.

R5M21-2-G, Q (KM135-B), R5M21-8-Q

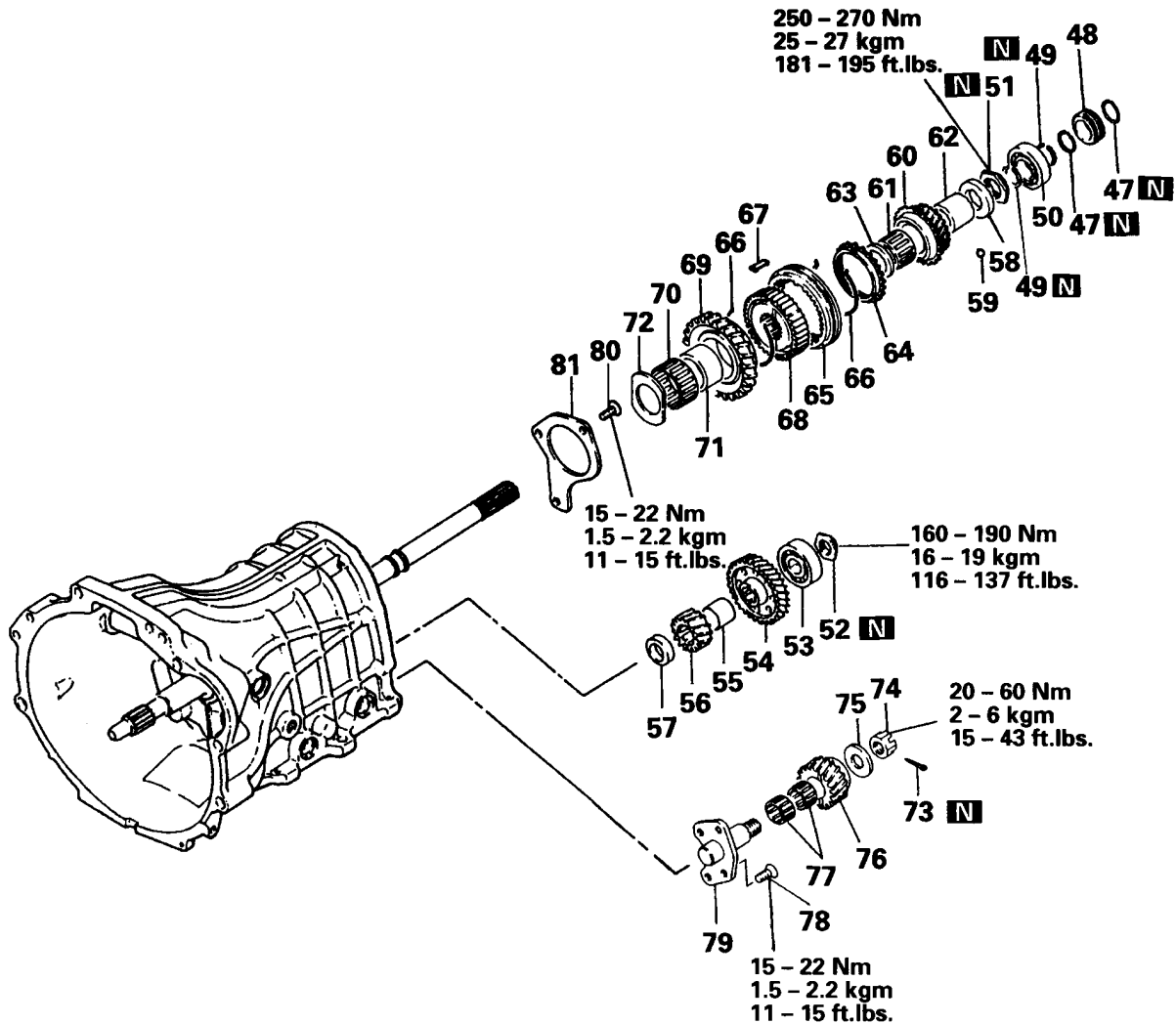

Disassembly steps

- 47. Snap ring
- 48. Speedometer drive gear
- P** 49. Snap ring
- P** 50. Mainshaft rear bearing
- E** **S** 51. Mainshaft lock nut
- V** 52. Countershaft lock nut
- U** 53. Countershaft rear bearing
- 54. Counter overdrive gear
- 55. Spacer
- 56. Counter reverse gear
- 57. Spacer
- 58. Spacer
- 59. Steel ball
- 60. Overdrive gear
- F** **R** 61. Needle bearing
- R** 62. Bearing sleeve
- Q** 63. Bearing spacer
- Q** 64. Overdrive synchronizer ring
- O** 65. OD-R synchronizer sleeve
- P** 66. OD-R synchronizer spring
- P** 67. OD-R synchronizer key
- O** 68. OD-R synchronizer hub
- 69. Reverse gear
- 70. Needle bearing
- N** 71. Bearing sleeve
- 72. Spacer
- 73. Split pin
- 74. Slotted nut
- 75. Thrust washer
- 76. Reverse idler gear
- 77. Needle bearing
- M** 78. Bolt
- G** **L** 79. Reverse idler gear shaft
- K** 80. Bolt
- 81. Rear bearing retainer

R5M21-2-G, Q (KM135-B), R5M21-8-Q

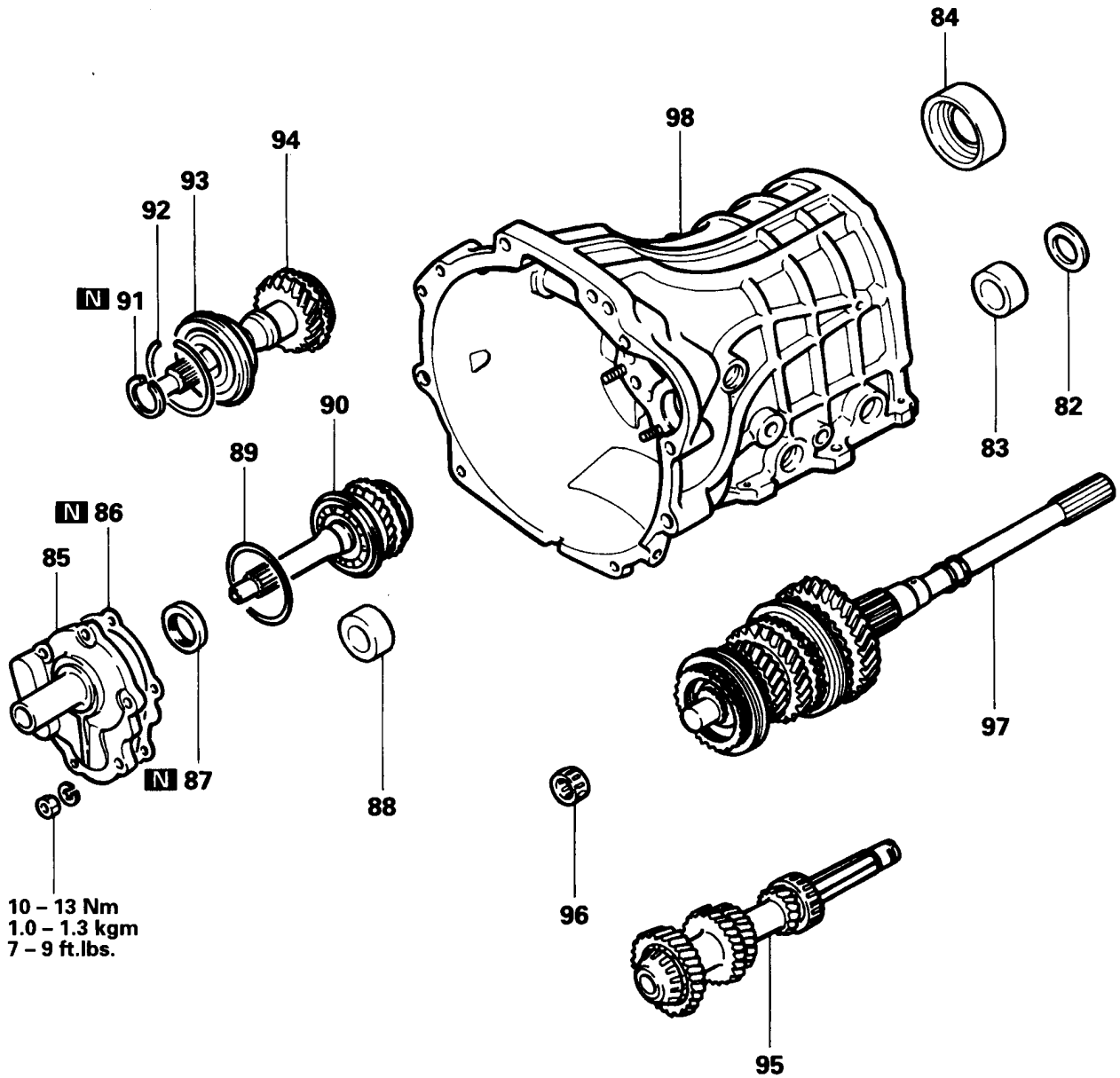

10 - 13 Nm
1.0 - 1.3 kgm
7 - 9 ft.lbs.

Disassembly steps

- [J] 82. Spacer
- 83. Countershaft bearing outer race
- 84. Mainshaft center bearing
- 85. Front bearing retainer
- [G] 86. Front bearing retainer gasket
- [E] 87. Oil seal
- 88. Countershaft front bearing outer race
- [F] 89. Spacer
- 90. Maindrive gear assembly – Up to 1989
- [C] 91. Snap ring
- 92. Snap ring
- [K] [B] 93. Maindrive gear bearing } From 1990
- 94. Maindrive gear
- [L] [A] 95. Countershaft assembly
- 96. Mainshaft front bearing
- 97. Mainshaft assembly
- 98. Transmission case

R5M21-3-C

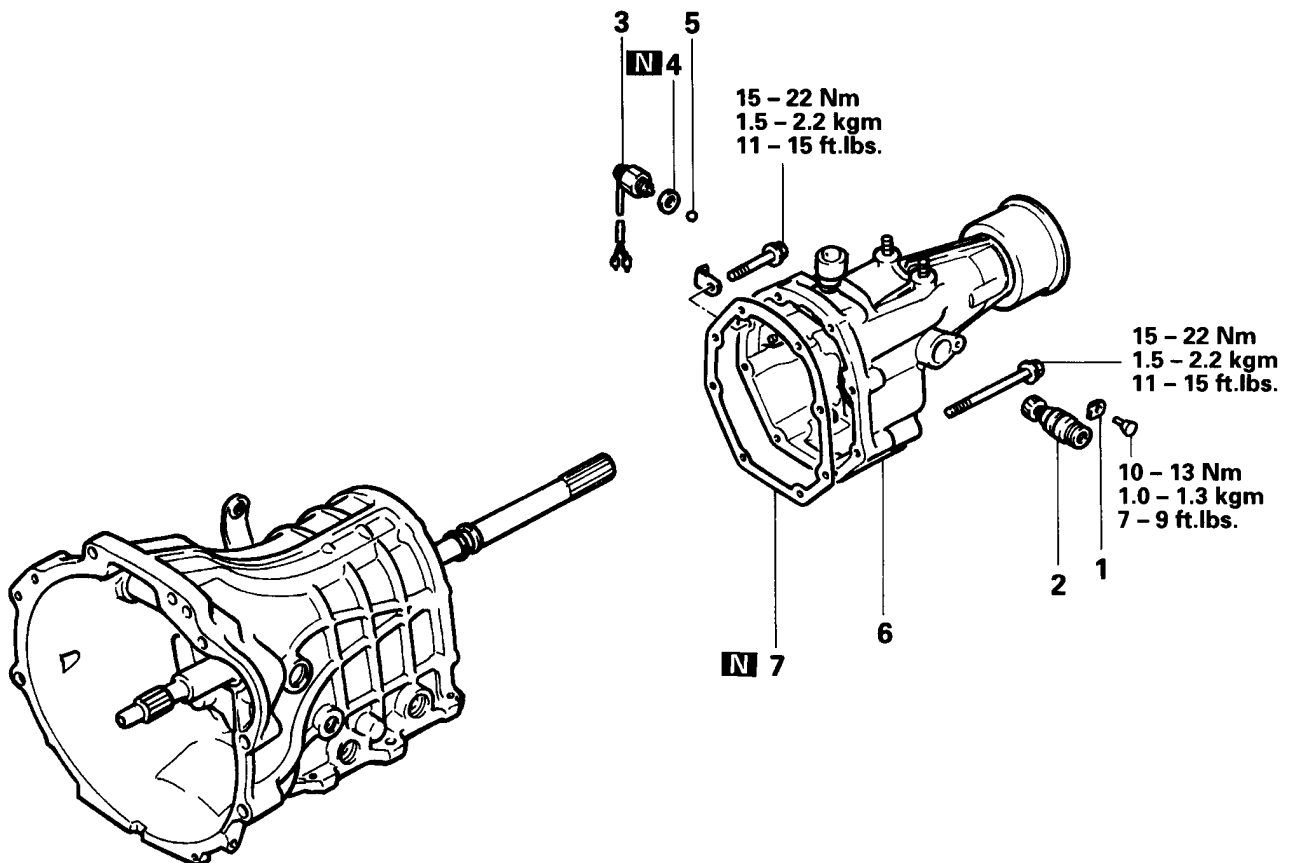
**Disassembly steps**

- 1. Lock plate
- f** 2. Speedometer gear
- 3. Backup lamp switch
- 4. Gasket
- 5. Steel ball
- 6. Extension housing
- h** 7. Extension housing gasket

R5M21-3-C

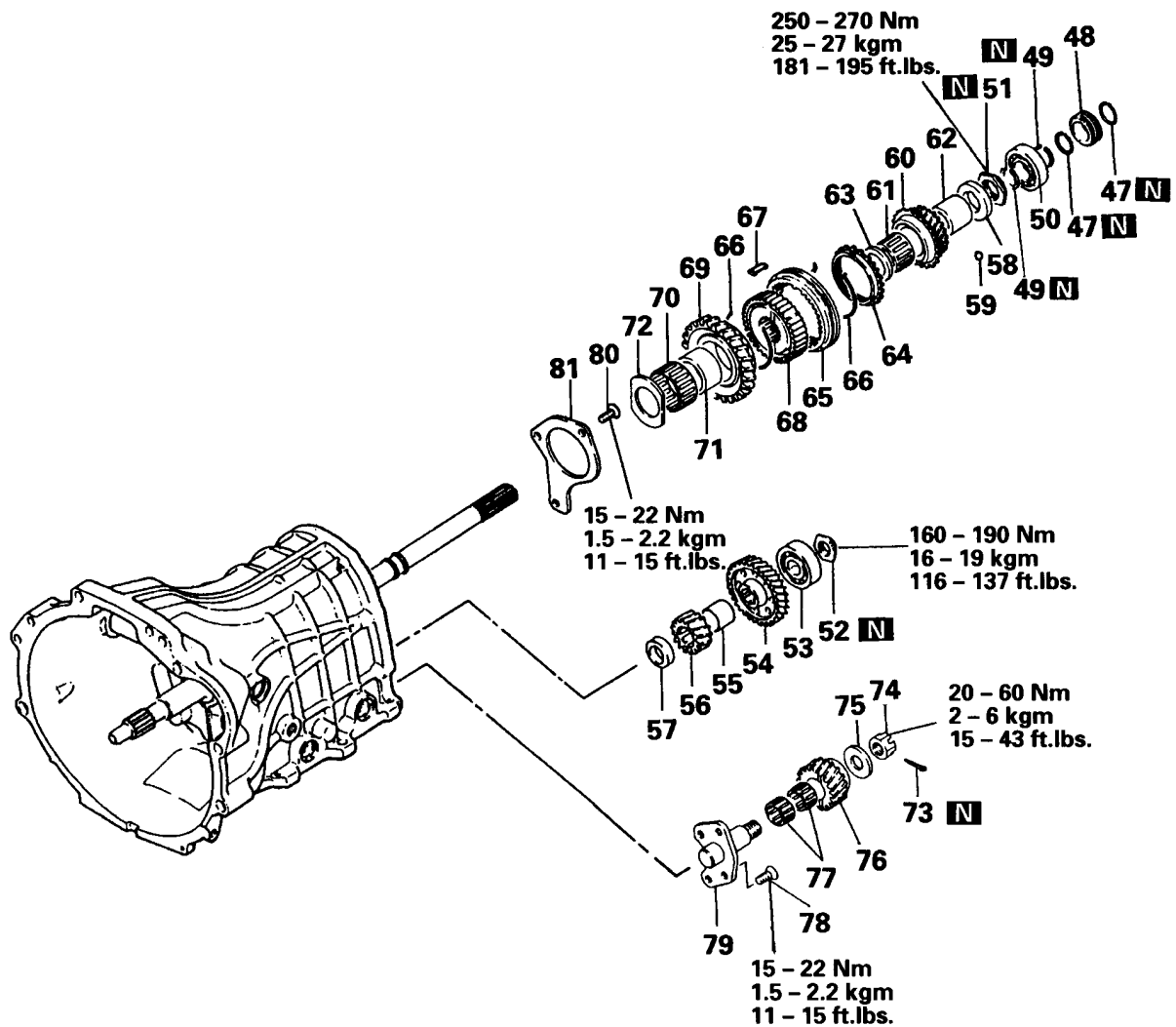

Disassembly steps

- 47. Snap ring
- 48. Speedometer drive gear
- P** 49. Snap ring
- P** 50. Mainshaft rear bearing
- E** **S** 51. Mainshaft lock nut
- V** 52. Countershaft lock nut
- U** 53. Countershaft rear bearing
- 54. Counter overdrive gear
- 55. Spacer
- 56. Counter reverse gear
- 57. Spacer
- 58. Spacer
- 59. Steel ball
- 60. Overdrive gear
- F** **R** 61. Needle bearing
- R** 62. Bearing sleeve
- Q** 63. Bearing spacer
- Q** 64. Overdrive synchronizer ring
- O** 65. OD-R synchronizer sleeve
- P** 66. OD-R synchronizer spring
- P** 67. OD-R synchronizer key
- O** 68. OD-R synchronizer hub
- 69. Reverse gear
- 70. Needle bearing
- N** 71. Bearing sleeve
- 72. Spacer
- 73. Split pin
- 74. Slotted nut
- 75. Thrust washer
- 76. Reverse idler gear
- 77. Needle bearing
- M** 78. Bolt
- G** **L** 79. Reverse idler gear shaft
- K** 80. Bolt
- 81. Rear bearing retainer

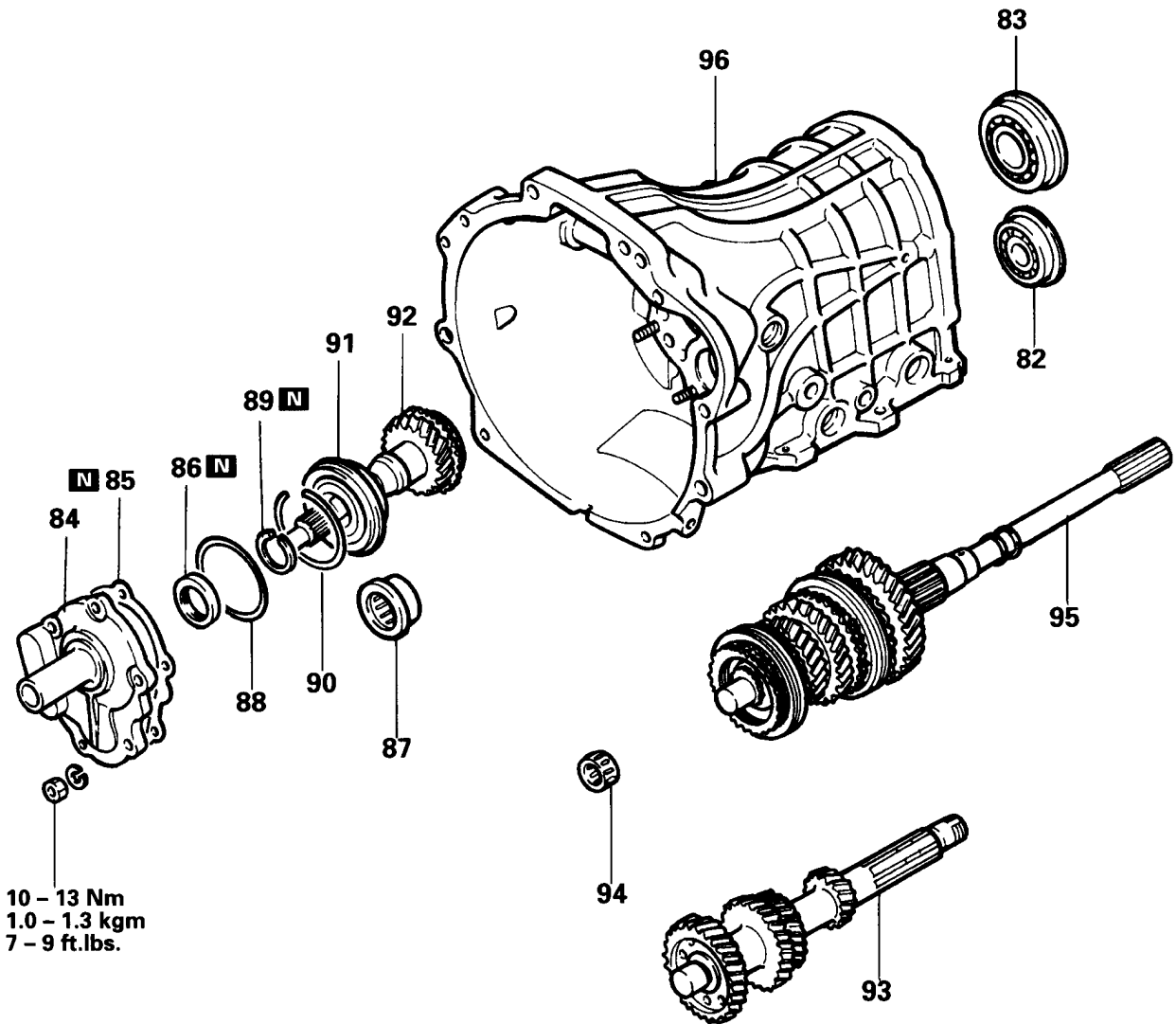

10 - 13 Nm
1.0 - 1.3 kgm
7 - 9 ft.lbs.

Disassembly steps

- (H) (I) 82. Countershaft center bearing
- (I) (H) 83. Mainshaft center bearing
- (A) 84. Front bearing retainer
- (G) 85. Front bearing retainer gasket
- (E) 86. Oil seal
- (J) (D) 87. Countershaft front bearing
- (F) 88. Spacer
- (C) 89. Snap ring

- (K) (B) 90. Snap ring
- (K) (B) 91. Maindrive gear bearing
- (K) (B) 92. Maindrive gear
- (K) (B) 93. Countershaft
- (K) (B) 94. Mainshaft front bearing
- (K) (B) 95. Mainshaft assembly
- (K) (B) 96. Transmission case

R5M21-7-E

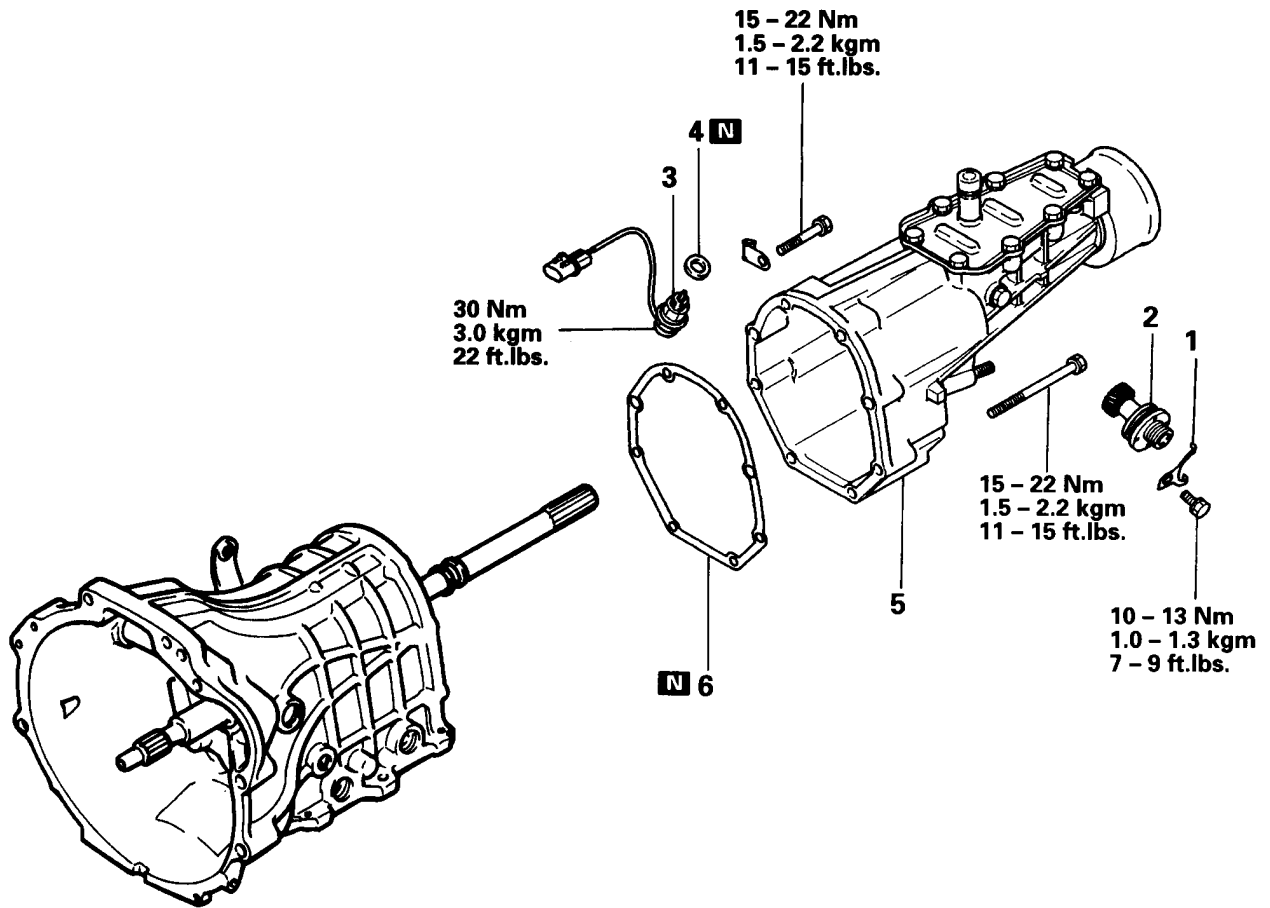
**Disassembly steps**

- 1. Stopper plate
- g 2. Speedometer gear
- 3. Backup lamp switch
- 4. Gasket
- 5. Extension housing
- h 6. Extension housing gasket

R5M21-7-E

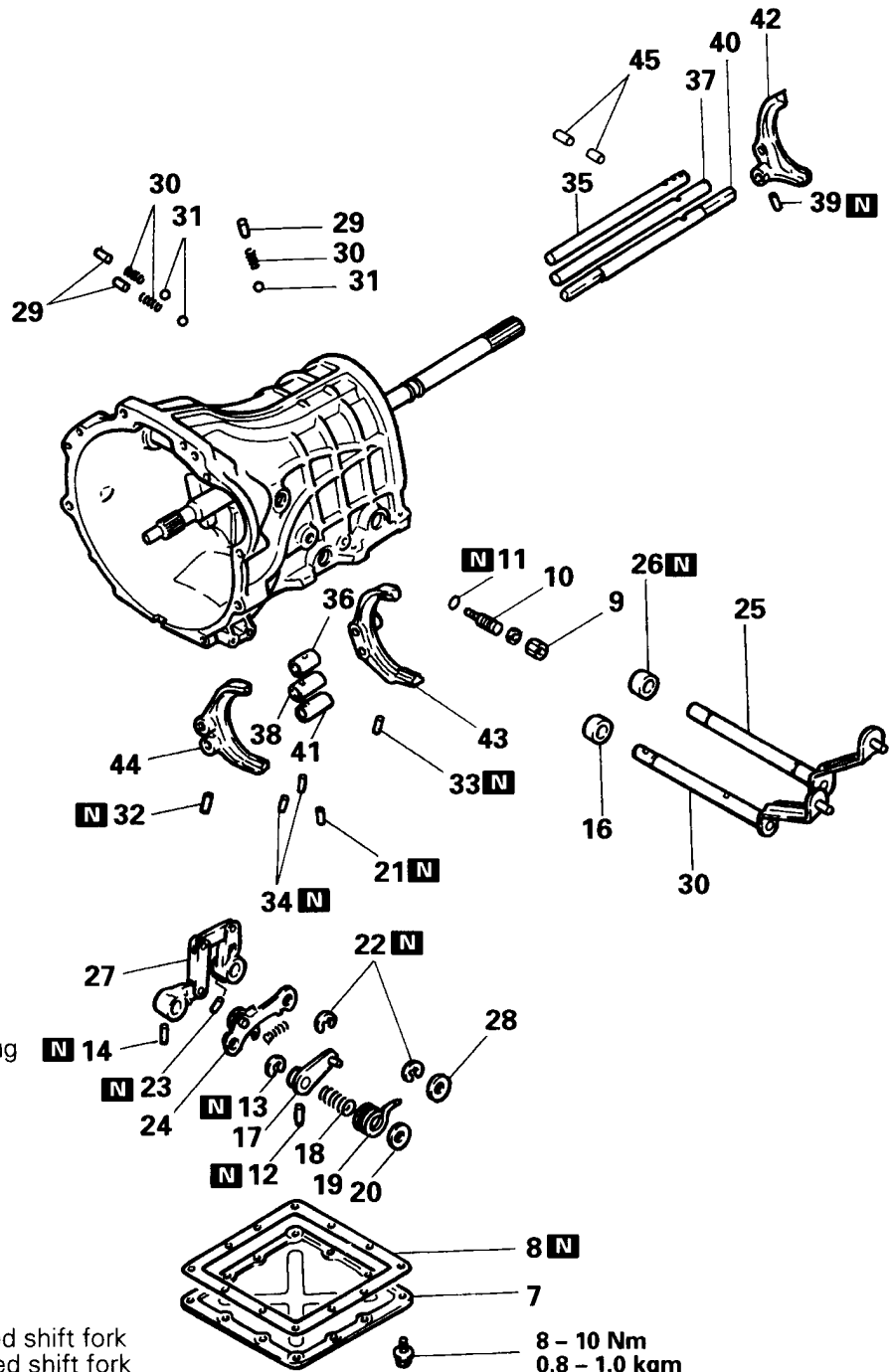

Disassembly steps

- 7. Under cover
- 8. Under cover gasket
- 9. Nut
- W** 10. Select adjuster
- M** **e** 11. O-ring
- n** 12. Spring pin
- d** 13. Snap ring
- N** 14. Spring pin
- 15. Select shaft
- 16. Oil seal
- 17. Adjust arm
- 18. Distance spring
- 19. Return spring
- 20. Spacer
- ©** **a** 21. Spring pin for OD-R shift lug
- m** 22. Snap ring
- P** **c** 23. Lock pin
- 24. Stopper bracket
- 25. Shift shaft
- 26. Oil seal
- 27. Control link
- 28. Spacer
- 29. Poppet plug
- b** 30. Poppet spring
- b** 31. Steel ball
- ©** **Y** 32. Spring pin for 3rd-4th speed shift fork
- ©** **Z** 33. Spring pin for 1st-2nd speed shift fork
- ©** **Z** 34. Spring pin for 3rd-4th speed shift lug and 1st-2nd speed shift lug
- 35. 1st-2nd speed shift rail
- 36. 1st-2nd speed shift lug
- 37. 3rd-4th speed shift rail
- 38. 3rd-4th speed shift lug
- ©** **X** 39. Spring pin for OD-R shift fork
- 40. OD-R shift rail
- 41. OD-R shift lug
- 42. OD-R shift fork
- 43. 1st-2nd speed shift fork
- 44. 3rd-4th speed shift fork
- 45. Interlock plunger

8 - 10 Nm
0.8 - 1.0 kgm
6 - 7 ft.lbs.

R5M21-7-E

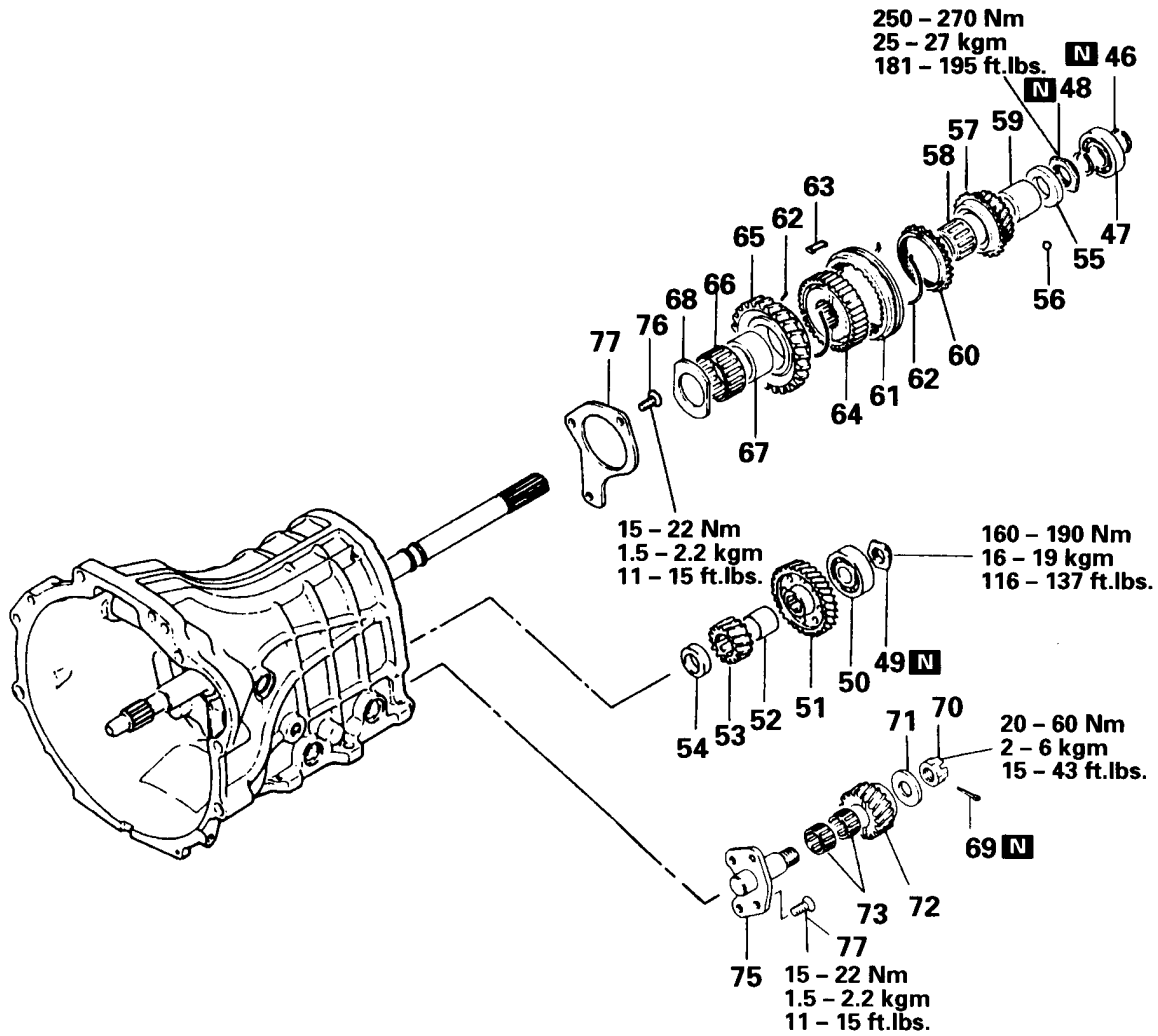

Disassembly steps

- | | |
|---|--|
| <ul style="list-style-type: none"> P 46. Snap ring P 47. Mainshaft rear bearing E S 48. Mainshaft lock nut V 49. Countershaft lock nut U 50. Countershaft rear bearing 51. Counter overdrive gear 52. Spacer 53. Counter reverse gear 54. Spacer 55. Spacer 56. Steel ball 57. Overdrive gear 58. Needle bearing F R 59. Bearing sleeve Q 60. Synchronizer ring O 61. Synchronizer sleeve | <ul style="list-style-type: none"> P 62. Synchronizer spring P 63. Synchronizer key O 64. OD-R synchronizer hub 65. Reverse gear 66. Needle bearing N 67. Bearing sleeve 68. Spacer 69. Split pin 70. Slotted nut 71. Thrust washer 72. Reverse idler gear 73. Needle bearing M 74. Bolt G L 75. Reverse idler gear shaft K 76. Bolt 77. Rear bearing retainer |
|---|--|

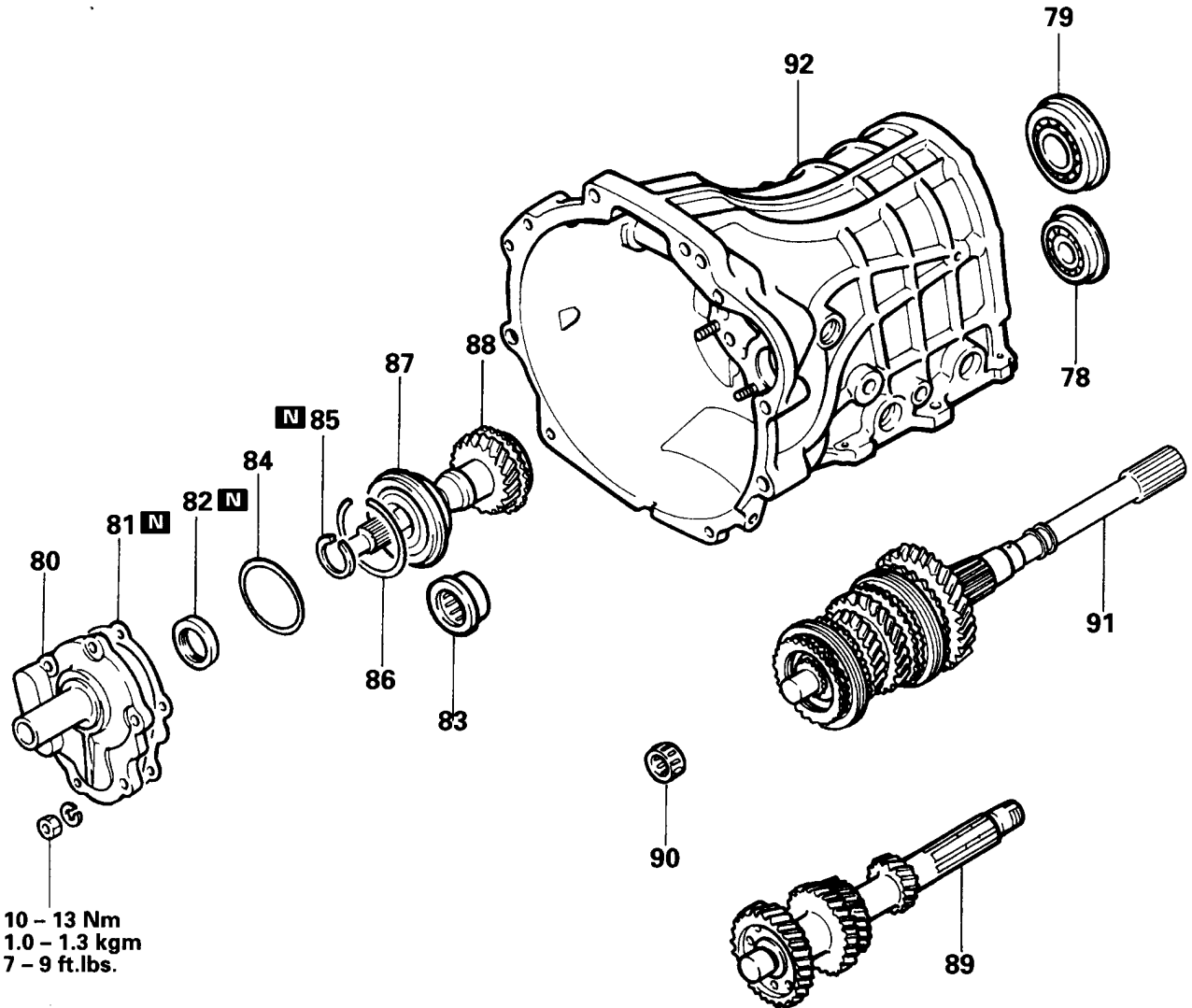

10 - 13 Nm
1.0 - 1.3 kgm
7 - 9 ft.lbs.

Disassembly steps

- (H) (I) 78. Countershaft center bearing
- (I) (H) 79. Mainshaft center bearing
- 80. Front bearing retainer
- (G) 81. Front bearing retainer gasket
- (E) 82. Oil seal
- (J) (D) 83. Countershaft front bearing
- (F) 84. Spacer
- (C) 85. Snap ring

- (K) (B) 86. Snap ring
- 87. Maindrive gear bearing
- 88. Maindrive gear
- 89. Countershaft
- 90. Mainshaft front bearing
- 91. Mainshaft
- 92. Transmission case

R5M21-7-Q

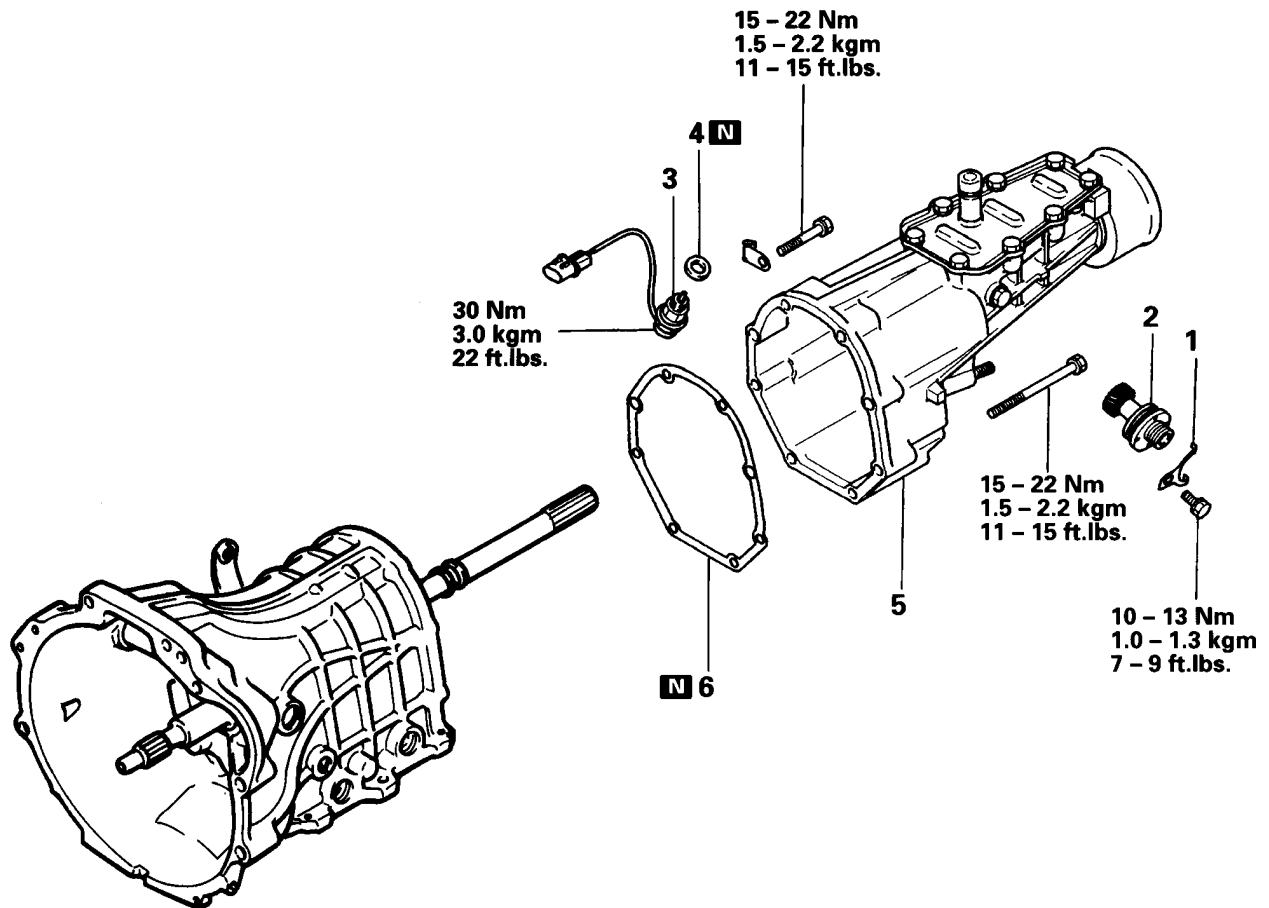
**Disassembly steps**

1. Stopper plate
- g 2. Speedometer gear
3. Backup lamp switch
4. Gasket
5. Extension housing
- h 6. Extension housing gasket

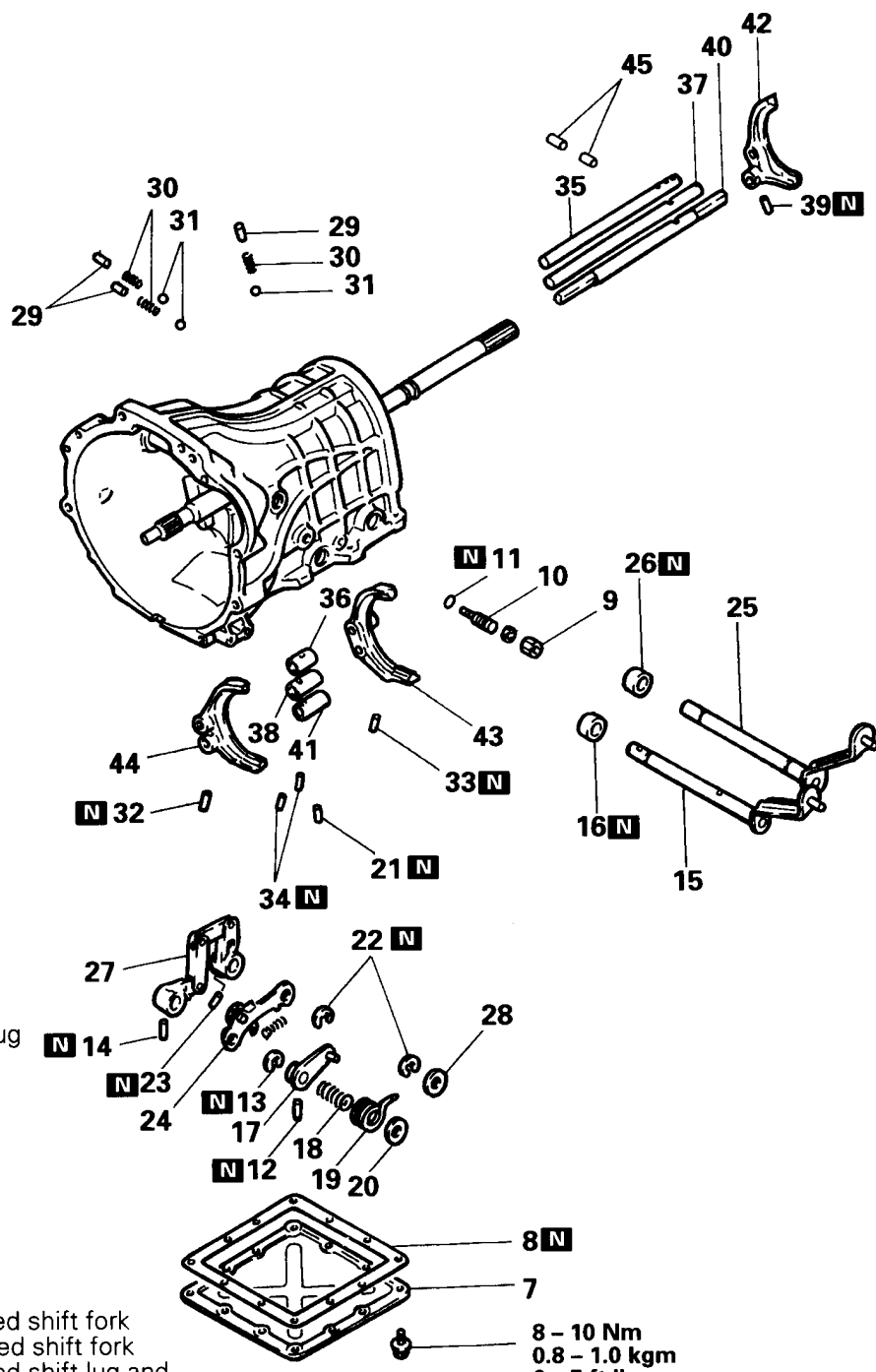

Disassembly steps

- 7. Under cover
- 8. Under cover gasket
- 9. Nut
- W** 10. Select adjuster
- M** **e** 11. O-ring
- n** 12. Spring pin
- d** 13. Snap ring
- N** 14. Spring pin
- 15. Select shaft
- 16. Oil seal
- 17. Adjust arm
- 18. Distance spring
- 19. Return spring
- 20. Spacer
- C** **a** 21. Spring pin for OD-R shift lug
- m** 22. Snap ring
- P** **c** 23. Lock pin
- 24. Stopper bracket
- 25. Shift shaft
- 26. Oil seal
- 27. Control link
- 28. Spacer
- 29. Poppet plug
- b** 30. Poppet spring
- b** 31. Steel ball
- C** **Y** 32. Spring pin for 3rd-4th speed shift fork
- C** **Y** 33. Spring pin for 1st-2nd speed shift fork
- C** **Z** 34. Spring pin for 3rd-4th speed shift lug and 1st-2nd speed shift lug
- 35. 1st-2nd speed shift rail
- 36. 1st-2nd speed shift lug
- 37. 3rd-4th speed shift rail
- 38. 3rd-4th speed shift lug
- D** **X** 39. Spring pin for OD-R shift fork
- 40. OD-R shift rail
- 41. OD-R shift lug
- 42. OD-R shift fork
- 43. 1st-2nd speed shift fork
- 44. 3rd-4th speed shift fork
- 45. Interlock plunger

8 - 10 Nm
0.8 - 1.0 kgm
6 - 7 ft.lbs.

R5M21-7-Q

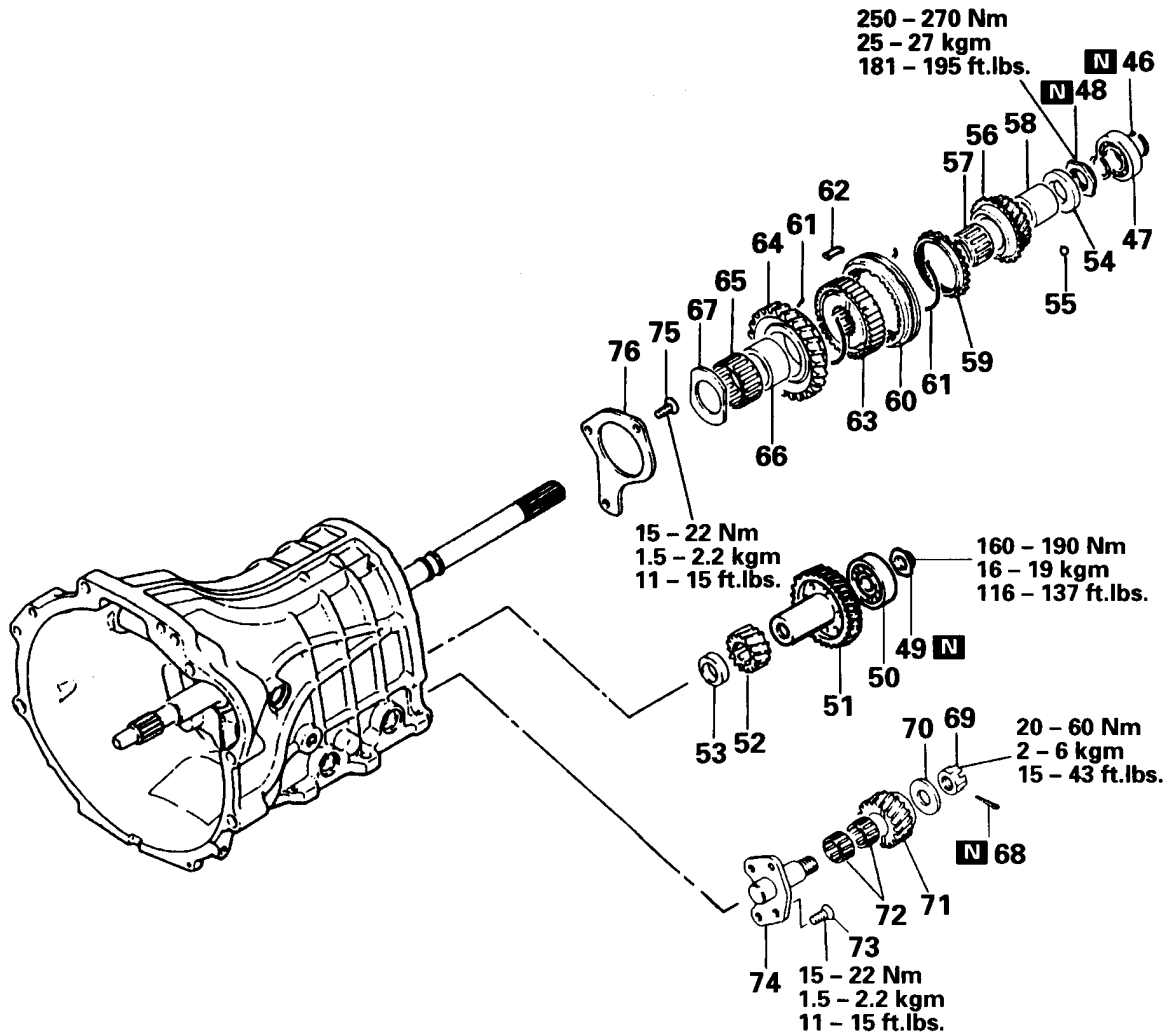

Disassembly steps

- | | |
|---|--|
| <ul style="list-style-type: none"> P 46. Snap ring P 47. Mainshaft rear bearing E S 48. Mainshaft lock nut V 49. Countershaft lock nut U 50. Countershaft rear bearing 51. Counter overdrive gear 52. Counter reverse gear 53. Spacer 54. Spacer 55. Steel ball 56. Overdrive gear 57. Needle bearing F R 58. Bearing sleeve Q 59. Synchronizer ring O 60. Synchronizer sleeve P 61. Synchronizer spring | <ul style="list-style-type: none"> P 62. Synchronizer key O 63. OD-R synchronizer hub 64. Reverse gear 65. Needle bearing N 66. Bearing sleeve 67. Spacer 68. Split pin 69. Slotted nut 70. Thrust washer 71. Reverse idler gear 72. Needle bearing M 73. Bolt G L 74. Reverse idler gear shaft K 75. Bolt 76. Rear bearing retainer |
|---|--|

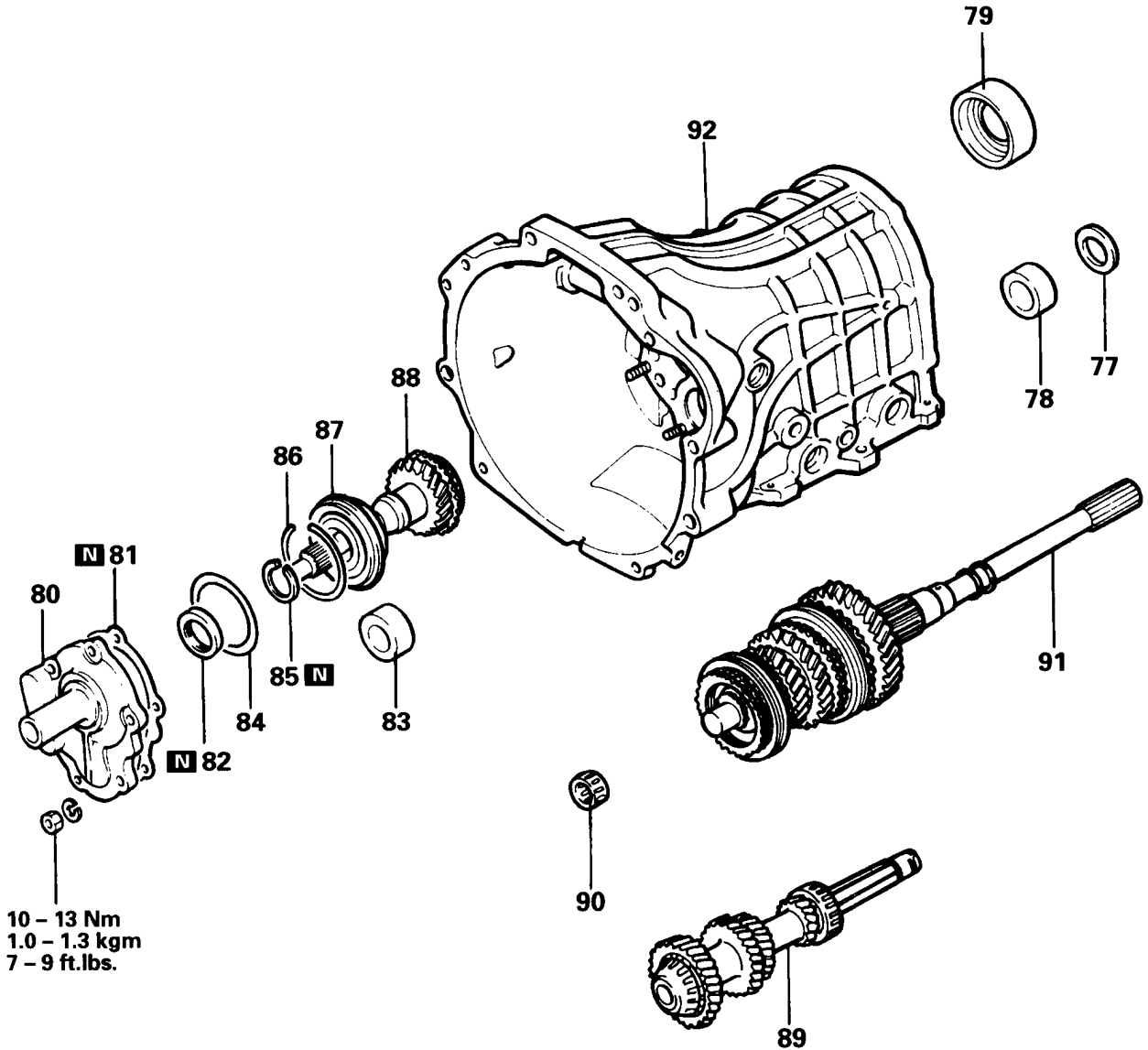

10 - 13 Nm
1.0 - 1.3 kgm
7 - 9 ft.lbs.

Disassembly steps

- Ⓝ 77. Spacer
- Ⓝ 78. Countershaft bearing outer race
- Ⓝ 79. Mainshaft center bearing
- Ⓝ 80. Front bearing retainer
- Ⓝ 81. Front bearing retainer gasket
- Ⓝ 82. Oil seal
- Ⓝ 83. Countershaft front bearing outer race
- Ⓝ 84. Spacer
- Ⓝ 85. Snap ring
- Ⓝ 86. Snap ring
- Ⓝ 87. Maindrive gear bearing
- Ⓝ 88. Maindrive gear
- Ⓝ 89. Countershaft assembly
- Ⓝ 90. Mainshaft front bearing
- Ⓝ 91. Mainshaft assembly
- Ⓝ 92. Transmission case

R5M21-7-G

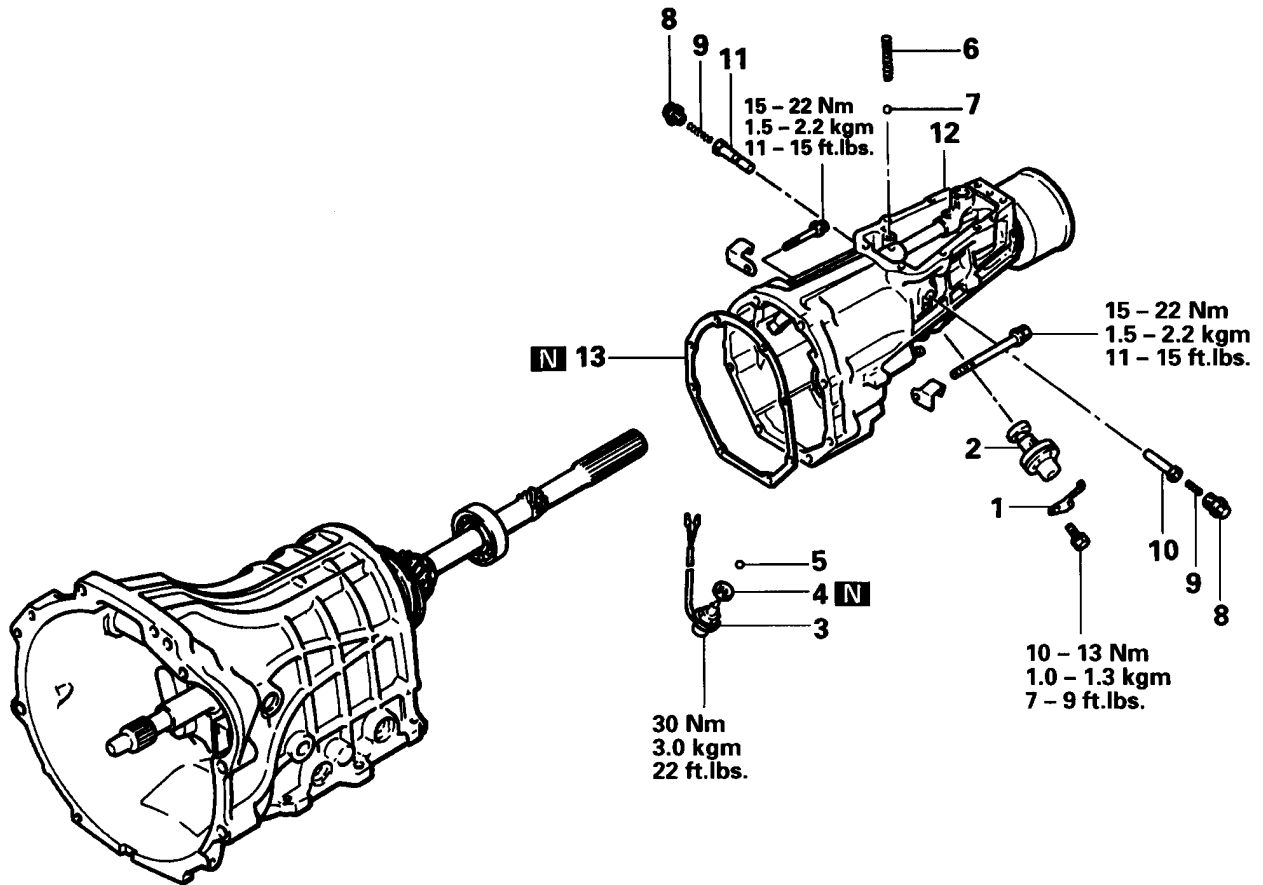
**Disassembly steps**

1. Sleeve clamp
- g** 2. Speedometer gear
3. Backup lamp switch
4. Gasket
5. Steel ball
6. Resistance spring
7. Steel ball
- r** 8. Seal plug
9. Spring
- q** 10. Neutral plunger A
- q** 11. Neutral plunger B
- i** 12. Extension housing
- h** 13. Extension housing gasket

TRM0060

R5M21-7-G

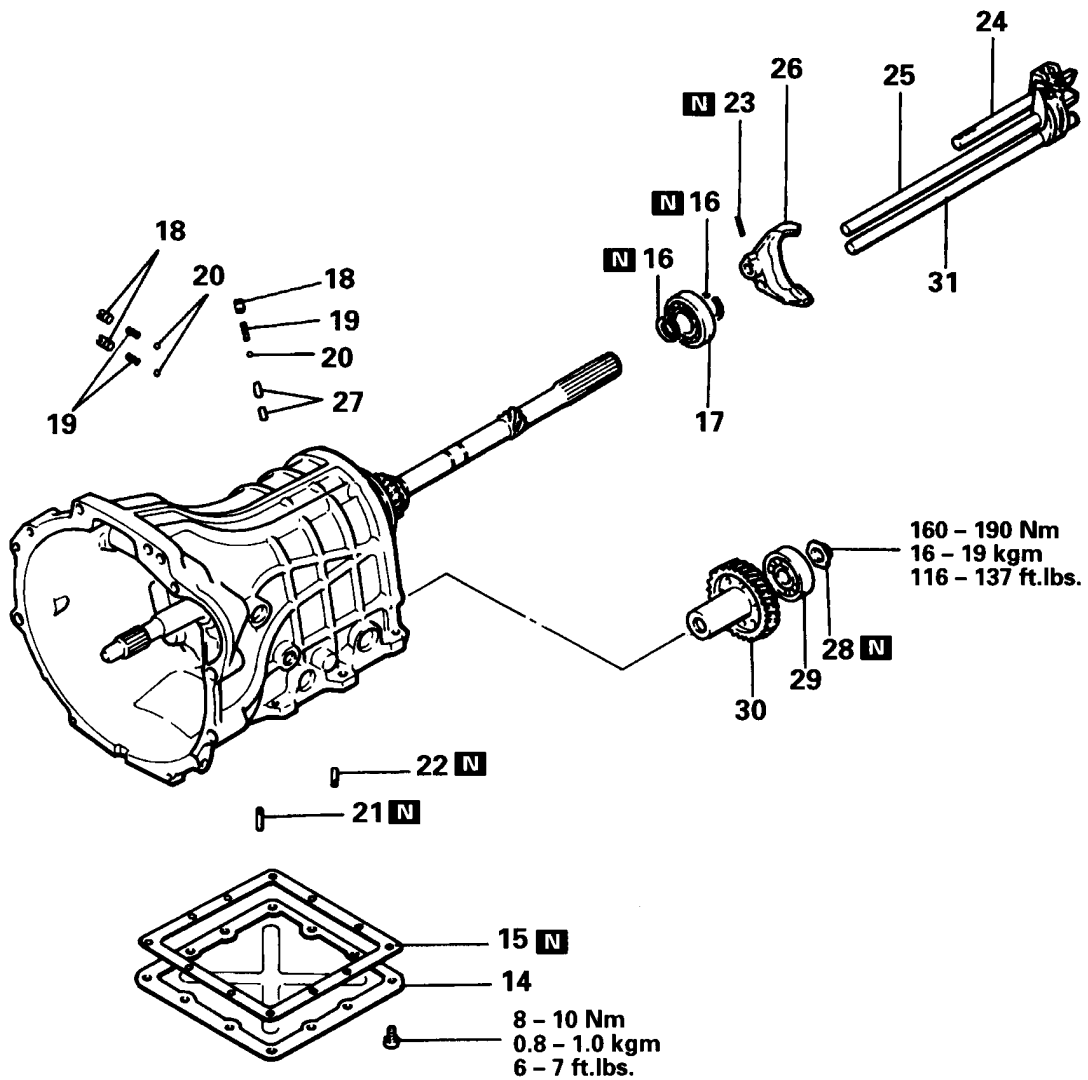

Disassembly steps

- 14. Under cover
- 15. Under cover gasket
- P** 16. Snap ring
- P** 17. Mainshaft rear bearing
- 18. Poppet plug
- b** 19. Poppet spring
- b** 20. Steel ball
- C** **Y** 21. Spring pin for 3rd-4th speed shift fork
- C** **Y** 22. Spring pin for 1st-2nd speed shift fork
- D** **X** 23. Spring pin for OD-R shift fork
- 24. OD-R shift rail
- 25. 3rd-4th speed shift rail
- 26. OD-R shift fork
- 27. Interlock plunger
- V** **U** 28. Countershaft lock nut
- V** **U** 29. Countershaft rear bearing
- 30. Counter overdrive gear
- 31. 1st-2nd speed shift rail

TRM0771

R5M21-7-G

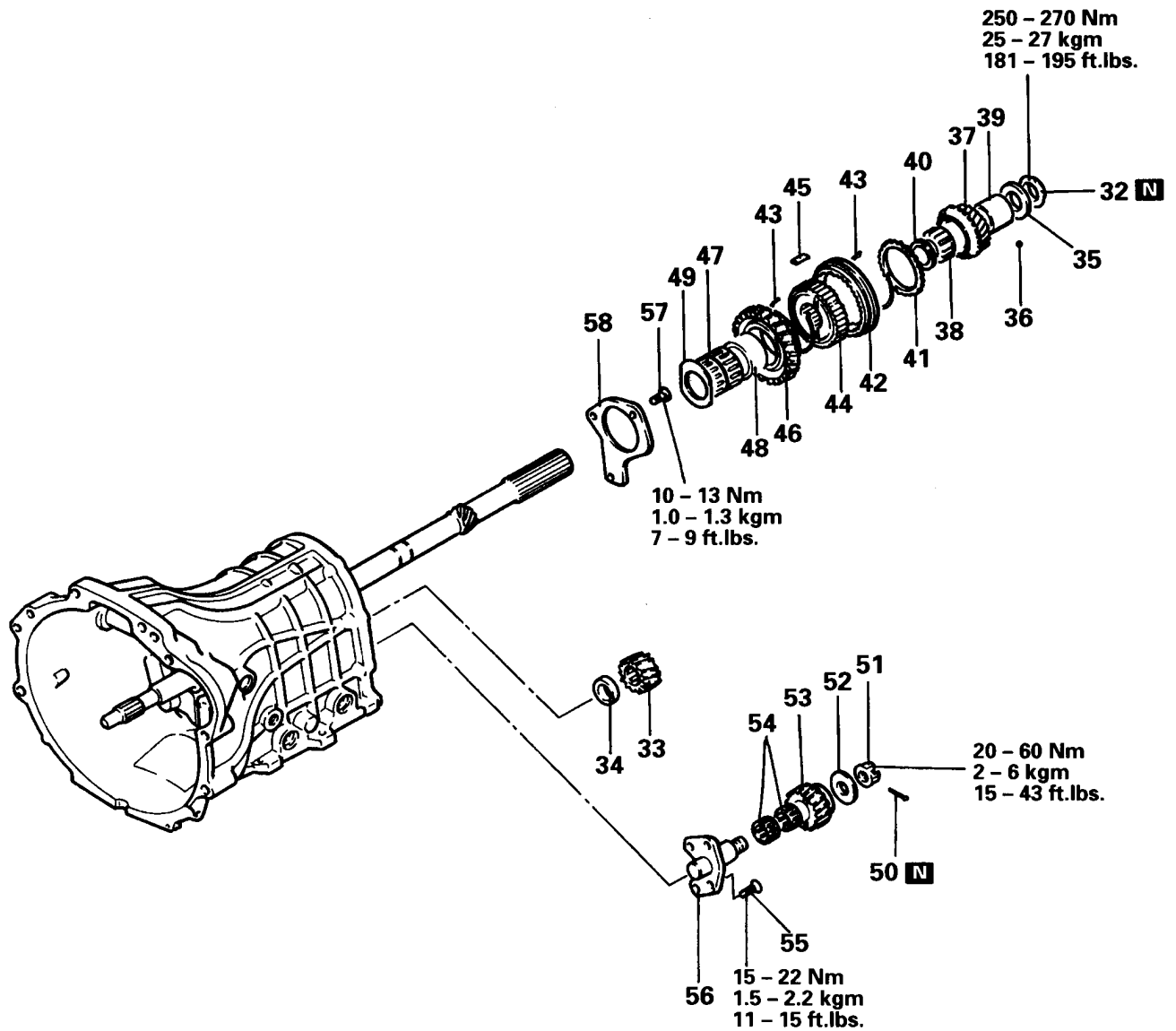

Disassembly steps

- Ⓔ Ⓢ 32. Mainshaft lock nut
- 33. Counter reverse gear
- 34. Spacer
- 35. Spacer
- 36. Steel ball
- 37. Overdrive gear
- 38. Needle bearing
- Ⓕ Ⓡ 39. Bearing sleeve
- 40. Bearing spacer
- Ⓚ 41. Overdrive synchronizer ring
- Ⓚ 42. OD-R synchronizer sleeve
- Ⓚ 43. OD-R synchronizer spring
- Ⓚ 44. OD-R synchronizer hub
- Ⓚ 45. OD-R synchronizer key
- 46. Reverse gear
- 47. Needle bearing
- Ⓝ 48. Bearing sleeve
- 49. Spacer
- 50. Split pin
- 51. Slotted nut
- 52. Thrust washer
- 53. Reverse idler gear
- 54. Needle bearing
- Ⓒ Ⓛ 55. Bolt
- Ⓒ Ⓛ 56. Reverse idler gear shaft
- Ⓒ Ⓚ 57. Bolt
- 58. Rear bearing retainer

R5M21-7-G

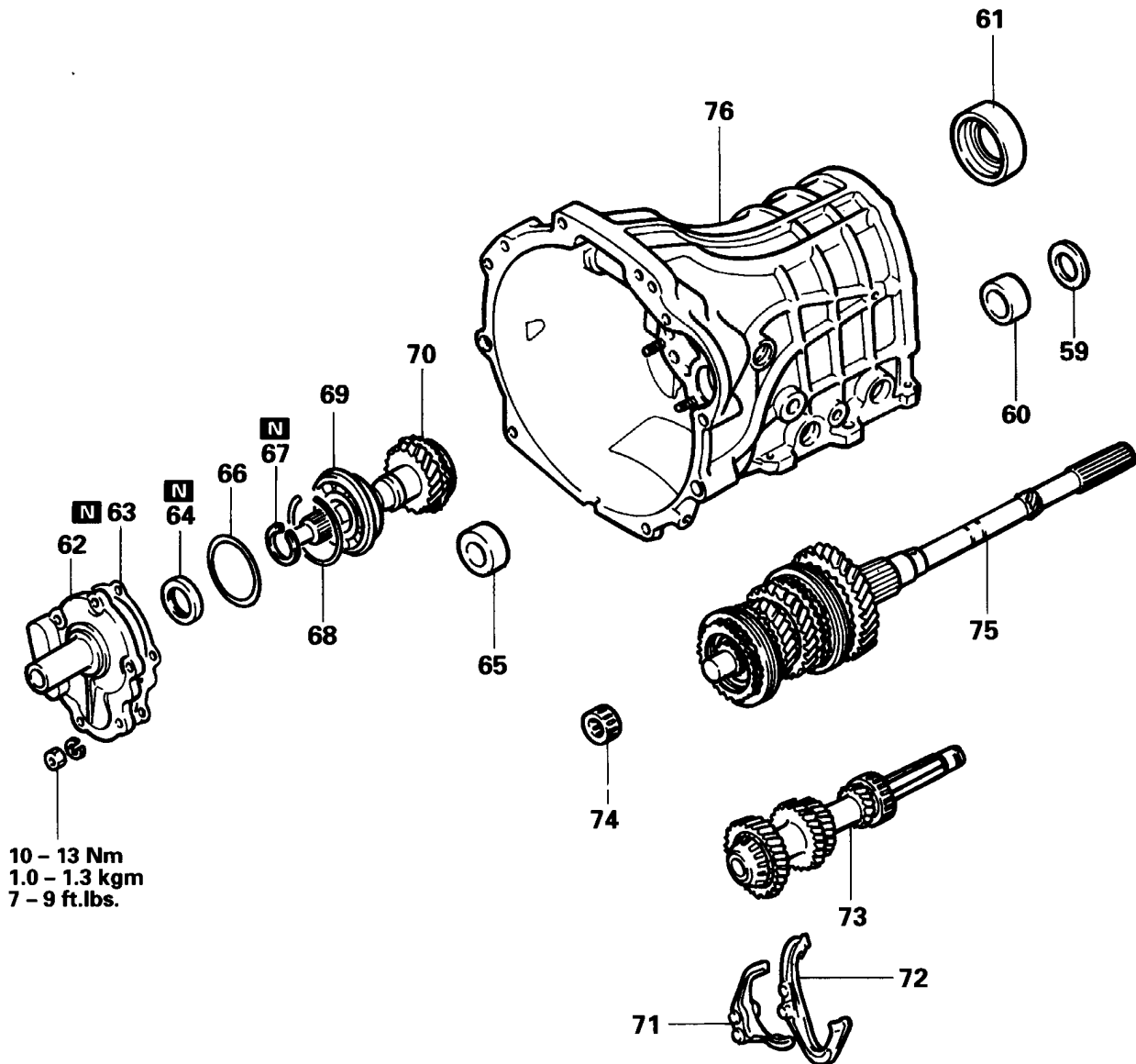

10 - 13 Nm
1.0 - 1.3 kgm
7 - 9 ft.lbs.

Disassembly steps

- J 59. Spacer
- 60. Countershaft center bearing outer race
- 61. Mainshaft center bearing
- 62. Front bearing retainer
- G 63. Front bearing retainer gasket
- E 64. Oil seal
- 65. Countershaft front bearing outer race
- F 66. Spacer
- C 67. Snap ring
- 68. Snap ring
- Ⓚ □ B 69. Maindrive gear bearing
- 70. Maindrive gear
- 71. 3rd-4th speed shift fork
- 72. 1st-2nd speed shift fork
- 73. Countershaft assembly
- 74. Mainshaft front bearing
- 75. Mainshaft assembly
- 76. Transmission case

TRM0071

V5M21-1-D (KM145-6), V5M21-9-D

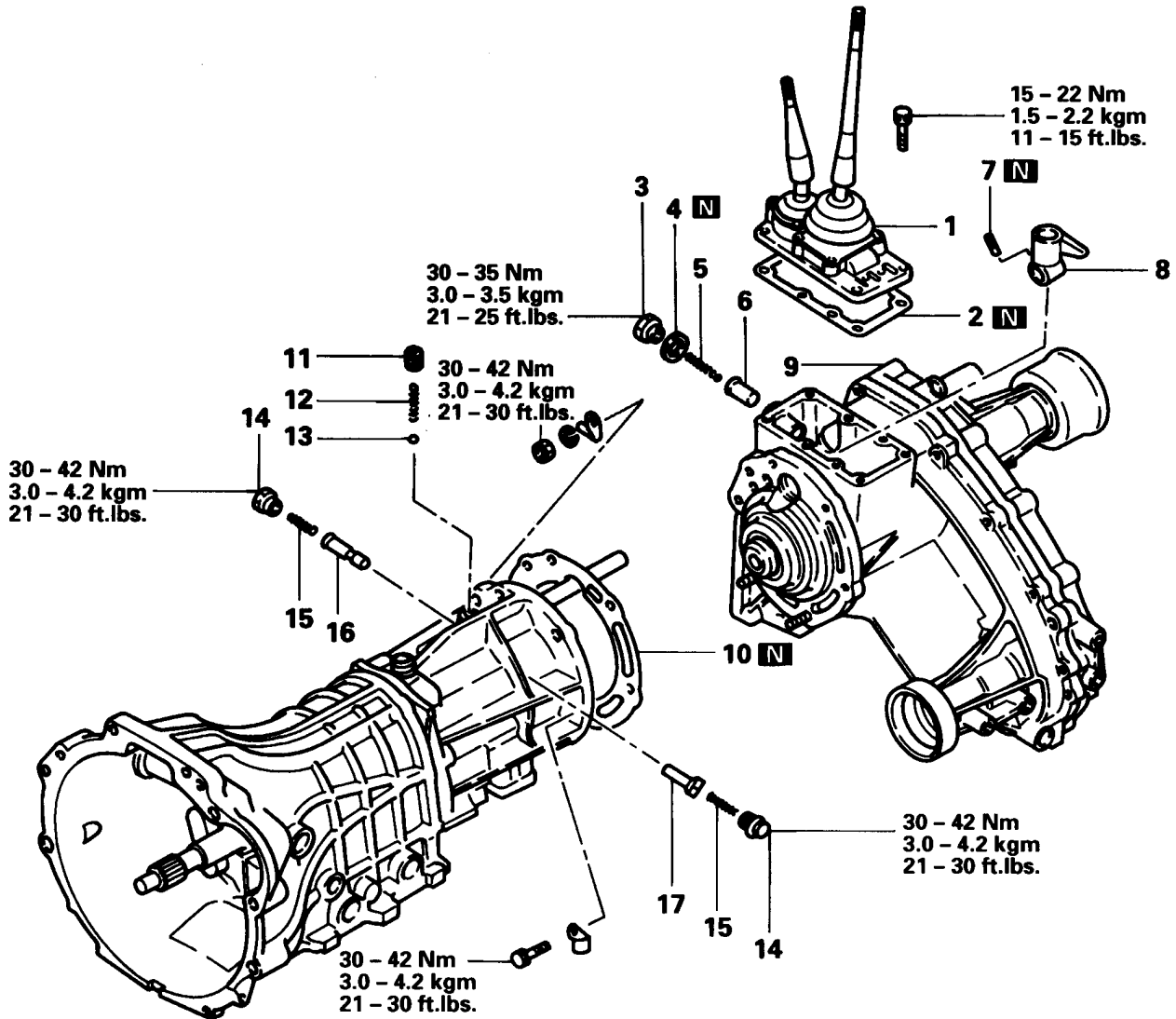
**Disassembly steps**

1. Control lever assembly
2. Gasket
3. Select plunger plug
4. Gasket
5. Select spring
6. Select plunger
- A** **I** 7. Spring pin
8. Change shifter
9. Transfer case assembly
- k** **s** 10. Adapter gasket
11. Plug
12. Spring
13. Steel ball
- r** 14. Seal plug
15. Neutral return spring
- q** 16. Neutral return plunger (B)
- q** 17. Neutral return plunger (A)

TRM0077

V5M21-1-D (KM145-6), V5M21-9-D

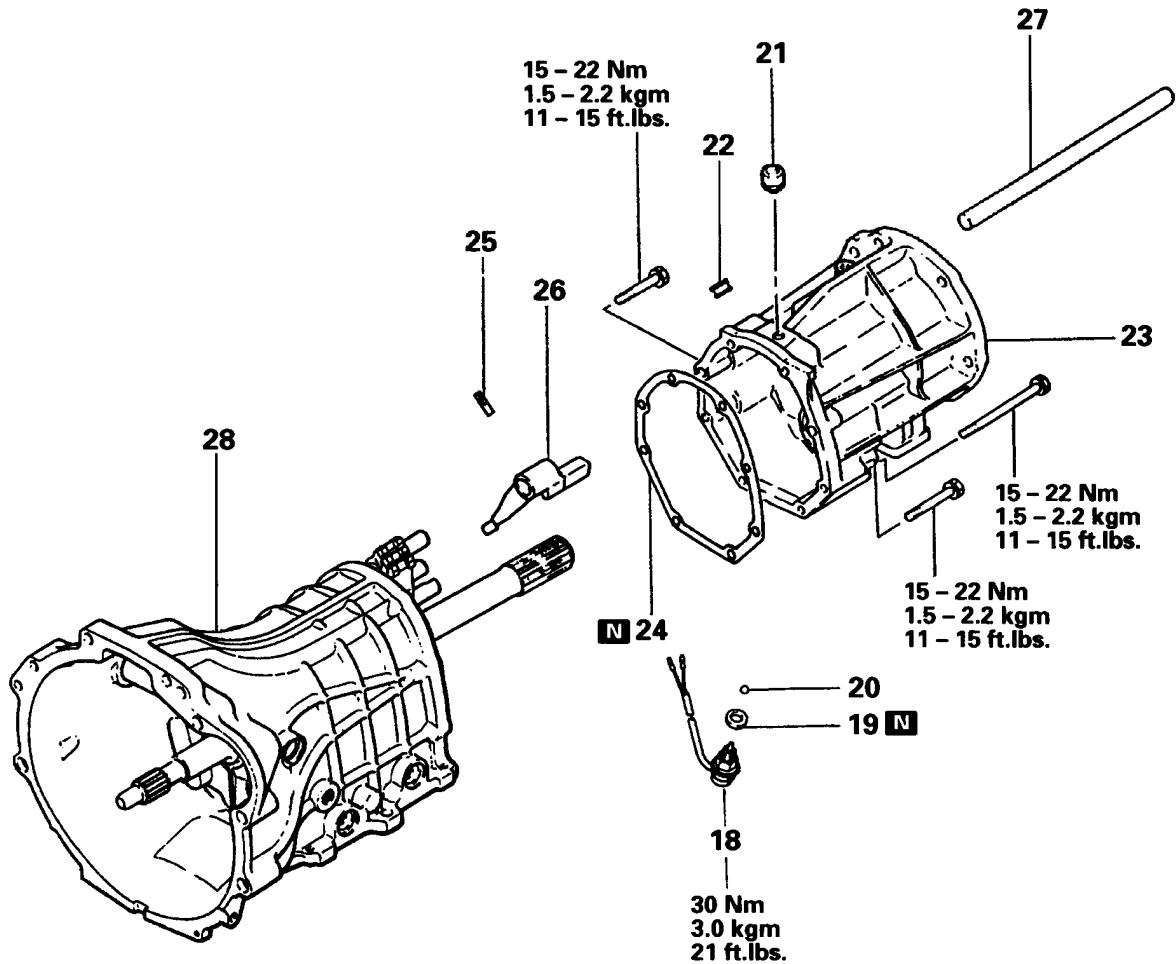

Disassembly steps

- 18. Backup lamp switch
- 19. Gasket
- 20. Steel ball
- [I] 21. Breather
- 22. Plug
- ⓑ [i] 23. Transfer adapter ←
- [h] 24. Case gasket ←
- [o] 25. Lock pin ←
- 26. Control finger ←
- 27. Control shaft ←
- 28. Transmission assembly

Caution
 The control finger and control shaft should be left installed in the transfer adapter as the lock pin cannot be removed. If any of these four parts requires replacement, order them all and replace them as a unit.

V5M21-1-D (KM145-6), V5M21-9-D

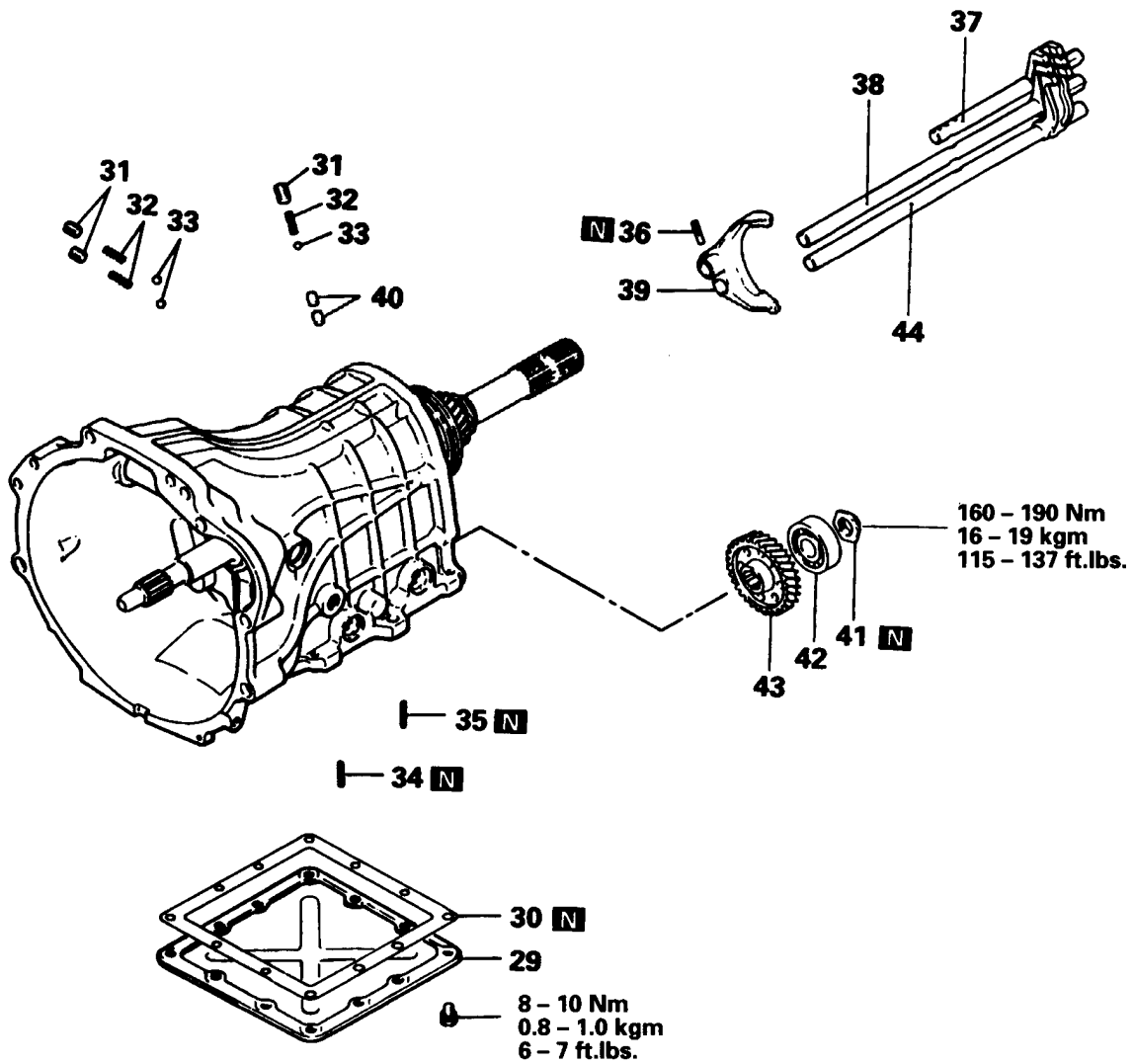

Disassembly steps

- 29. Under cover
- 30. Under cover gasket
- 31. Poppet plug
- b** 32. Poppet spring
- b** 33. Steel ball
- ©** **Y** 34. Spring pin for 3rd-4th speed shift fork
- ©** **Y** 35. Spring pin for 1st-2nd speed shift fork
- ©** **X** 36. Spring pin for OD-R shift fork
- 37. OD-R shift rail
- 38. 3rd-4th speed shift rail
- 39. OD-R shift fork
- 40. Interlock plunger
- V** 41. Countershaft lock nut
- U** 42. Countershaft rear bearing
- 43. Counter overdrive gear
- 44. 1st-2nd speed shift rail

V5M21-1-D (KM145-6), V5M21-9-D

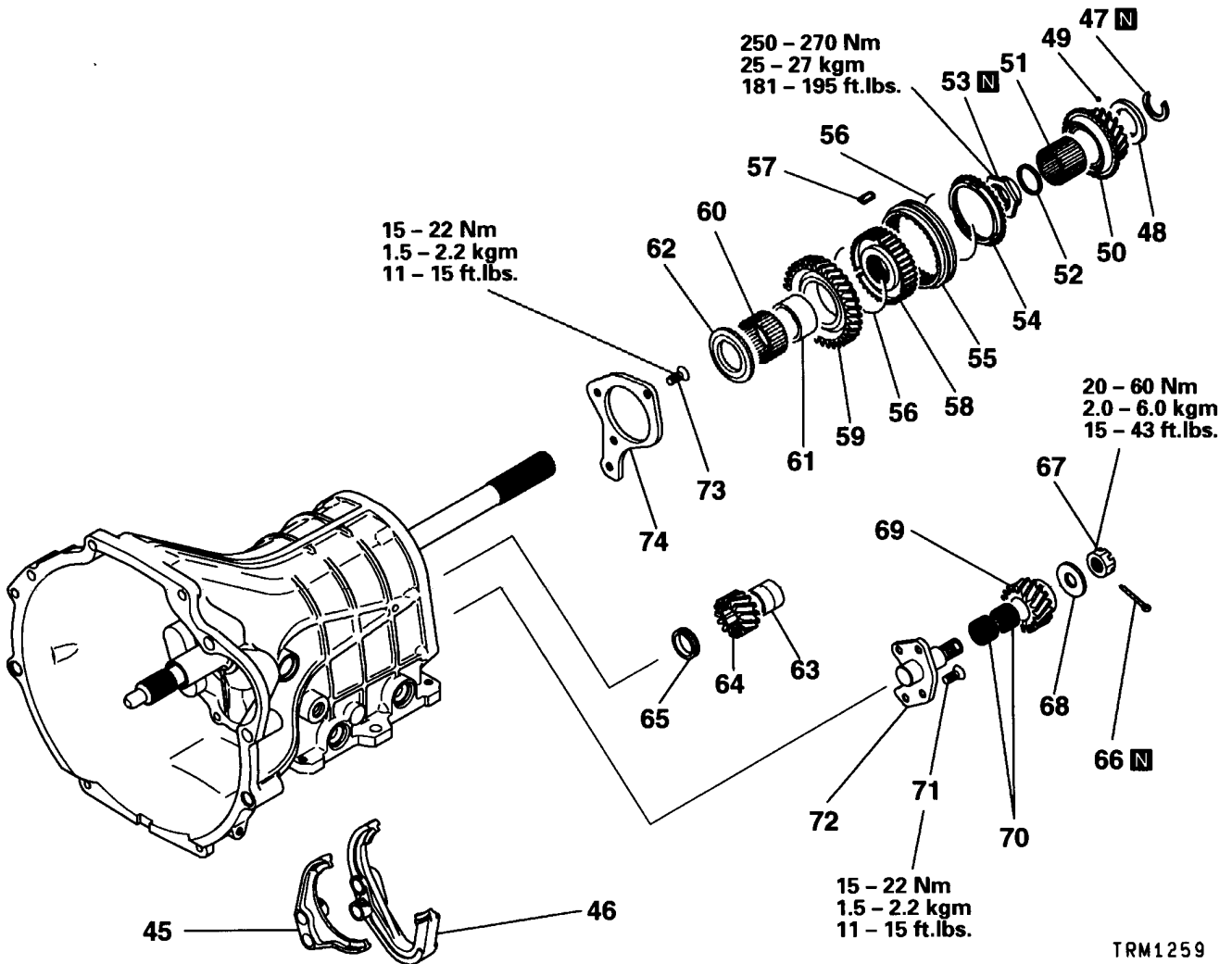

Disassembly steps

- 45. 3rd-4th speed shift fork
- 46. 1st-2nd speed shift fork
- 47. Snap ring
- 48. Spacer
- 49. Steel ball
- 50. Overdrive gear
- 51. Needle bearing
- 52. Bearing spacer
- ⑤

S
Q
O
P
P
O

 53. Lock nut
- ⑤

S
Q
O
P
P
O

 54. Overdrive synchronizer ring
- ⑤

S
Q
O
P
P
O

 55. OD-R synchronizer sleeve
- ⑤

S
Q
O
P
P
O

 56. OD-R synchronizer spring
- ⑤

S
Q
O
P
P
O

 57. OD-R synchronizer key
- ⑤

S
Q
O
P
P
O

 58. OD-R synchronizer hub
- 59. Reverse gear
- ⑥

M
L
K

 60. Needle bearing
- ⑥

M
L
K

 61. Reverse gear bearing sleeve
- 62. Spacer
- 63. Spacer
- 64. Counter reverse gear
- 65. Spacer
- 66. Split pin
- 67. Slotted nut
- 68. Thrust washer
- 69. Reverse idler gear
- 70. Needle bearing
- ⑥

M
L
K

 71. Bolt
- ⑥

M
L
K

 72. Reverse idler gear shaft
- 73. Bolt
- 74. Rear bearing retainer

V5M21-1-D (KM145-6), V5M21-9-D

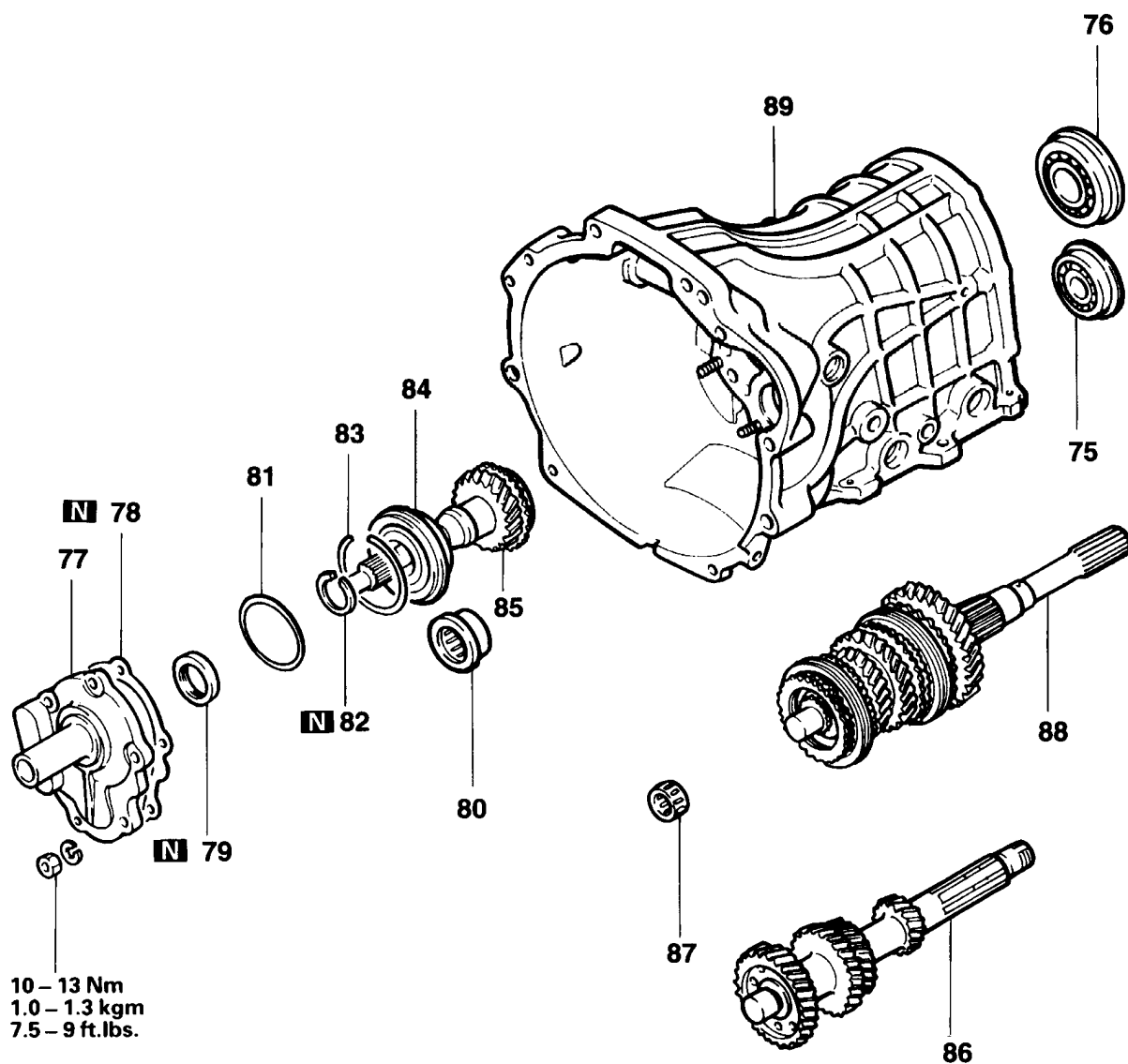
**Disassembly steps**

- (H) I 75. Countershaft center bearing
- (I) H 76. Mainshaft bearing
- 77. Front bearing retainer
- G 78. Front bearing retainer gasket
- E 79. Oil seal
- (J) D 80. Countershaft front bearing
- F 81. Spacer
- C 82. Snap ring
- (K) B 84. Maindrive gear bearing
- 85. Maindrive gear
- 86. Countershaft
- 87. Mainshaft front bearing
- 88. Mainshaft assembly
- 89. Transmission case

V5M21-1-P (KM145-7, A), V5M21-4-P, V5M21-6-P, I, V5M21-9-P

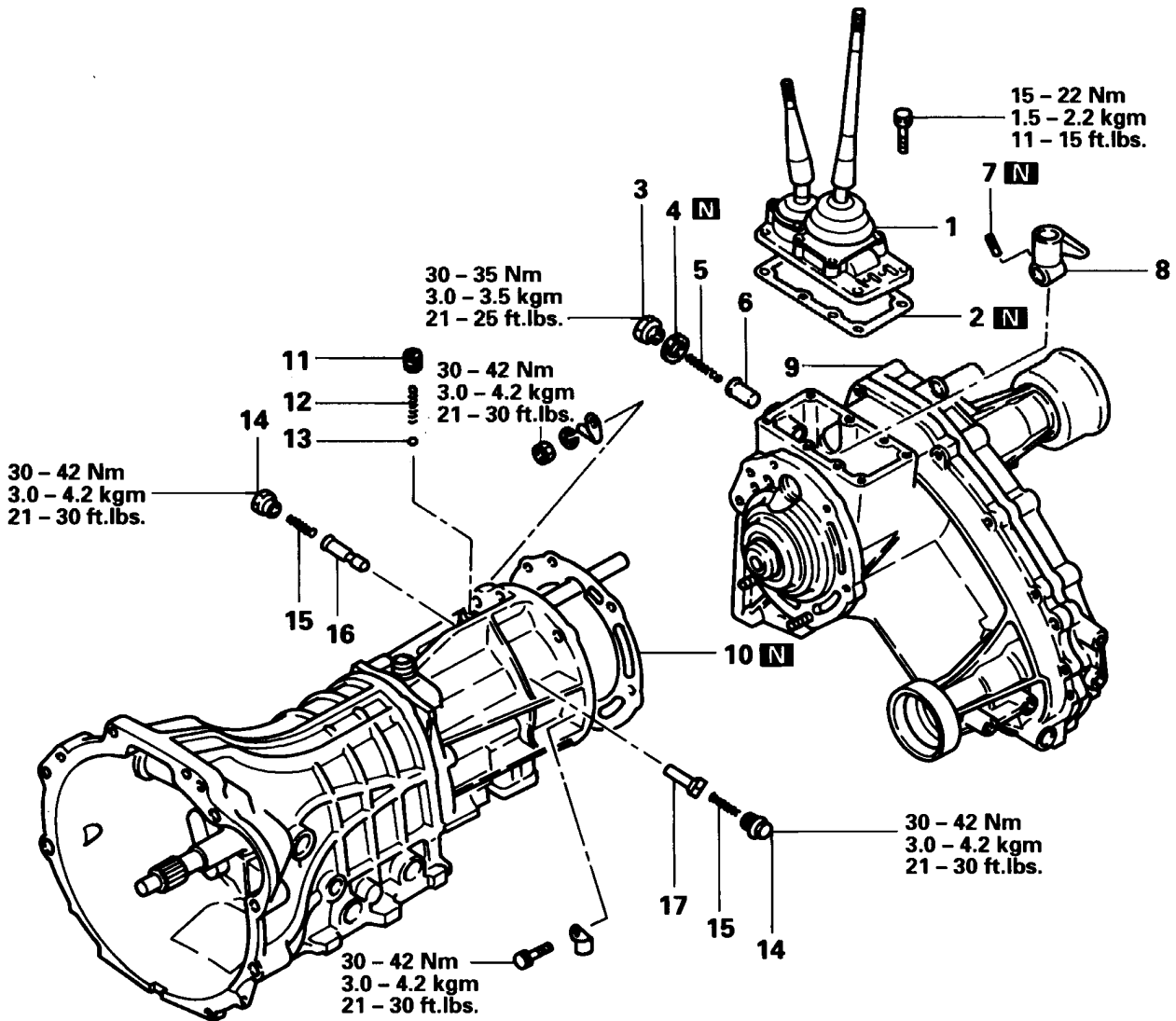

Disassembly steps

1. Control lever assembly
2. Gasket
3. Select plunger plug
4. Gasket
5. Select spring
6. Select plunger
- ① I 7. Spring pin
8. Change shifter
9. Transfer case assembly
- Ⓚ 10. Adapter gasket
- Ⓢ 11. Plug
12. Spring
13. Steel ball
- Ⓡ 14. Seal plug
15. Neutral return spring
- Ⓚ 16. Neutral return plunger (B)
- Ⓚ 17. Neutral return plunger (A)

V5M21-1-P (KM145-7, A), V5M21-4-P, V5M21-6-P, I, V5M21-9-P

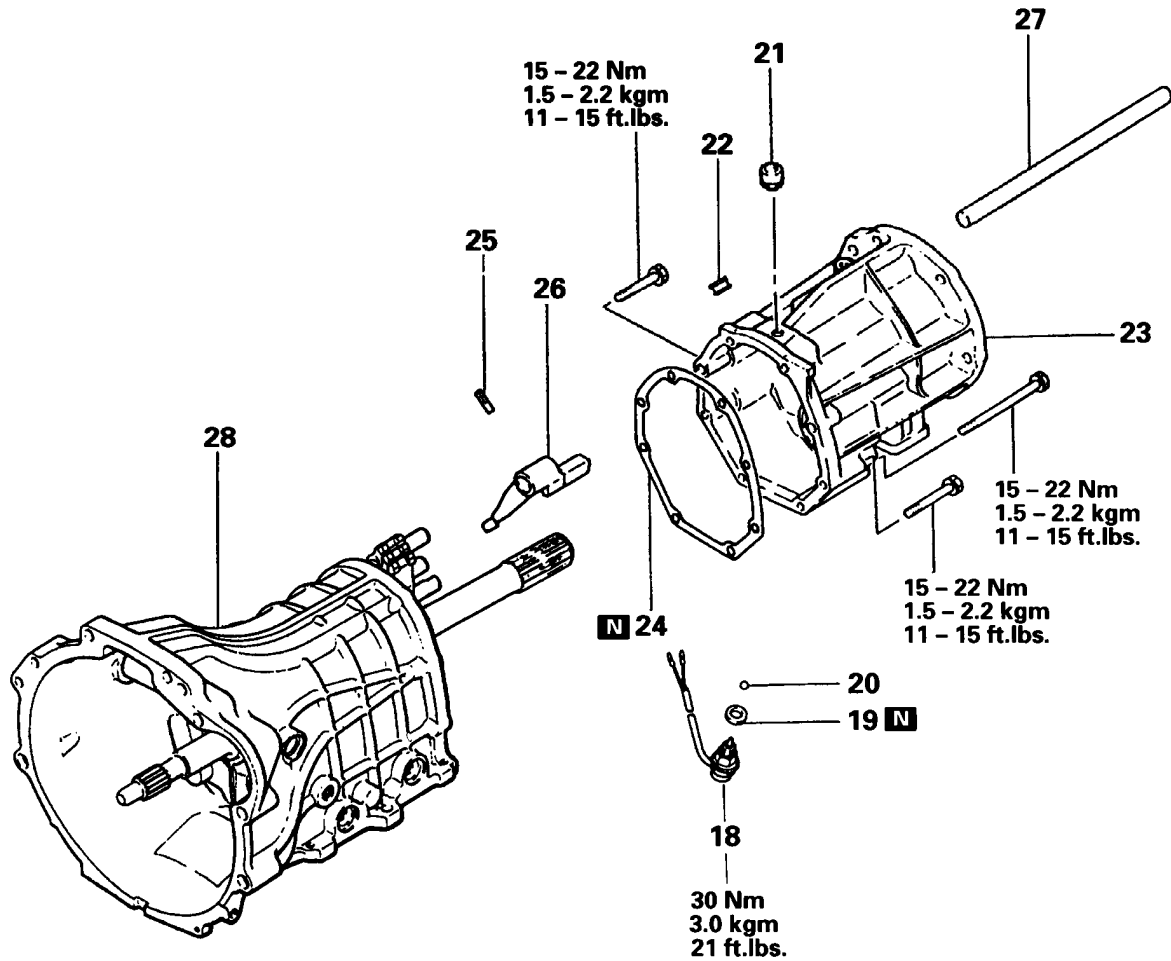

Disassembly steps

- 18. Backup lamp switch
- 19. Gasket
- 20. Steel ball
- 21. Breather
- 22. Plug
- 23. Transfer adapter
- 24. Case gasket
- 25. Lock pin
- 26. Control finger
- 27. Control shaft
- 28. Transmission assembly

Caution
 The control finger and control shaft should be left installed in the transfer adapter as the lock pin cannot be removed. If any of these four parts requires replacement, order them all and replace them as a unit.

V5M21-1-P (KM145-7, A), V5M21-4-P, V5M21-6-P, I, V5M21-9-P

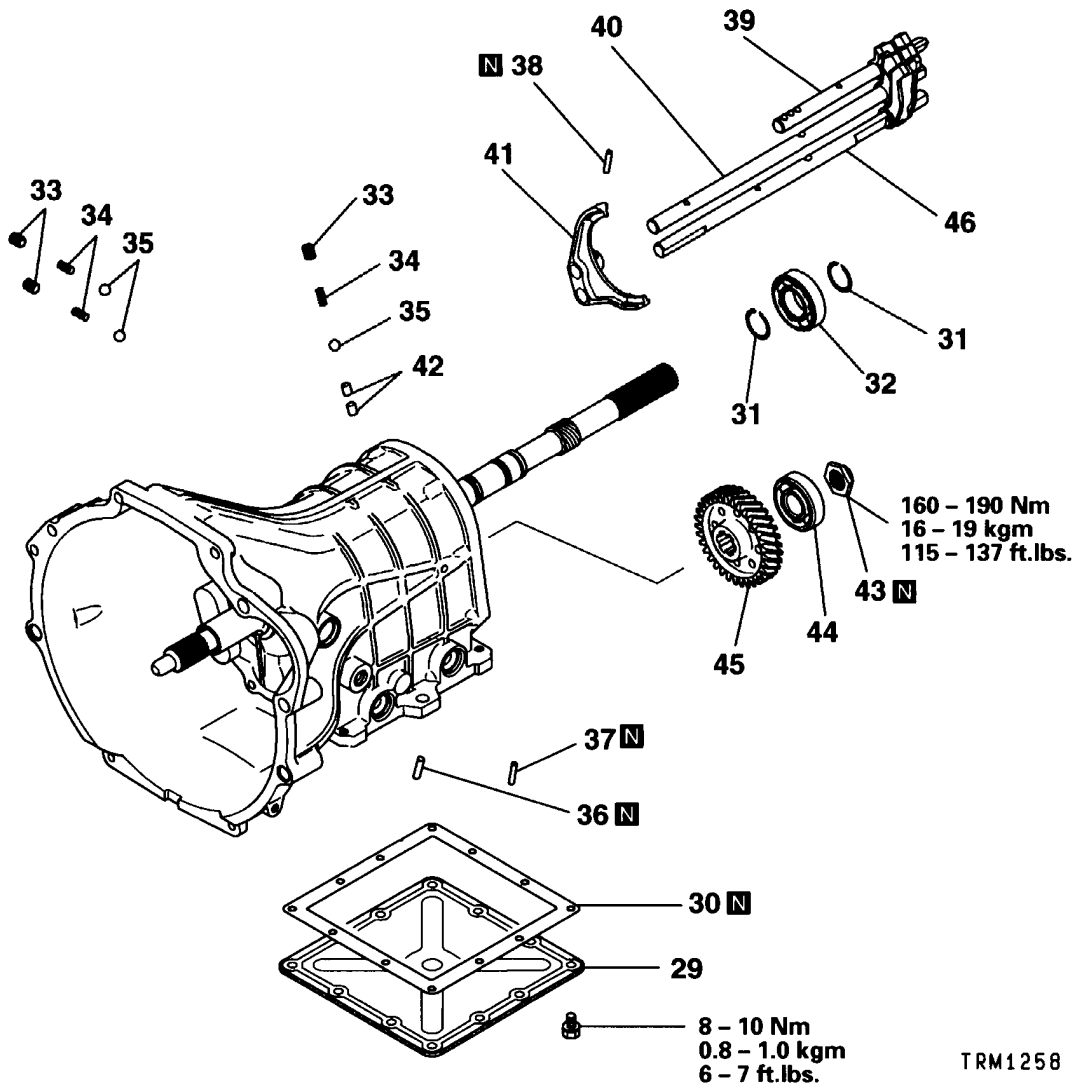

TRM1258

Disassembly steps

- 29. Under cover
- 30. Under cover gasket
- P** 31. Snap ring (V5M21-6-I only)
- P** 32. Mainshaft rear bearing (V5M21-6-I only)
- 33. Poppet plug
- b** 34. Poppet spring
- b** 35. Steel ball
- C** **Y** 36. Spring pin for 3rd-4th speed shift fork
- C** **Y** 37. Spring pin for 1st-2nd speed shift fork
- D** **X** 38. Spring pin for OD-R shift fork
- 39. OD-R shift rail
- 40. 3rd-4th speed shift rail
- 41. OD-R shift fork
- 42. Interlock plunger
- V** 43. Countershaft lock nut
- U** 44. Countershaft rear bearing
- 45. Counter overdrive gear
- 46. 1st-2nd speed shift rail

V5M21-1-P (KM145-7, A), V5M21-4-P, V5M21-6-P, I, V5M21-9-P

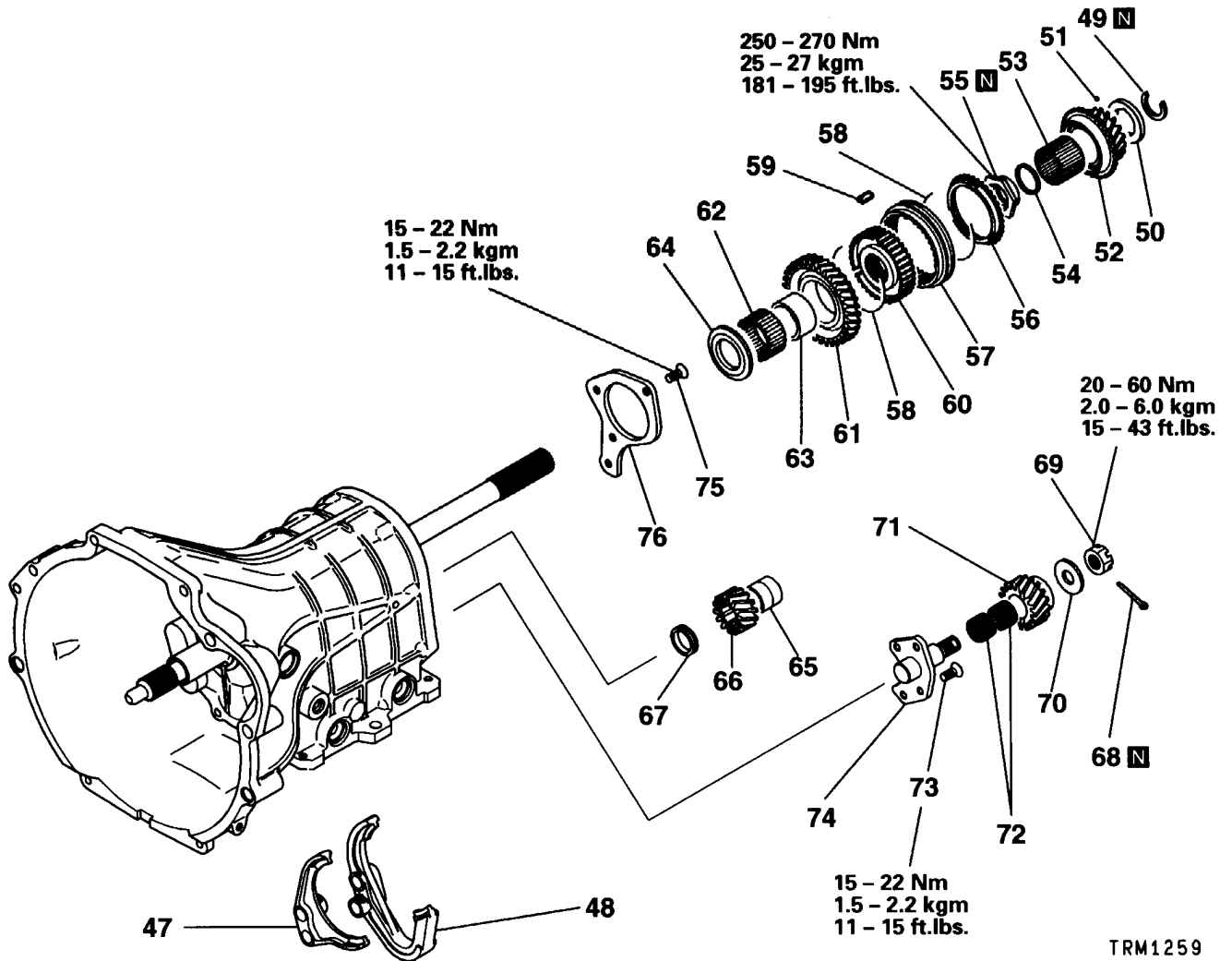

Disassembly steps

- 47. 3rd-4th speed shift fork
- 48. 1st-2nd speed shift fork
- 49. Snap ring
- 50. Spacer
- 51. Steel ball
- 52. Overdrive gear
- 53. Needle bearing
- 54. Bearing spacer
- ⑤

S
Q
O
P
O

 55. Lock nut
- | |
|---|
| S |
| Q |
| O |
| P |
| O |

 56. Overdrive synchronizer ring
- | |
|---|
| S |
| Q |
| O |
| P |
| O |

 57. OD-R synchronizer sleeve
- | |
|---|
| S |
| Q |
| O |
| P |
| O |

 58. OD-R synchronizer spring
- | |
|---|
| S |
| Q |
| O |
| P |
| O |

 59. OD-R synchronizer key
- | |
|---|
| S |
| Q |
| O |
| P |
| O |

 60. OD-R synchronizer hub
- 61. Reverse gear
- 62. Needle bearing
- Ⓝ 63. Reverse gear bearing sleeve
- 64. Spacer
- 65. Spacer
- 66. Counter reverse gear
- 67. Spacer
- 68. Split pin
- 69. Slotted nut
- 70. Thrust washer
- 71. Reverse idler gear
- 72. Needle bearing
- Ⓞ

M
L
K

 73. Bolt
- Ⓞ

M
L
K

 74. Reverse idler gear shaft
- 75. Bolt
- 76. Rear bearing retainer

V5M21-1-P (KM145-7, A), V5M21-4-P, V5M21-6-P, I, V5M21-9-P

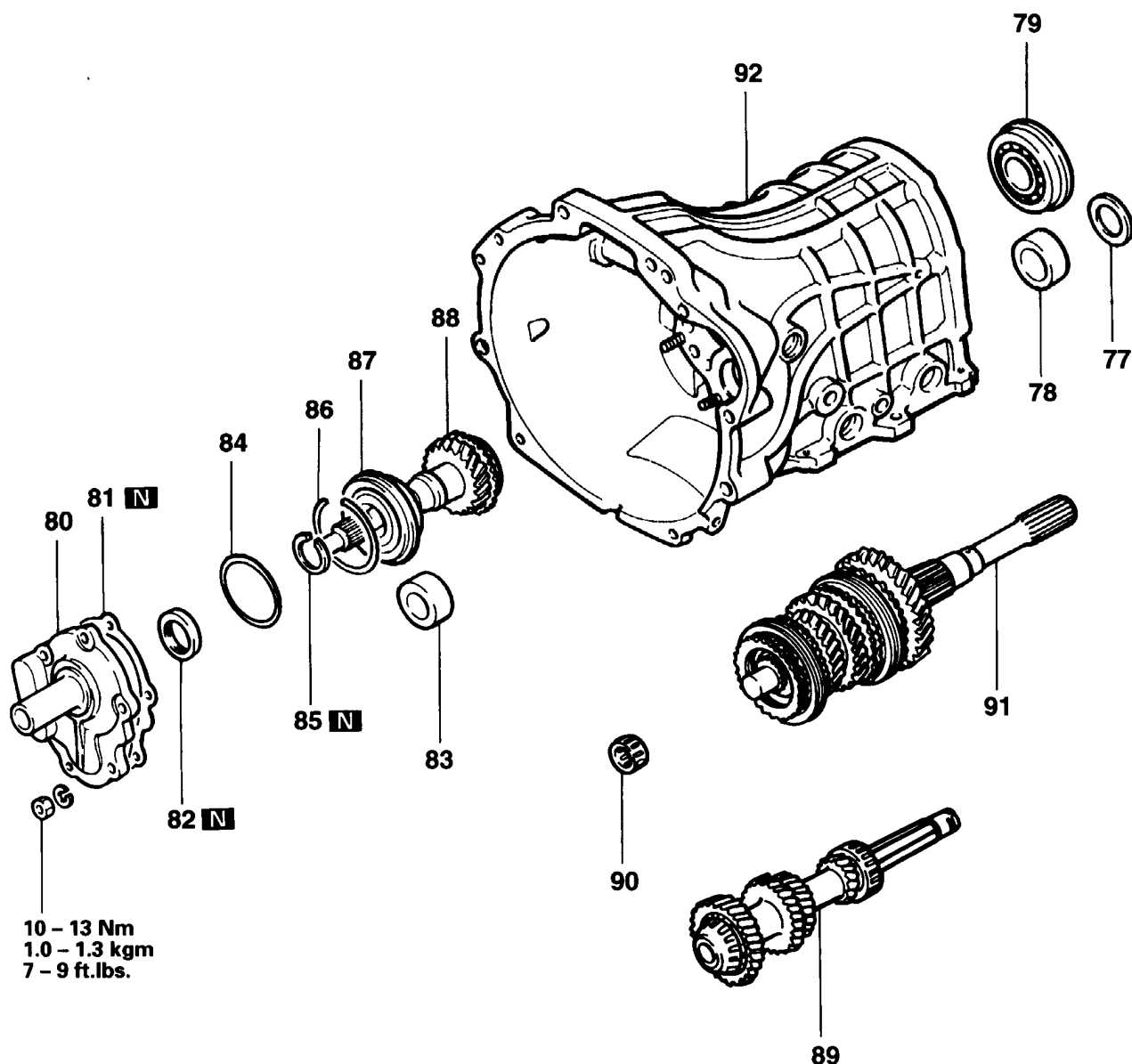

Disassembly steps

- J 77. Spacer
- 78. Countershaft center bearing outer race
- ① H 79. Mainshaft bearing
- 80. Front bearing retainer
- G 81. Front bearing retainer gasket
- E 82. Oil seal
- 83. Countershaft front bearing outer race
- F 84. Spacer
- C 85. Snap ring
- 86. Snap ring
- Ⓚ B 87. Maindrive gear bearing
- 88. Maindrive gear
- 89. Mainshaft front bearing
- 90. Countershaft assembly
- 91. Mainshaft assembly
- 92. Transmission case

TRM0081

V5M21-1-G, J, Q, V5M21-4-Q (KM145-8, 9, B, D)

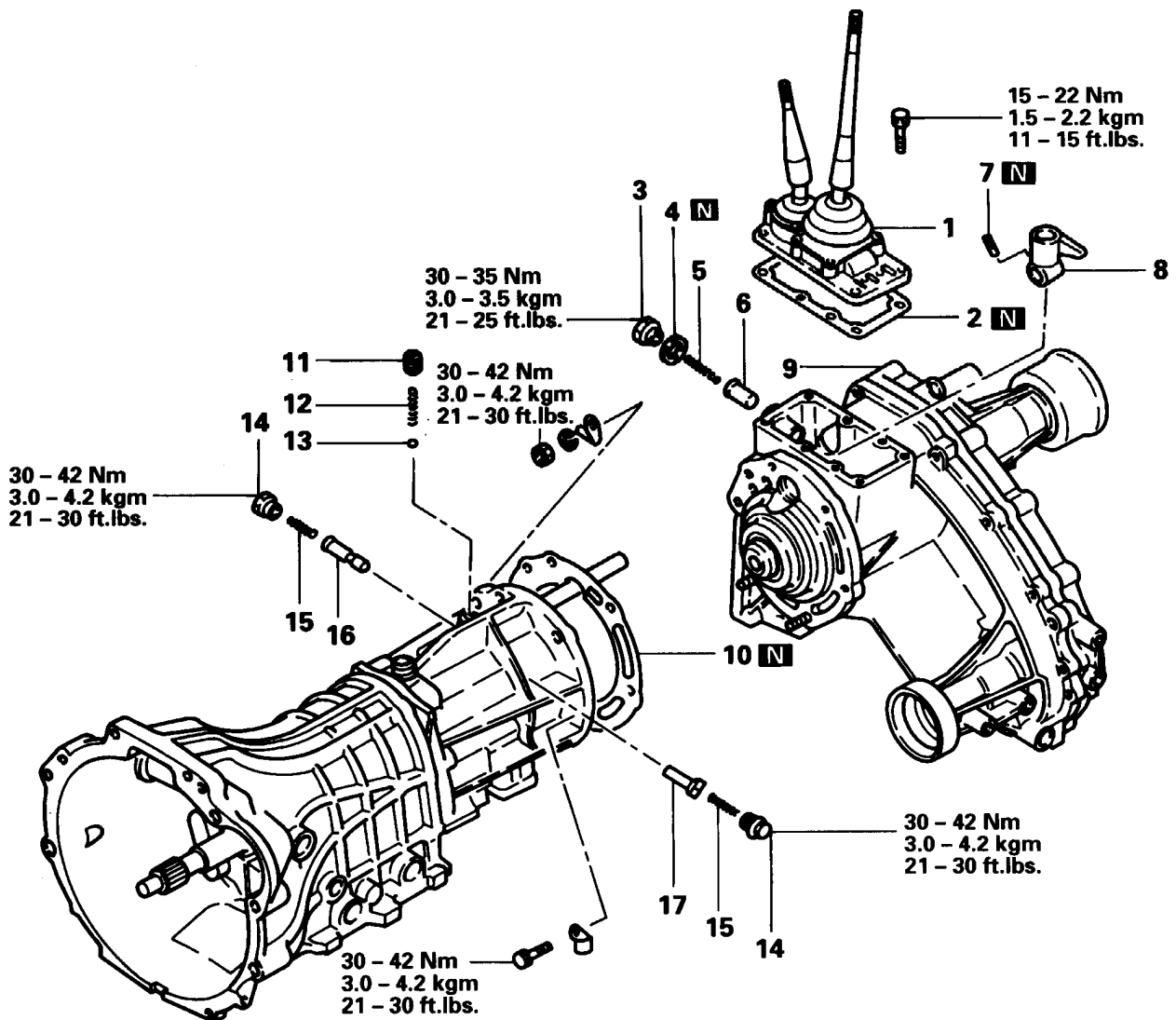
**Disassembly steps**

1. Control lever assembly
2. Gasket
3. Select plunger plug
4. Gasket
5. Select spring
6. Select plunger
- ① I 7. Spring pin
8. Change shifter
9. Transfer case assembly
- Ⓚ 10. Adapter gasket
- Ⓢ 11. Plug
12. Spring
13. Steel ball
- Ⓡ 14. Seal plug
15. Neutral return spring
- Ⓚ 16. Neutral return plunger (B)
- Ⓚ 17. Neutral return plunger (A)

TRM0077

V5M21-1-G, J, Q, V5M21-4-Q (KM145-8, 9, B, D)

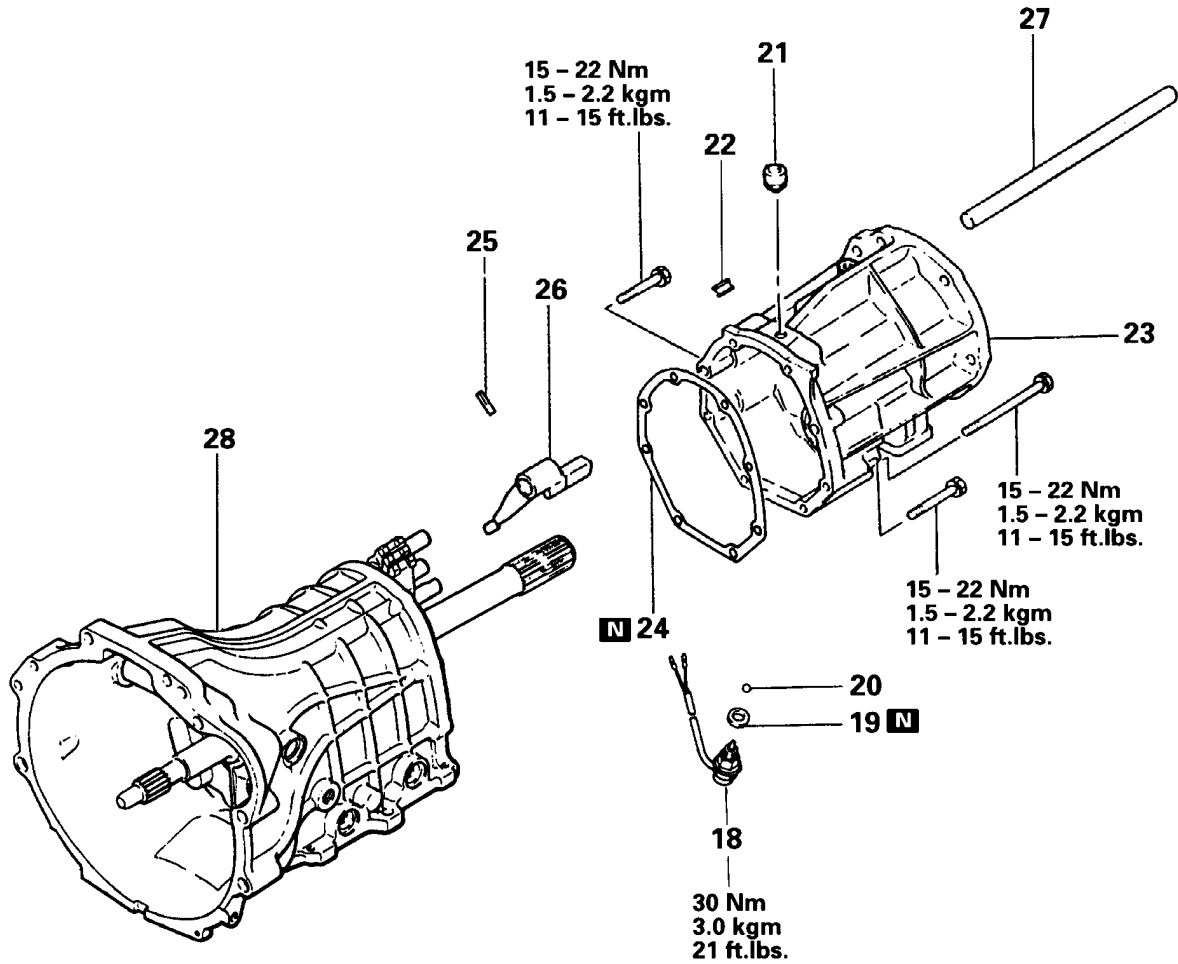

Disassembly steps

- 18. Backup lamp switch
- 19. Gasket
- 20. Steel ball
- 21. Breather
- 22. Plug
- 23. Transfer adapter ←
- 24. Case gasket ←
- 25. Lock pin ←
- 26. Control finger ←
- 27. Control shaft ←
- 28. Transmission assembly

Caution
The control finger and control shaft should be left installed in the transfer adapter as the lock pin cannot be removed. If any of these four parts requires replacement, order them all and replace them as a unit.

V5M21-1-G, J, Q, V5M21-4-Q (KM145-8, 9, B, D)

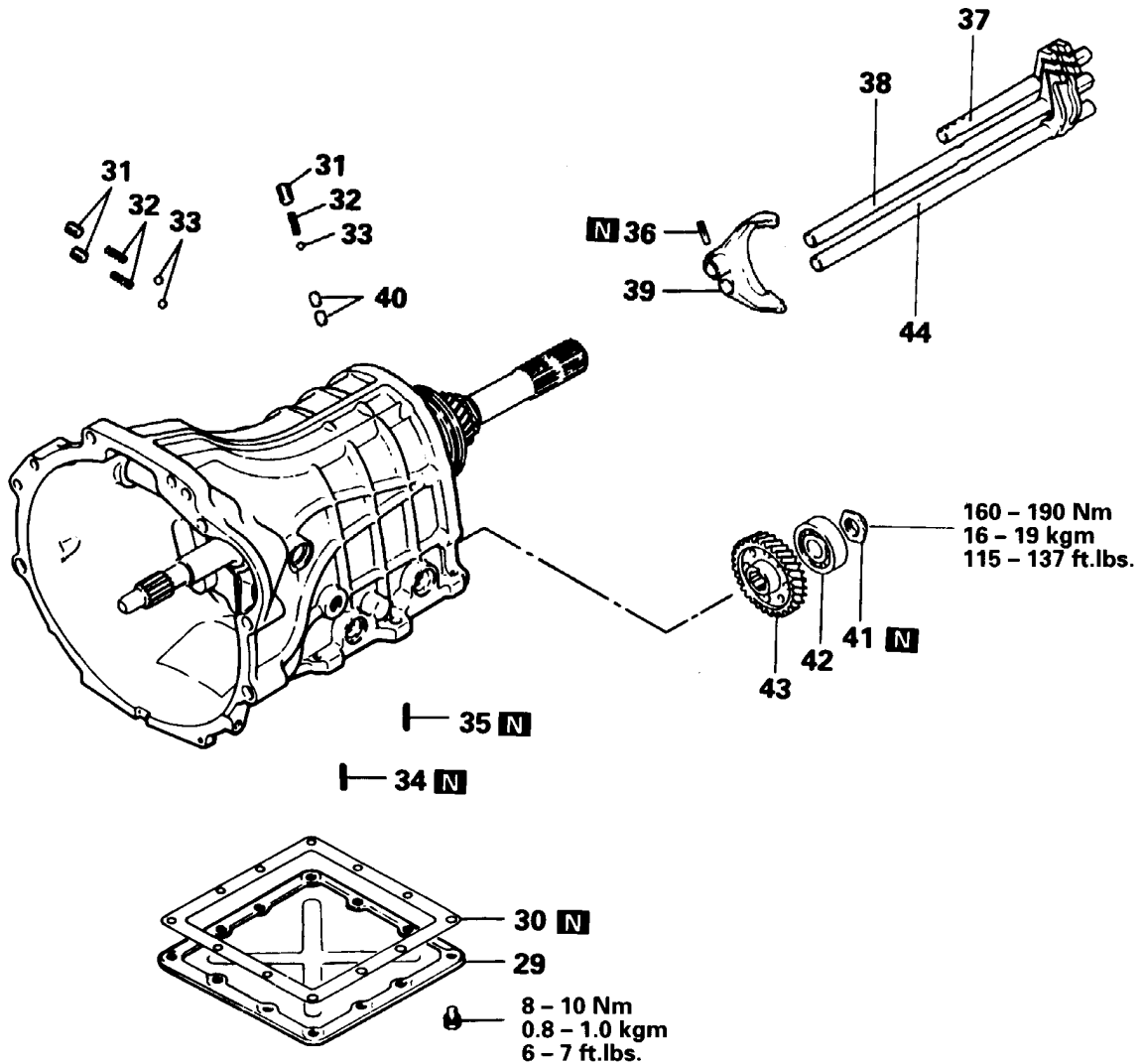
**Disassembly steps**

- 29. Under cover
- 30. Under cover gasket
- 31. Poppet plug
- b** 32. Poppet spring
- b** 33. Steel ball
- Y** 34. Spring pin for 3rd-4th speed shift fork
- Y** 35. Spring pin for 1st-2nd speed shift fork
- X** 36. Spring pin for OD-R shift fork
- 37. OD-R shift rail
- 38. 3rd-4th speed shift rail
- 39. OD-R shift fork
- 40. Interlock plunger
- V** 41. Countershaft lock nut
- U** 42. Countershaft rear bearing
- 43. Counter overdrive gear
- 44. 1st-2nd speed shift rail

V5M21-1-G, J, Q, V5M21-4-Q (KM145-8, 9, B, D)

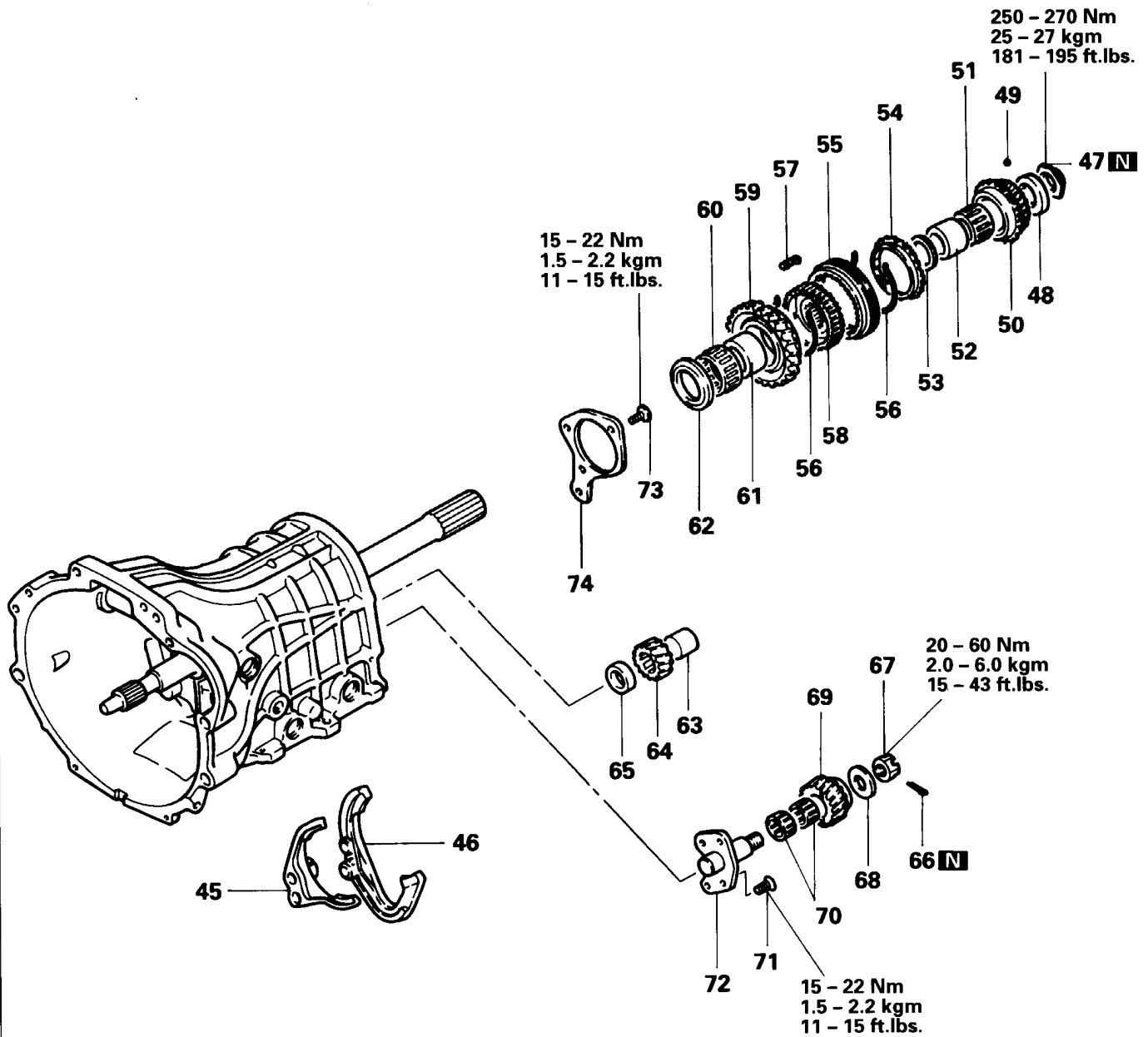

Disassembly steps

- 45. 3rd-4th speed shift fork
- 46. 1st-2nd speed shift fork
- (E) (S) 47. Mainshaft lock nut
- 48. Spacer
- 49. Steel ball
- 50. Overdrive gear
- 51. Needle bearing
- (F) (R) 52. Bearing sleeve
- 53. Bearing spacer
- (Q) 54. Overdrive synchronizer ring
- (O) 55. OD-R synchronizer sleeve
- (P) 56. OD-R synchronizer spring
- (O) 57. OD-R synchronizer key
- 58. OD-R synchronizer hub
- 59. Reverse gear

- 60. Needle bearing
- (N) 61. Reverse gear bearing sleeve
- 62. Spacer
- 63. Spacer
- 64. Counter reverse gear
- 65. Spacer
- 66. Split pin
- 67. Slotted nut
- 68. Thrust washer
- 69. Reverse idler gear
- 70. Needle bearing
- (L) 71. Bolt
- (G) (L) 72. Reverse idler gear shaft
- (K) 73. Bolt
- 74. Rear bearing retainer

TRM0082

V5M21-1-G, J, Q, V5M21-4-Q (KM145-8, 9, B, D)

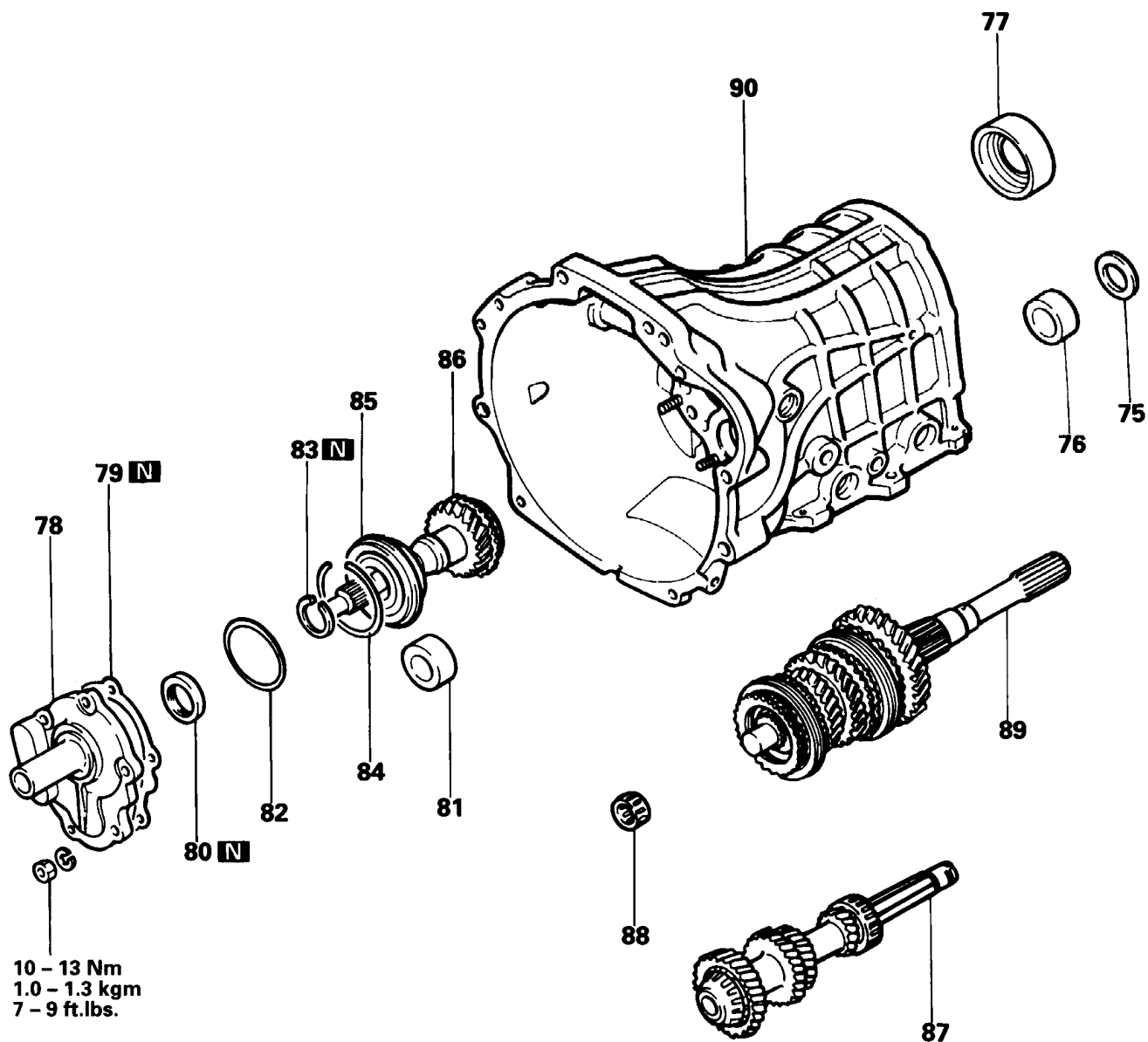
**Disassembly steps**

- J** 75. Spacer
- 76. Countershaft center bearing outer race
- 77. Mainshaft bearing outer race
- 78. Front bearing retainer
- G** 79. Front bearing retainer gasket
- E** 80. Oil seal
- 81. Countershaft front bearing outer race
- F** 82. Spacer
- C** 83. Snap ring
- 84. Snap ring
- K** **B** 85. Maindrive gear bearing
- 86. Maindrive gear
- 87. Counter gear assembly
- 88. Mainshaft front bearing
- 89. Mainshaft assembly
- 90. Transmission case

TRM0087

V5M21-2-E (KM147-3, 6)

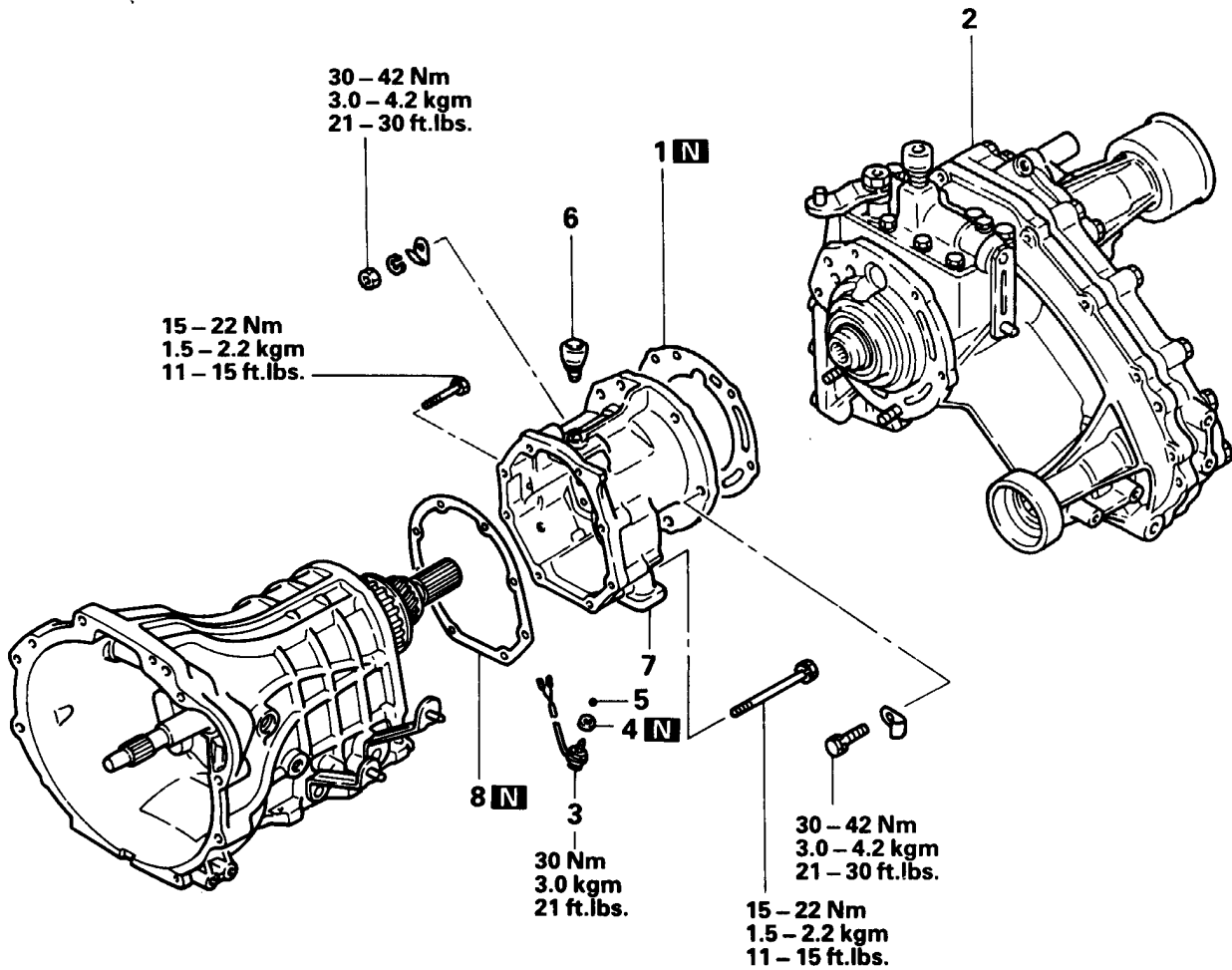

Disassembly steps

- k** 1. Adapter gasket
- 2. Transfer assembly
- 3. Backup lamp switch
- 4. Gasket
- 5. Steel ball
- j** 6. Breather
- i** 7. Transfer adapter
- h** 8. Case gasket

V5M21-2-E (KM147-3, 6)

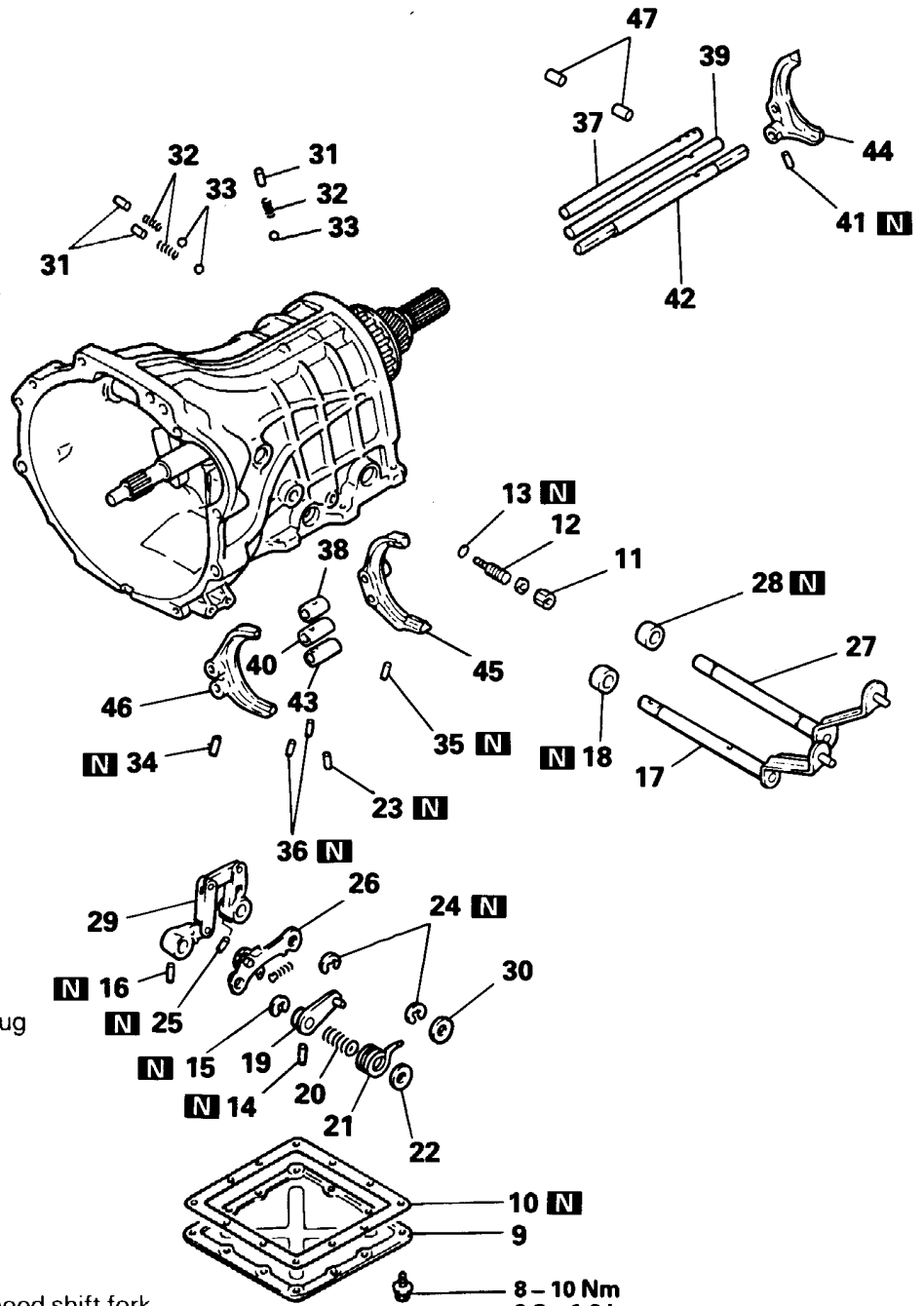

Disassembly steps

- 9. Under cover
- 10. Under cover gasket
- 11. Nut
- W** 12. Select adjuster
- 13. O-ring
- M** **b** 14. Spring pin
- N** **d** 15. Snap ring
- N** **d** 16. Spring pin
- 17. Select shaft
- 18. Oil seal
- 19. Adjust arm
- 20. Distance spring
- 21. Return spring
- 22. Spacer
- C** **b** 23. Spring pin for OD-R shift lug
- P** **c** **f** 24. Snap ring
- P** **c** **f** 25. Lock pin
- 26. Stopper bracket
- 27. Shift shaft
- 28. Oil seal
- 29. Control rink
- 30. Spacer
- 31. Poppet plug
- b** 32. Poppet spring
- b** 33. Steel ball
- C** **Y** 34. Spring pin for 3rd – 4th speed shift fork
- C** **Y** 35. Spring pin for 1st – 2nd speed shift fork
- C** **Z** 36. Spring pin for 3rd – 4th speed shift lug and 1st – 2nd speed shift lug
- 37. 1st – 2nd speed shift rail
- 38. 1st – 2nd speed shift lug
- 39. 3rd – 4th speed shift rail
- 40. 3rd – 4th speed shift lug
- D** **x** 41. Spring pin for OD – R shift fork
- 42. OD-R shift rail
- 43. OD-R shift lug
- 44. OD-R shift fork
- 45. 1st – 2nd speed shift fork
- 46. 3rd – 4th speed shift fork
- 47. Interlock plunger

8 – 10 Nm
0.8 – 1.0 kgm
6 – 7 ft.lbs.

V5M21-2-E (KM147-3, 6)

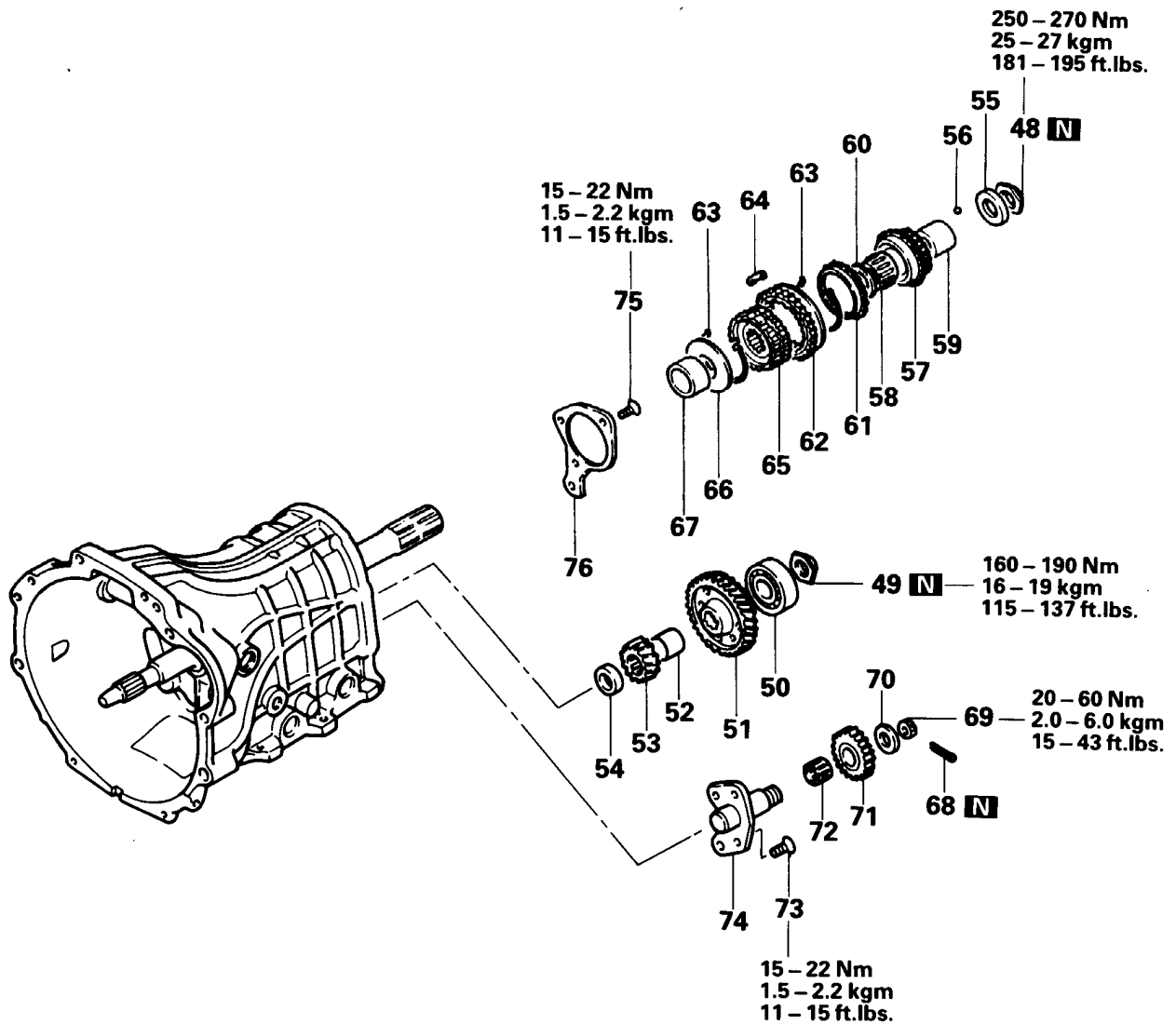

Disassembly steps

- ④ **S** 48. Mainshaft lock nut
- V** 49. Countershaft lock nut
- U** 50. Countershaft rear bearing
- 51. Counter overdrive gear
- 52. Spacer
- 53. Counter reverse gear
- 54. Spacer
- 55. Spacer
- 56. Steel ball
- 57. Overdrive gear
- 58. Needle bearing
- ④ **R** 59. Bearing sleeve
- Q** 60. Bearing spacer
- Q** 61. OD-R synchronizer ring
- P** 62. OD-R synchronizer sleeve
- P** 63. Overdrive synchronizer spring
- P** 64. OD-R synchronizer key
- O** 65. OD-R synchronizer hub

- 66. Stopper plate
- 67. Spacer
- 68. Split pin
- 69. Slotted nut
- 70. Thrust washer
- 71. Reverse idler gear
- 72. Needle bearing
- 73. Bolt
- ④ **L** 74. Reverse idler gear shaft
- K** 75. Bolt
- 76. Rear bearing retainer

V5M21-2-E (KM147-3, 6)

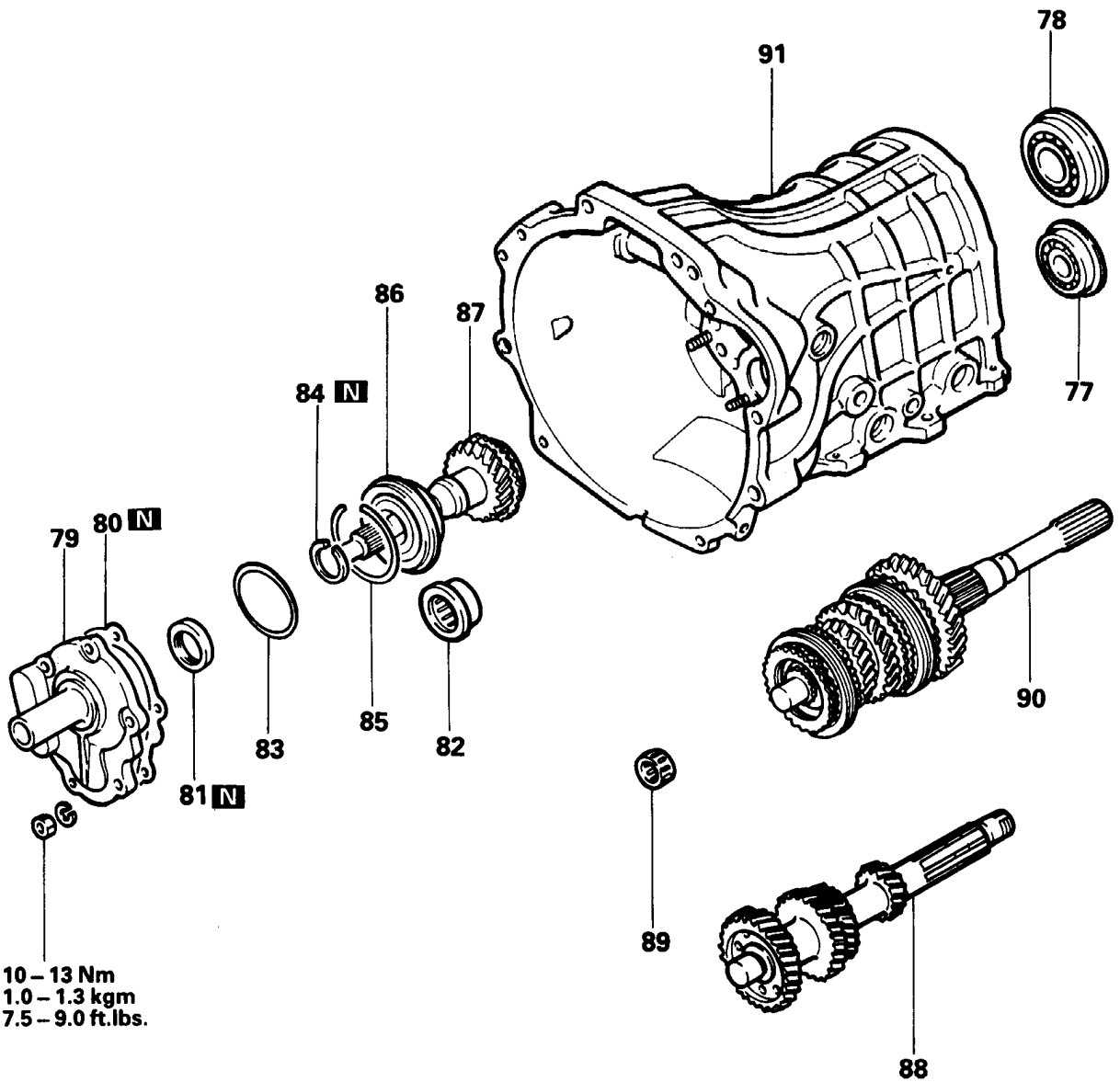

Disassembly steps

- (H) (I) 77. Countershaft center bearing
- (I) (H) 78. Mainshaft bearing
- (I) (H) 79. Front bearing retainer
- (I) (H) (G) 80. Front bearing retainer gasket
- (I) (H) (G) 81. Oil seal
- (J) (I) (H) (G) 82. Countershaft front bearing
- (J) (I) (H) (G) 83. Spacer
- (J) (I) (H) (G) 84. Snap ring
- (J) (I) (H) (G) 85. Snap ring
- (K) (I) (H) (G) 86. Maindrive gear bearing
- (K) (I) (H) (G) 87. Maindrive gear
- (K) (I) (H) (G) 88. Countershaft
- (K) (I) (H) (G) 89. Mainshaft front bearing
- (K) (I) (H) (G) 90. Mainshaft assembly
- (K) (I) (H) (G) 91. Transmission case

V5M21-2-Q, G (KM147-5, 7)

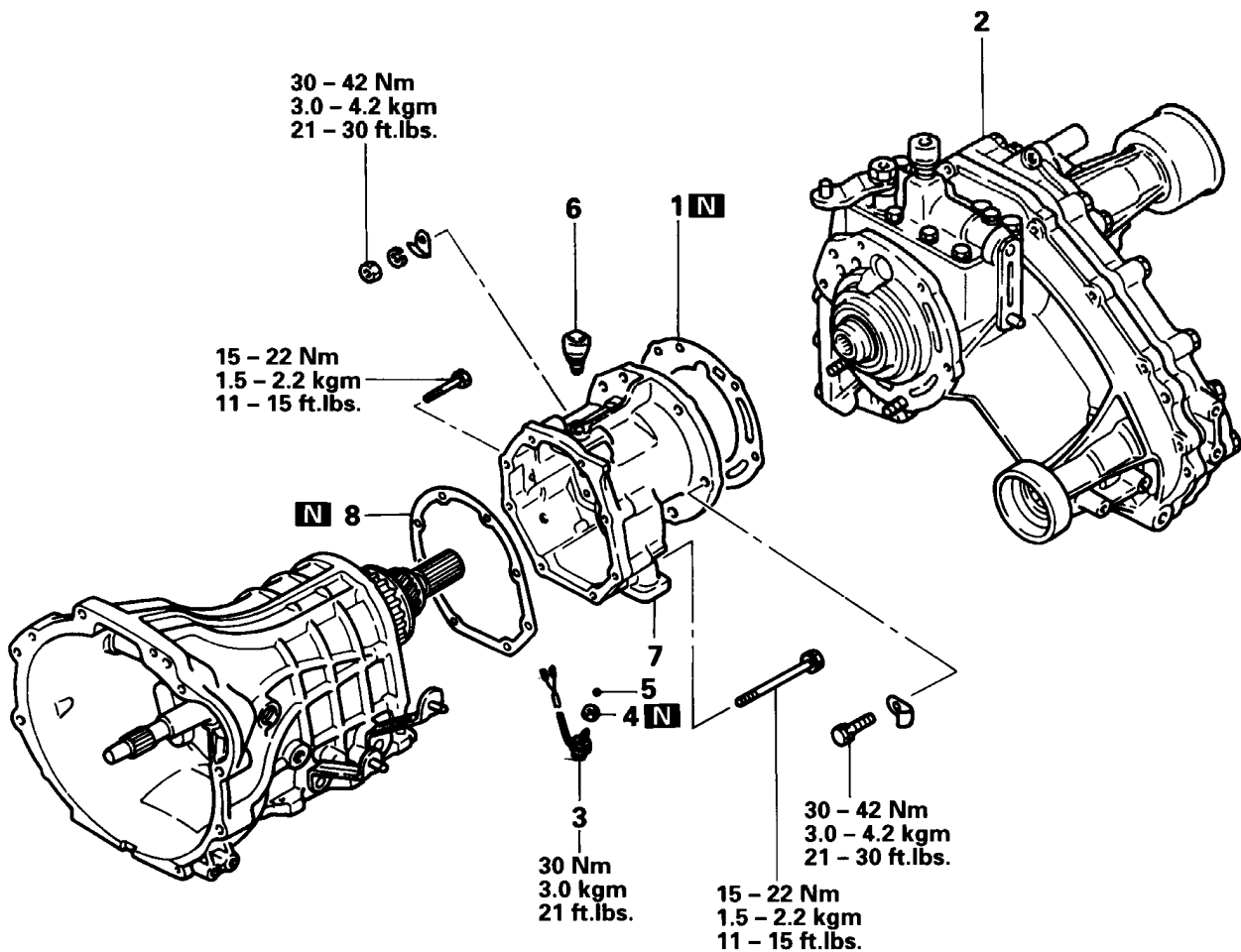

Disassembly steps

- [k] 1. Adapter gasket
- 2. Transfer assembly
- 3. Backup lamp switch
- 4. Gasket
- 5. Steel ball
- [j] 6. Breather
- [i] 7. Transfer adapter
- [h] 8. Case gasket

V5M21-2-Q, G (KM147-5, 7)

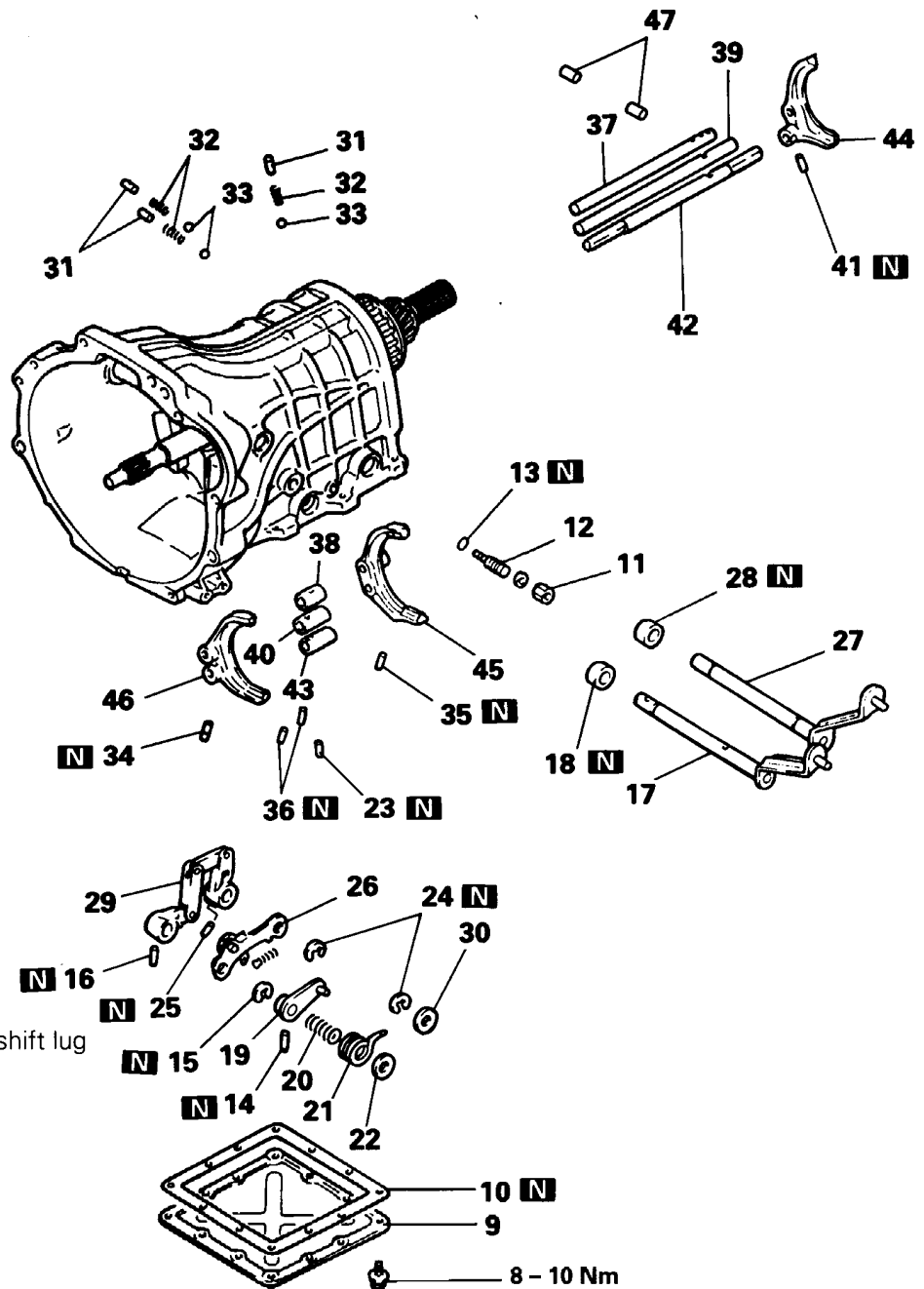

Disassembly steps

- 9. Under cover
- 10. Under cover gasket
- 11. Nut
- W 12. Select adjuster
- M 13. O-ring
- e 14. Spring pin
- n 15. Snap ring
- d 16. Spring pin
- N 17. Select shaft
- 18. Oil seal
- 19. Adjust arm
- 20. Distance spring
- 21. Return spring
- 22. Spacer
- C a 23. Spring pin for OD-R shift lug
- m 24. Snap ring
- P c 25. Lock pin
- 26. Stopper bracket
- 27. Shift shaft
- 28. Oil seal
- 29. Control link
- 30. Spacer
- b 31. Poppet plug
- b 32. Poppet spring
- b 33. Steel ball
- C Y 34. Spring pin for 3rd-4th speed shift fork
- C Y 35. Spring pin for 1st-2nd speed shift fork
- Q Z 36. Spring pin for 3rd-4th speed shift lug and 1st-2nd speed shift lug
- 37. 1st-2nd speed shift rail
- 38. 1st-2nd speed shift lug
- 39. 3rd-4th speed shift rail
- 40. 3rd-4th speed shift lug
- D X 41. Spring pin for OD-R shift fork
- 42. OD-R shift rail
- 43. OD-R shift lug
- 44. OD-R shift fork
- 45. 1st-2nd speed shift fork
- 46. 3rd-4th speed shift fork
- 47. Interlock plunger

8 - 10 Nm
0.8 - 1.0 kgm
6 - 7 ft. lbs.

V5M21-2-Q, G (KM147-5, 7)

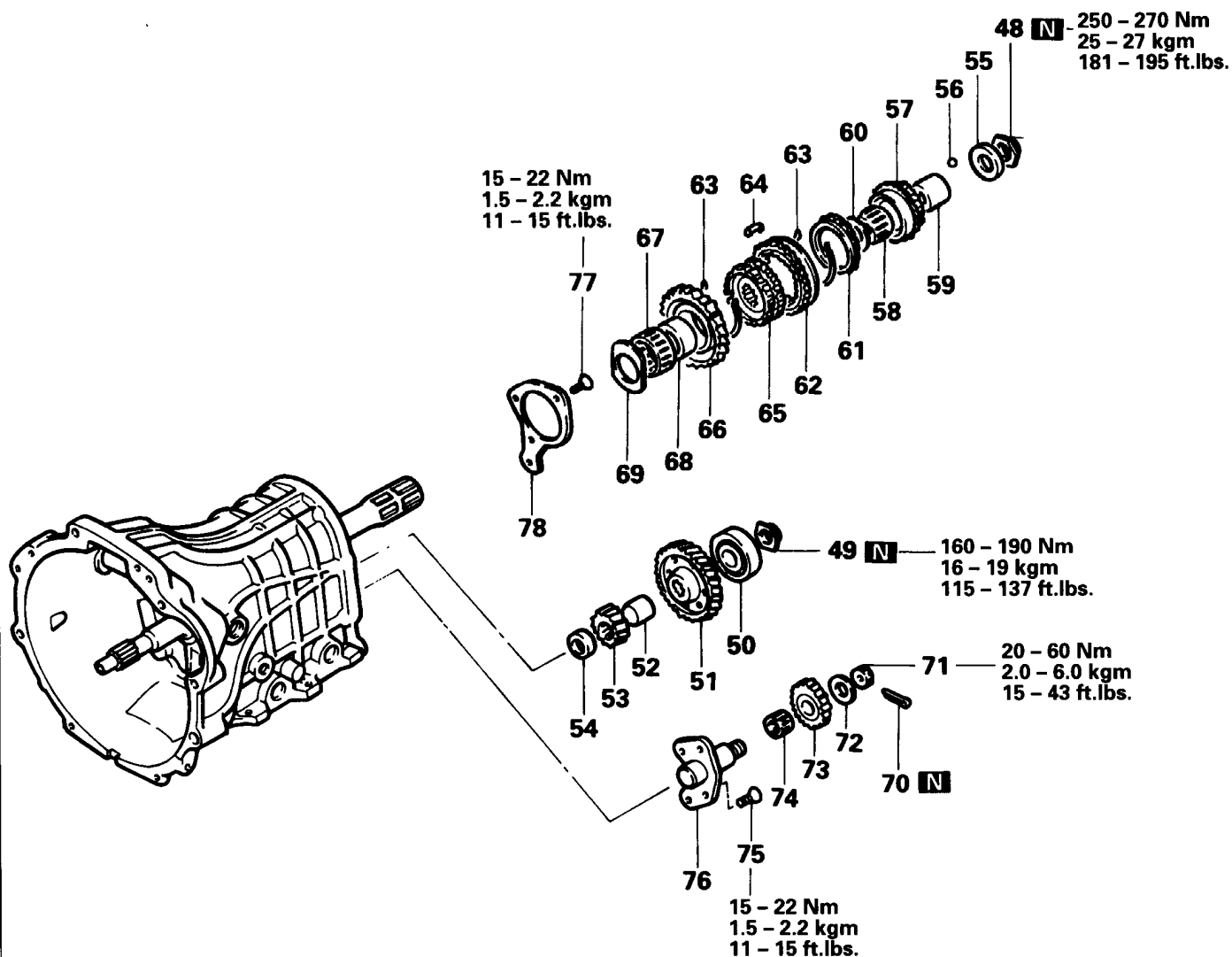

Disassembly steps

- Ⓔ **S** 48. Mainshaft lock nut
- Ⓔ **V** 49. Countershaft lock nut
- Ⓔ **U** 50. Countershaft rear bearing
- 51. Counter overdrive gear
- 52. Spacer <V5M21-2-Q (KM147-5, 7)>
- 53. Counter reverse gear
- 54. Spacer
- 55. Spacer
- 56. Steel ball
- 57. Overdrive gear
- 58. Needle bearing
- Ⓕ **R** 59. Bearing sleeve
- 60. Bearing spacer
- Ⓖ **Q** 61. OD-R synchronizer ring
- Ⓖ **O** 62. OD-R synchronizer sleeve
- Ⓖ **P** 63. Overdrive synchronizer spring
- Ⓖ **P** 64. OD-R synchronizer key
- Ⓖ **O** 65. OD-R synchronizer hub
- 66. Reverse gear
- 67. Needle bearing
- Ⓖ **N** 68. Bearing sleeve
- 69. Spacer
- 70. Split pin
- 71. Slotted nut
- 72. Thrust washer
- 73. Reverse idler gear
- 74. Needle bearing
- Ⓖ **L** 75. Bolt
- Ⓖ **L** 76. Reverse idler gear shaft
- Ⓖ **K** 77. Bolt
- 78. Rear bearing retainer

V5M21-5, V5M21-6-Q, R, G, V5M21-7-G, Q, V5M21-9-G

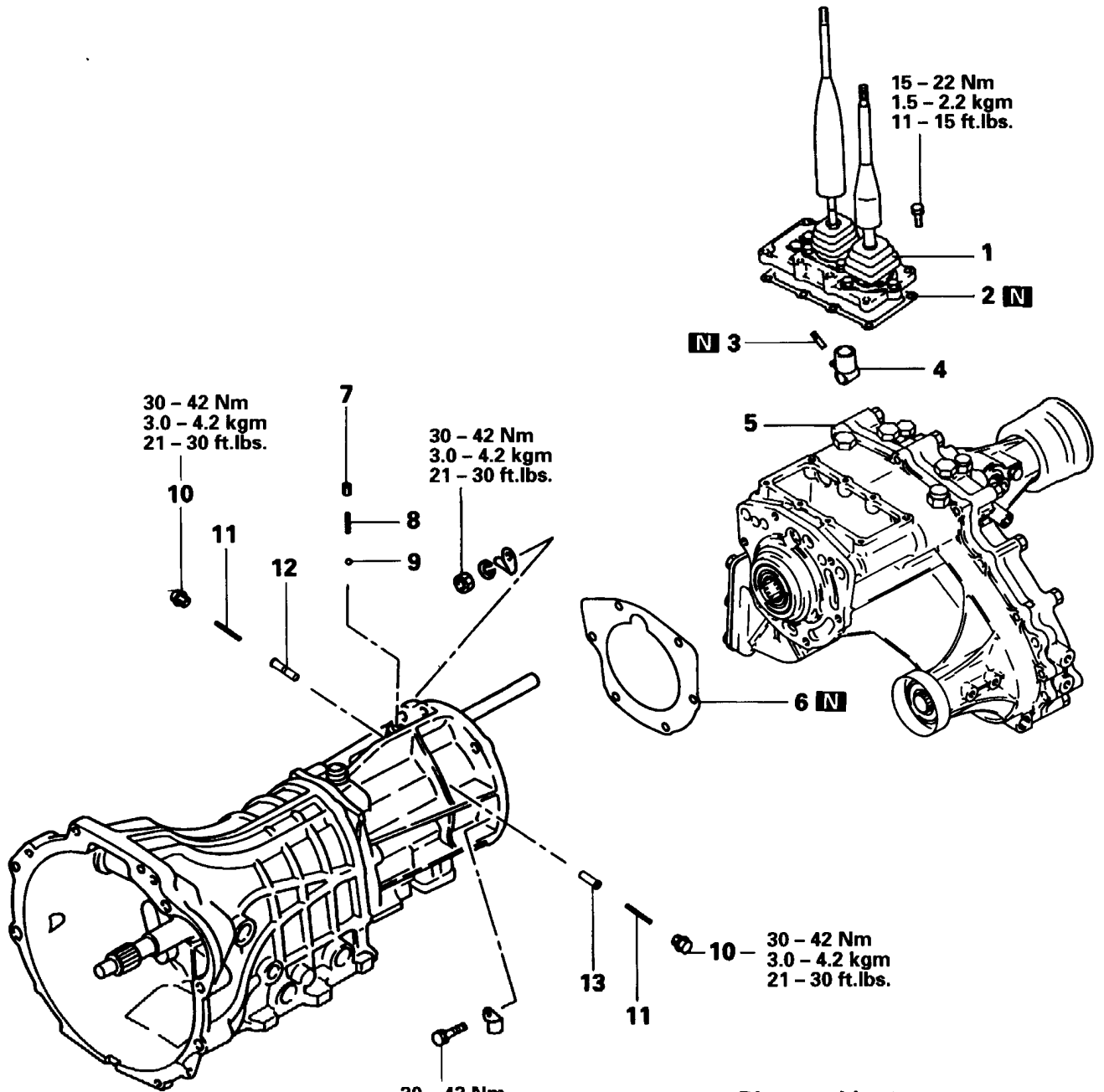

Disassembly steps

1. Control lever assembly
2. Gasket
- (A) (I) 3. Spring pin
4. Change shifter
5. Transfer assembly
- (k) (s) 6. Adapter gasket
7. Plug
8. Spring
- (r) 9. Steel ball
- (q) 10. Seal plug
11. Neutral return spring
- (q) 12. Neutral return plunger (B)
- (q) 13. Neutral return plunger (A)

TRM0252

V5M21-5, V5M21-6-Q, R, G, V5M21-7-G, Q, V5M21-9-G

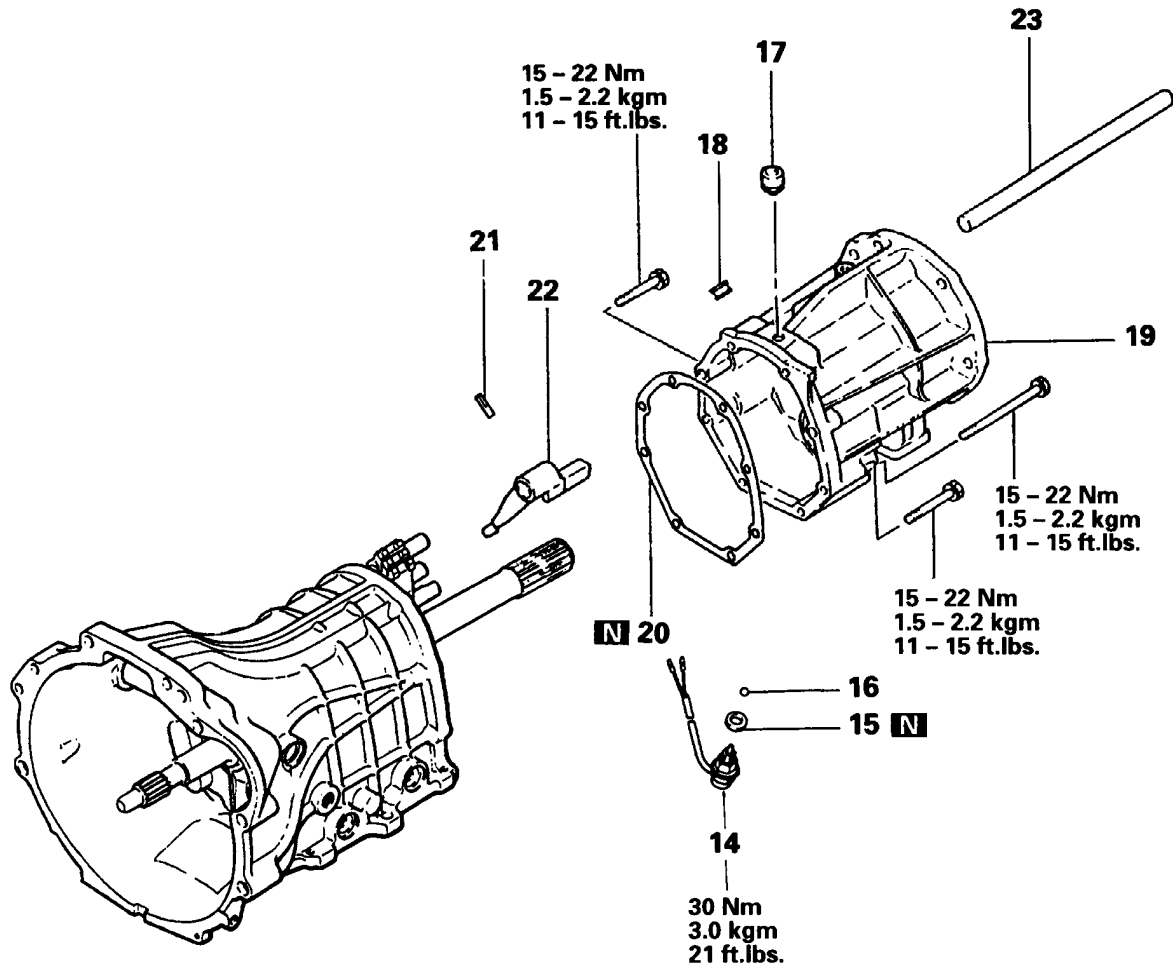

Disassembly steps

- 14. Backup lamp switch
- 15. Gasket
- 16. Steel ball
- 17. Breather
- 18. Plug
- 19. Transfer adapter
- 20. Case gasket
- 21. Lock pin
- 22. Control finger
- 23. Control shaft

Caution
The control finger and control shaft should be left installed in the transfer adapter as the lock pin cannot be removed. If any of these four parts requires replacement, order them all and replace them as a unit.

V5M21-5, V5M21-6-O, R, G, V5M21-7-G, O, V5M21-9-G

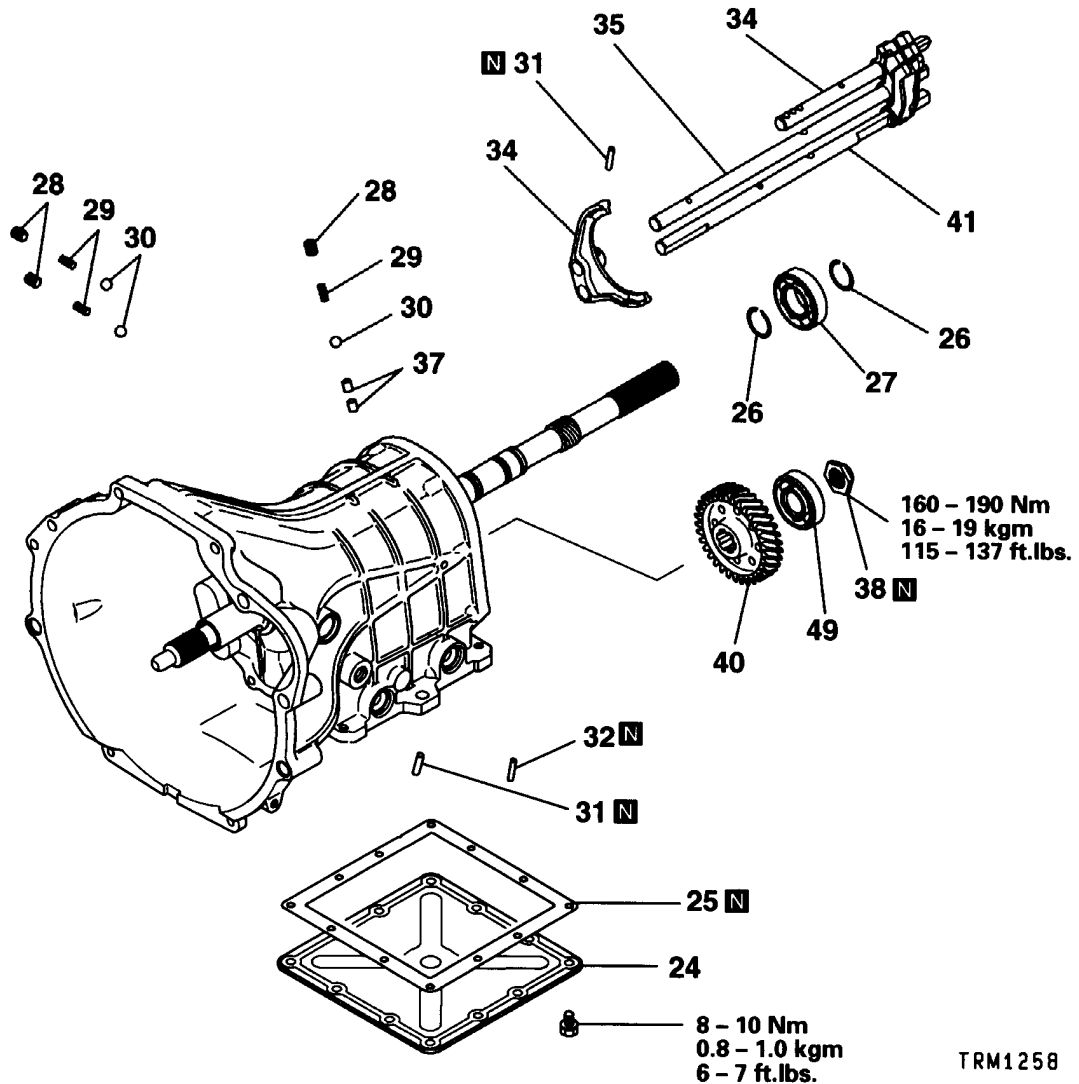

TRM1258

Disassembly steps

- 24. Under cover
- 25. Under cover gasket
- P** 26. Snap ring (V5M21-6-G only)
- P** 27. Mainshaft rear bearing (V5M21-6-G only)
- 28. Poppet plug
- b** 29. Poppet spring
- b** 30. Steel ball
- Y** 31. Spring pin for 3rd-4th speed shift fork
- Y** 32. Spring pin for 1st-2nd speed shift fork
- X** 33. Spring pin for OD-R shift fork
- 34. OD-R shift rail
- 35. 3rd-4th speed shift rail
- 36. OD-R shift fork
- 37. Interlock plunger
- V** 38. Countershaft lock nut
- U** 39. Countershaft rear bearing
- 40. Counter overdrive gear
- 41. 1st-2nd speed shift rail

V5M21-5, V5M21-6-Q, R, G, V5M21-7-G, Q, V5M21-9-G

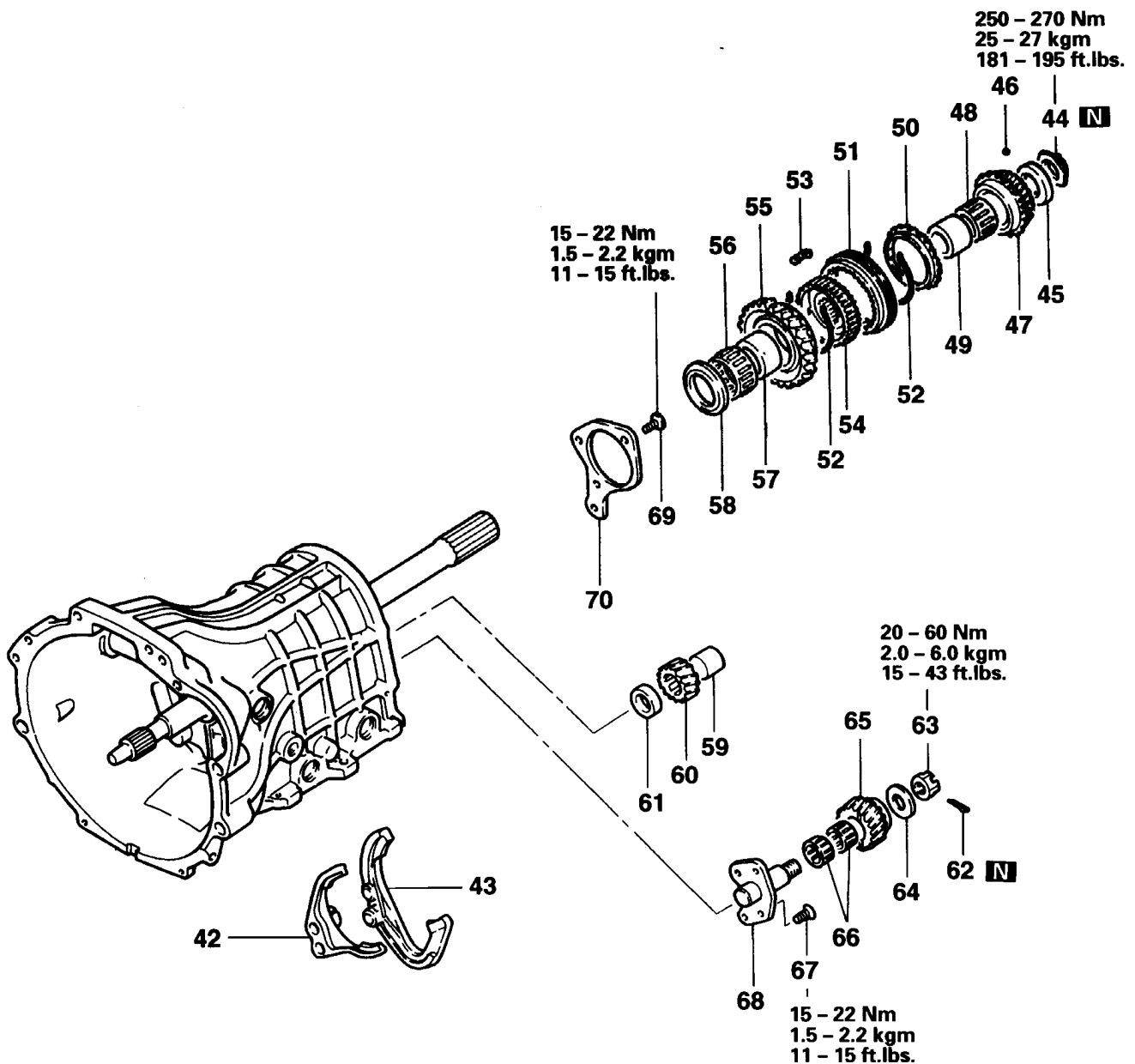

Disassembly steps

- 42. 3rd-4th speed shift fork
- 43. 1st-2nd speed shift fork
- (E) (S) 44. Mainshaft lock nut
- 45. Spacer
- 46. Steel ball
- 47. Overdrive gear
- 48. Needle bearing
- (F) (R) 49. Bearing sleeve
- (Q) 50. Overdrive synchronizer ring
- (O) 51. OD-R synchronizer sleeve
- (P) 52. OD-R synchronizer spring
- (P) 53. OD-R synchronizer key
- (O) 54. OD-R synchronizer hub
- 55. Reverse gear

- (N) 56. Needle bearing
- (N) 57. Reverse gear bearing sleeve
- 58. Spacer <except V5M21-6-G, V5M21-7-G, V5M21-9-G>
- 59. Spacer <V5M21-5>
- 60. Counter reverse gear
- 61. Spacer
- 62. Split pin
- 63. Slotted nut
- 64. Thrust washer
- 65. Reverse idler gear
- 66. Needle bearing
- (M) 67. Bolt
- (G) (L) 68. Reverse idler gear shaft
- (K) 69. Bolt
- 70. Rear bearing retainer

V5M21-5, V5M21-6-O, R, G, V5M21-7-G, O, V5M21-9-G

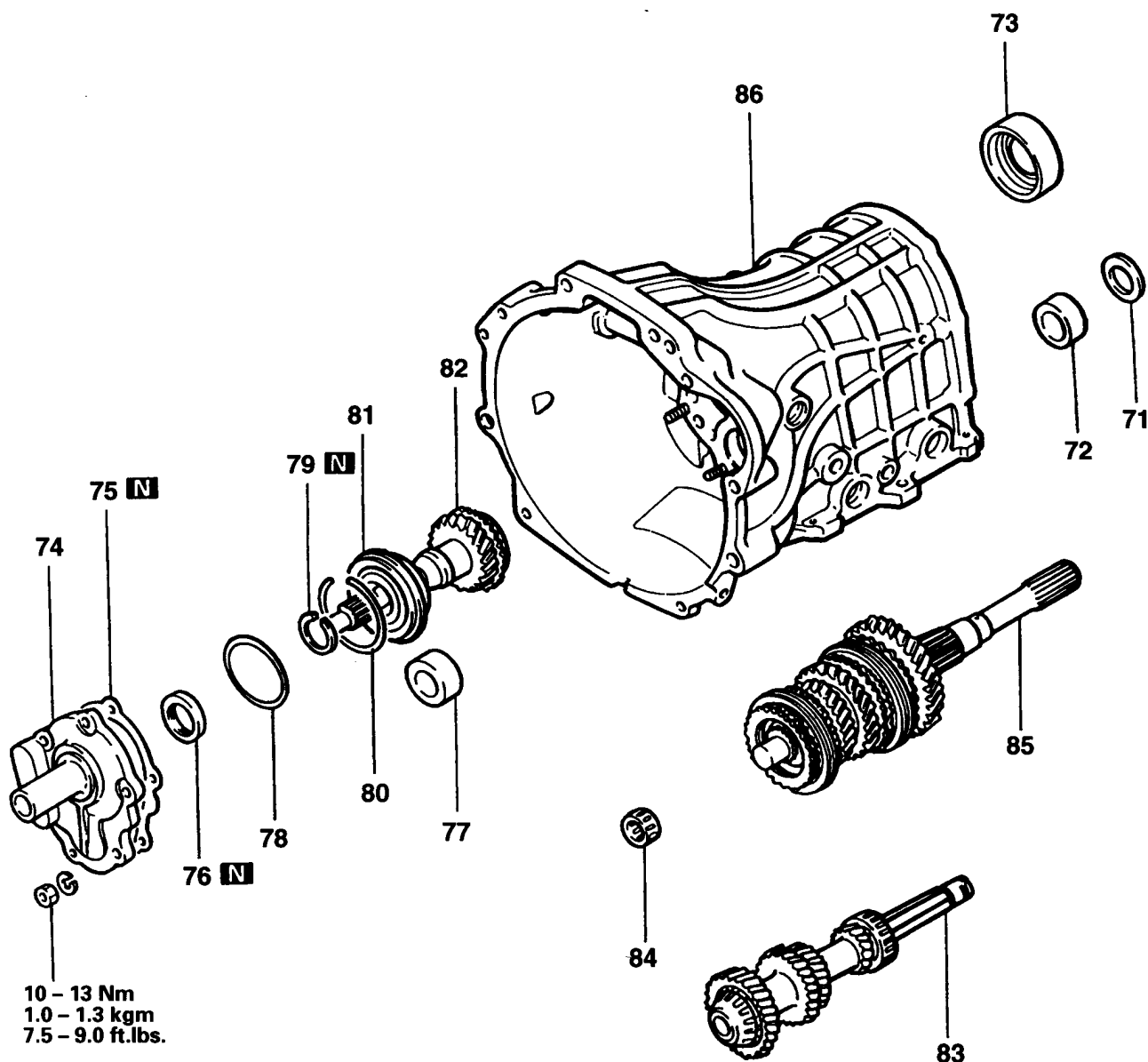

Disassembly steps

- Ⓝ 71. Spacer
- 72. Countershaft center bearing outer race
- 73. Mainshaft bearing outer race
- 74. Front bearing retainer
- Ⓜ 75. Front bearing retainer gasket
- Ⓝ 76. Oil seal
- 77. Countershaft front bearing outer race
- Ⓜ 78. Spacer
- Ⓝ 79. Snap ring
- 80. Snap ring
- Ⓝ Ⓜ 81. Maindrive gear bearing
- 82. Maindrive gear
- 83. Counter gear assembly
- 84. Mainshaft front bearing
- 85. Mainshaft assembly
- 86. Transmission case

V5M21-7-E

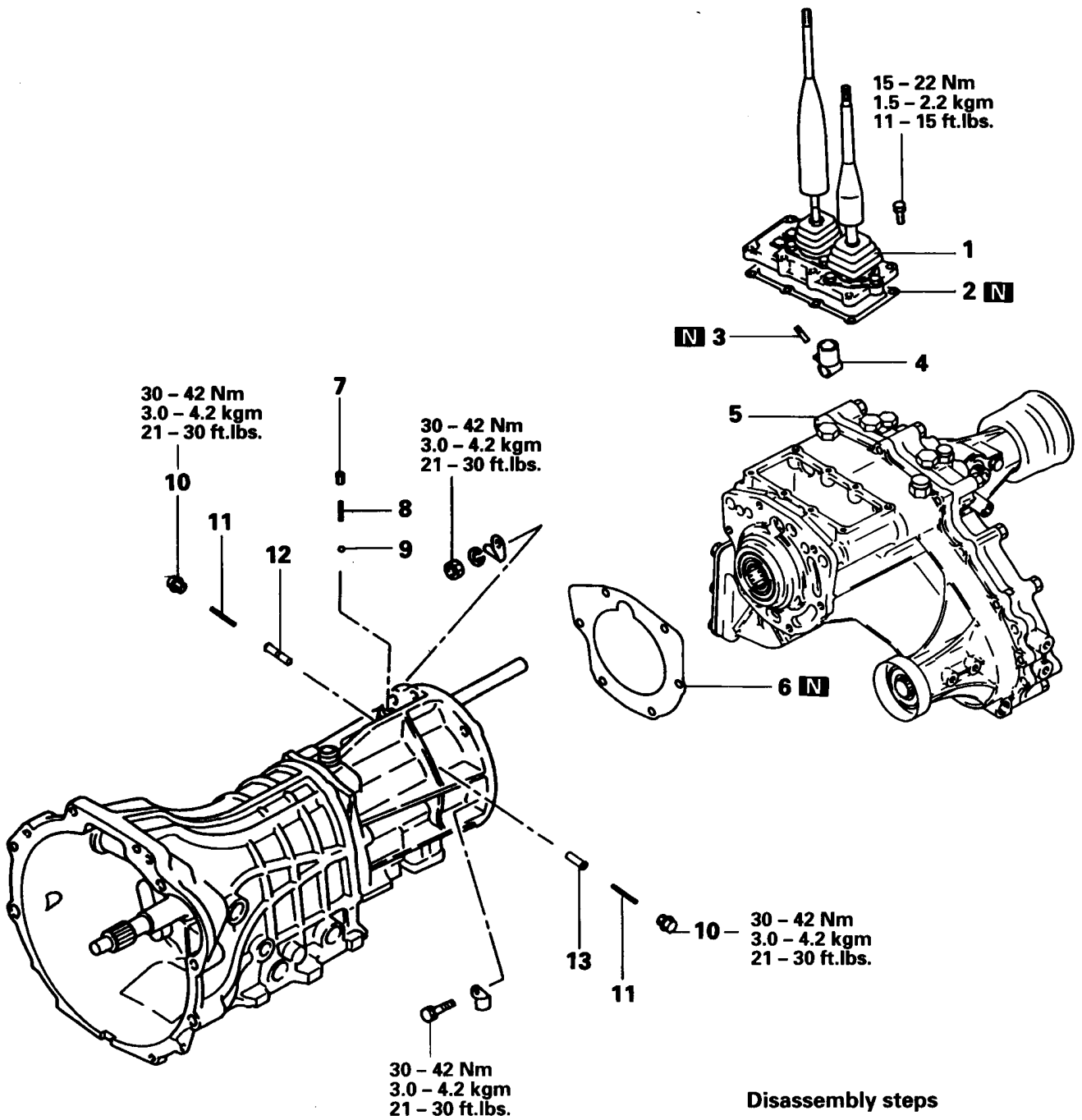

Disassembly steps

1. Control lever assembly
2. Gasket
- (A) (I) 3. Spring pin
4. Change shifter
5. Transfer assembly
- (k) (s) 6. Adapter gasket
7. Plug
8. Spring
9. Steel ball
- (r) 10. Seal plug
11. Neutral return spring
- (q) 12. Neutral return plunger (B)
- (q) 13. Neutral return plunger (A)

TRM0252

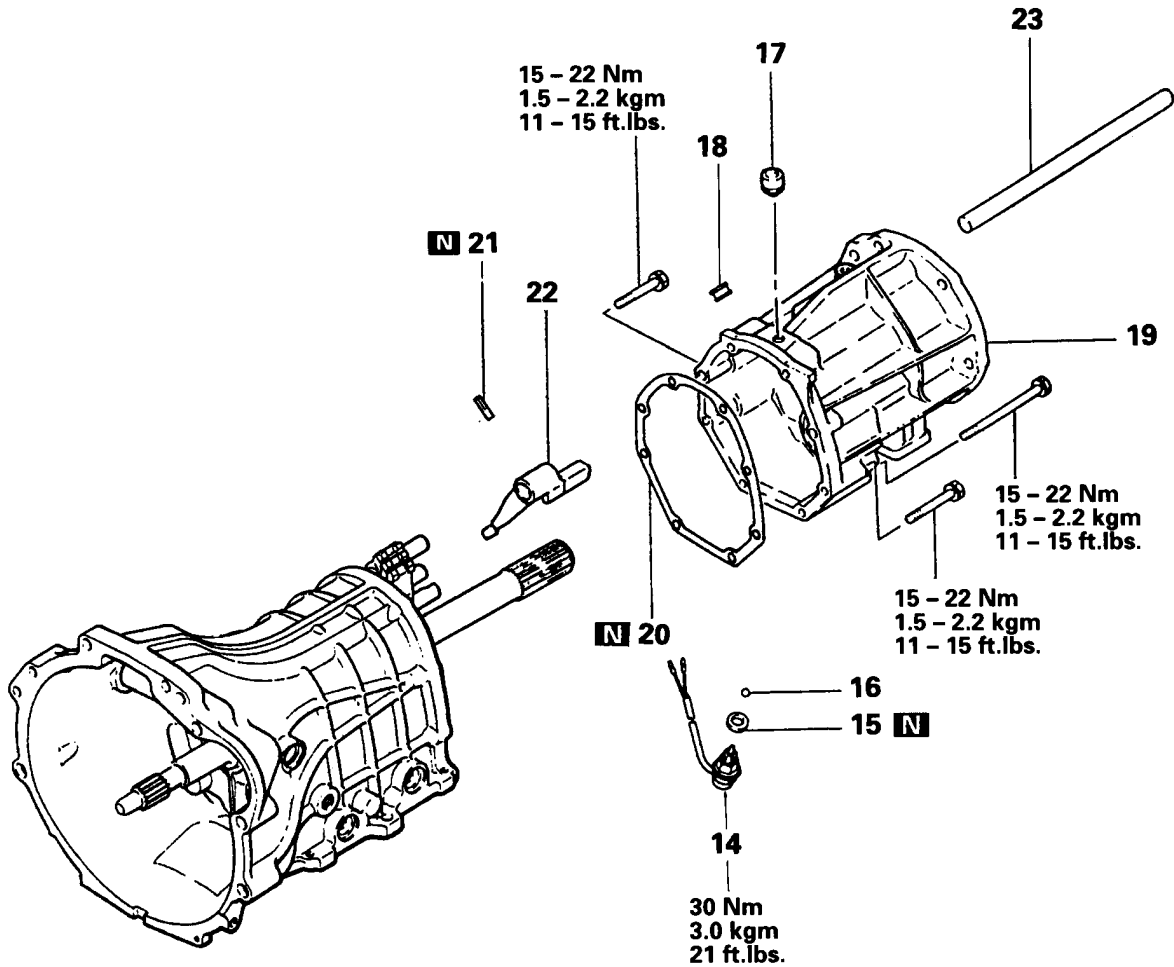

Disassembly steps

- 14. Backup lamp switch
- 15. Gasket
- 16. Steel ball
- i 17. Breather
- 18. Plug
- B i 19. Transfer adapter
- h 20. Case gasket
- 21. Lock pin
- 22. Control finger
- 23. Control shaft

V5M21-7-E

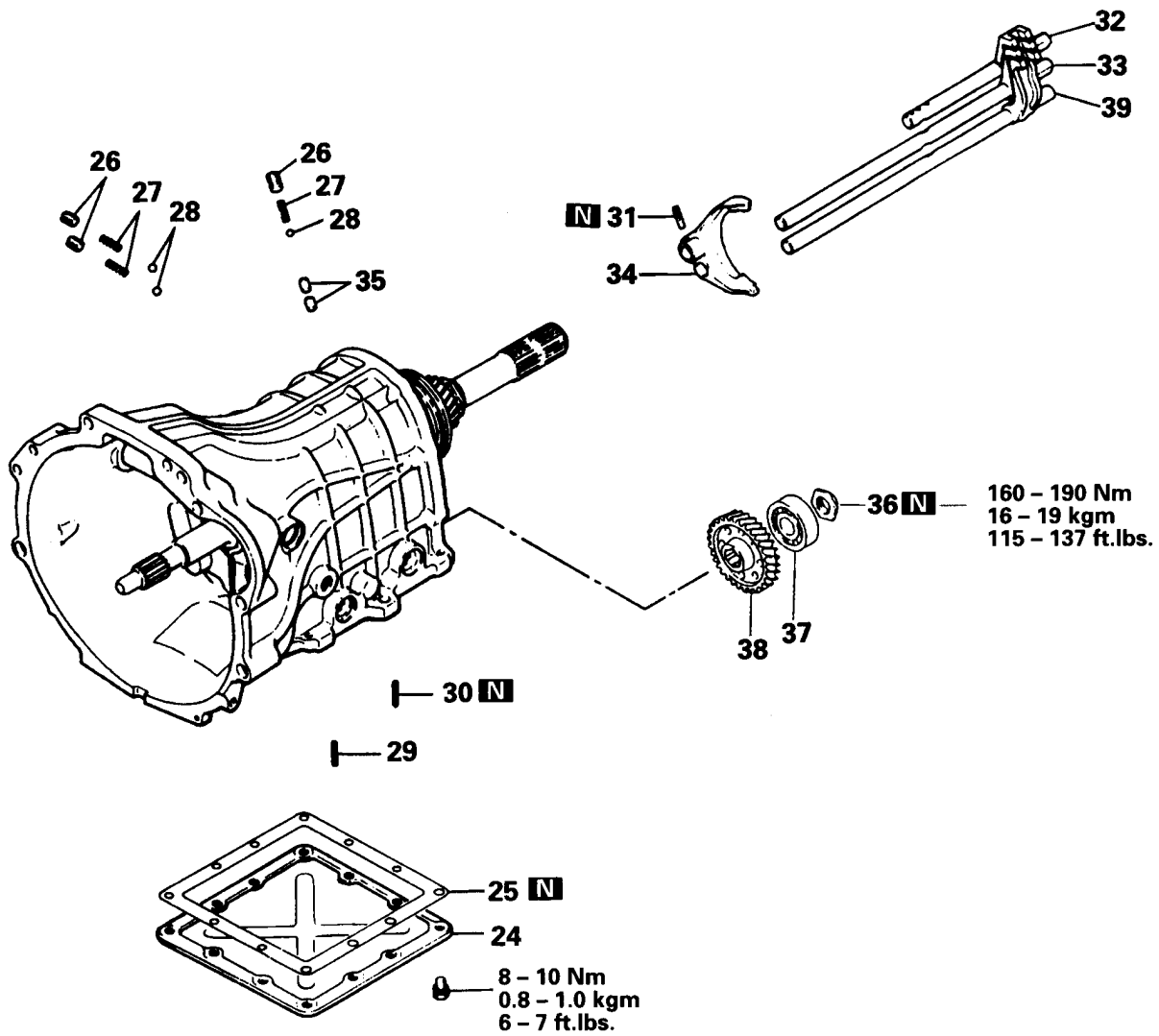

Disassembly steps

- 24. Under cover
- 25. Under cover gasket
- 26. Poppet plug
- 27. Poppet spring
- 28. Steel ball
- 29. Spring pin for 3rd-4th speed shift fork
- 30. Spring pin for 1st-2nd speed shift fork
- 31. Spring pin for OD-R shift fork
- 32. OD-R shift rail
- 33. 3rd-4th speed shift rail
- 34. OD-R shift fork
- 35. Interlock plunger
- 36. Countershaft lock nut
- 37. Countershaft rear bearing
- 38. Counter overdrive gear
- 39. 1st-2nd speed shift rail

V5M21-7-E

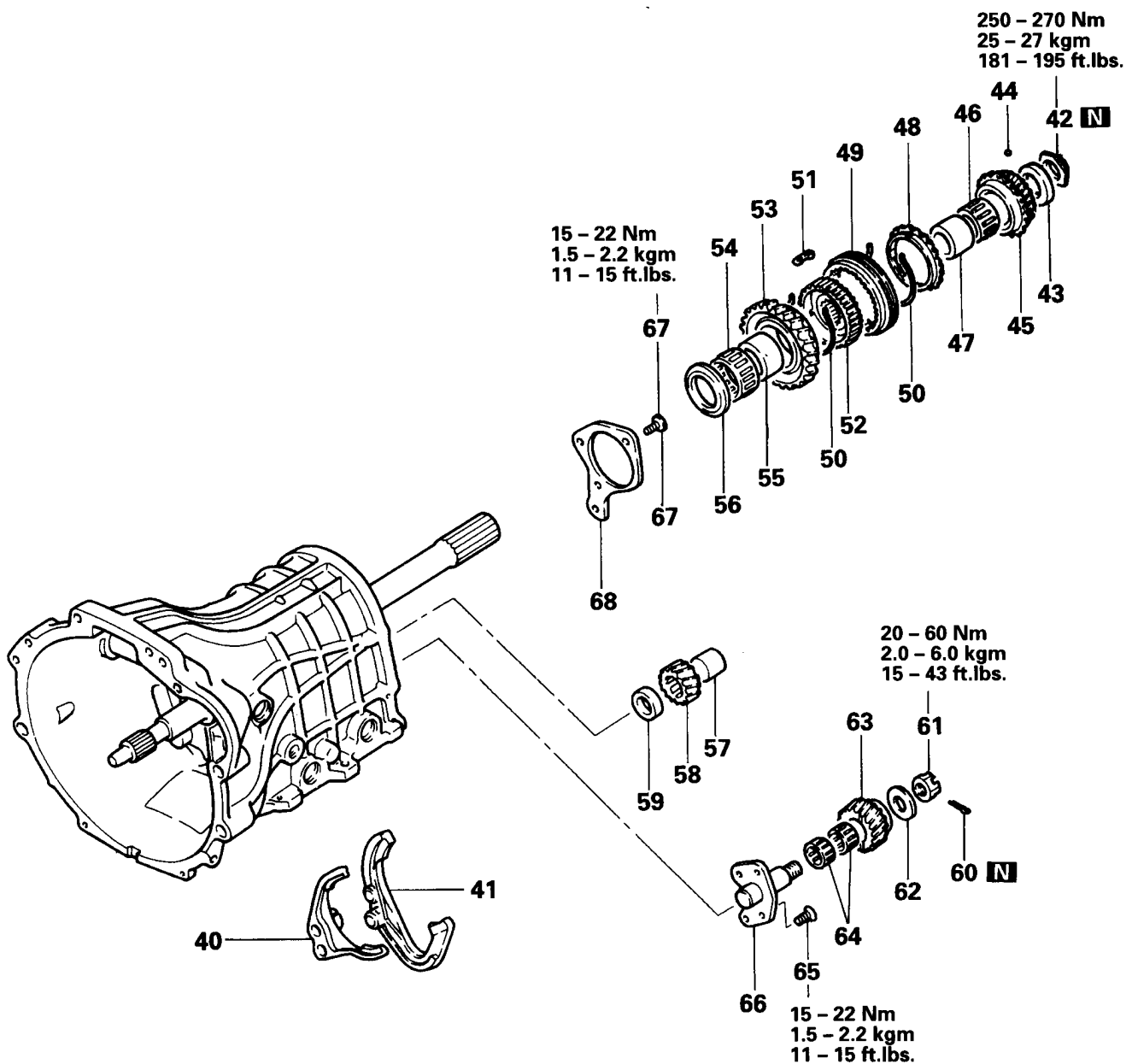

Disassembly steps

- 40. 3rd-4th speed shift fork
- 41. 1st-2nd speed shift fork
- ⓔ Ⓢ 42. Mainshaft lock nut
- 43. Spacer
- 44. Steel ball
- 45. Overdrive gear
- 46. Needle bearing
- ⓕ Ⓡ 47. Bearing sleeve
- Ⓠ 48. Overdrive synchronizer ring
- Ⓡ 49. OD-R synchronizer sleeve
- Ⓟ 50. OD-R synchronizer spring
- Ⓟ 51. OD-R synchronizer key
- Ⓡ 52. OD-R synchronizer hub
- 53. Reverse gear
- 54. Needle bearing
- Ⓝ 55. Reverse gear bearing sleeve
- 56. Spacer
- 57. Spacer
- 58. Counter reverse gear
- 59. Spacer
- 60. Split pin
- 61. Slotted nut
- 62. Thrust washer
- 63. Reverse idler gear
- 64. Needle bearing
- Ⓠ Ⓡ 65. Bolt
- ⓐ Ⓡ Ⓚ 66. Reverse idler gear shaft
- 67. Bolt
- 68. Rear bearing retainer

V5M21-7-E

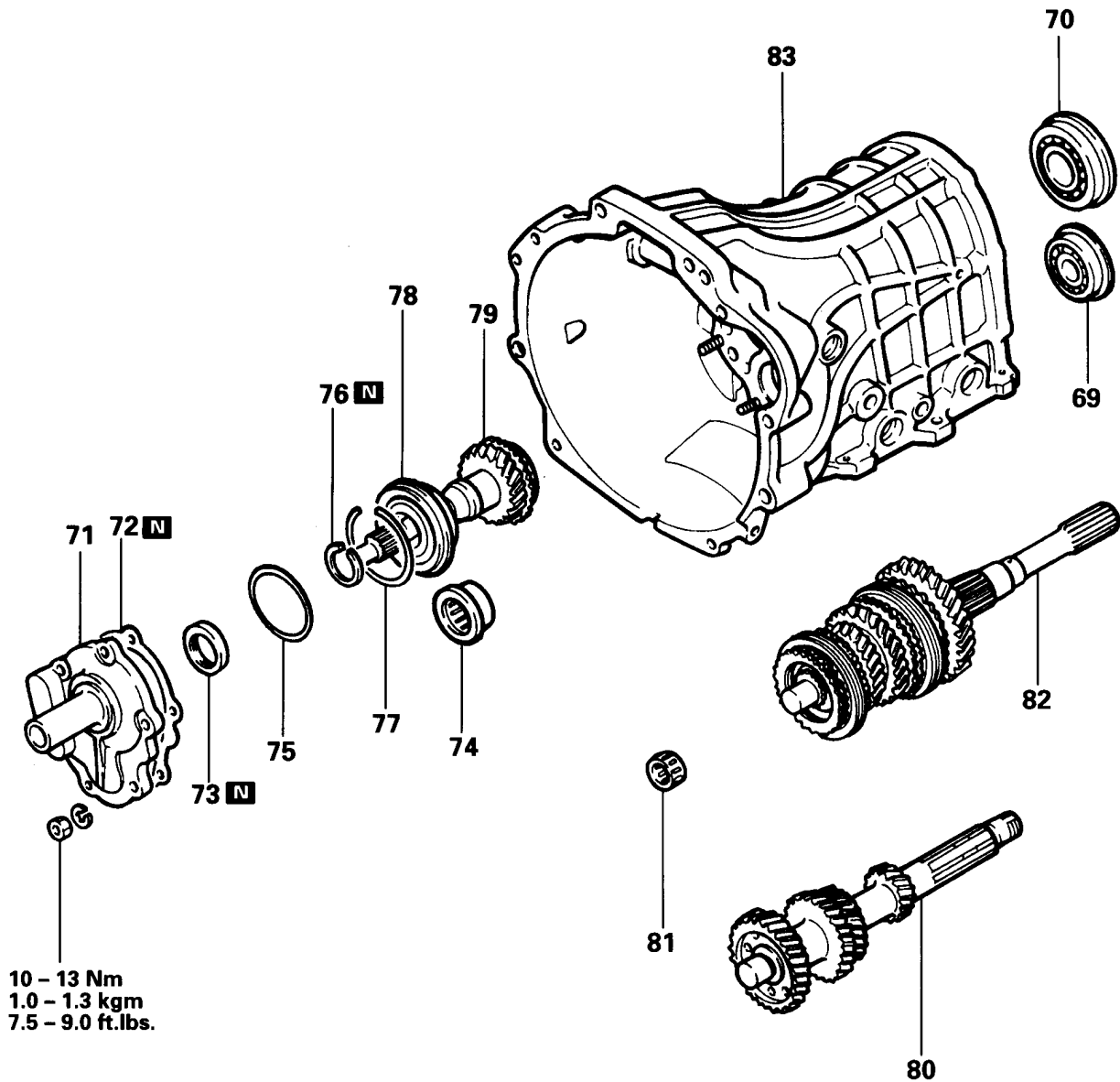

10 - 13 Nm
1.0 - 1.3 kgm
7.5 - 9.0 ft.lbs.

Disassembly steps

- (H) (I) 69. Countershaft center bearing
- (I) (H) 70. Mainshaft bearing
- (G) 71. Front bearing retainer
- (E) 72. Front bearing retainer gasket
- (J) (D) 73. Oil seal
- (F) 74. Countershaft front bearing
- (C) 75. Spacer
- (K) (B) 76. Snap ring
- (K) (B) 77. Snap ring
- (K) (B) 78. Maindrive gear bearing
- (K) (B) 79. Maindrive gear
- (K) (B) 80. Countershaft
- (K) (B) 81. Mainshaft front bearing
- (K) (B) 82. Mainshaft assembly
- (K) (B) 83. Transmission case

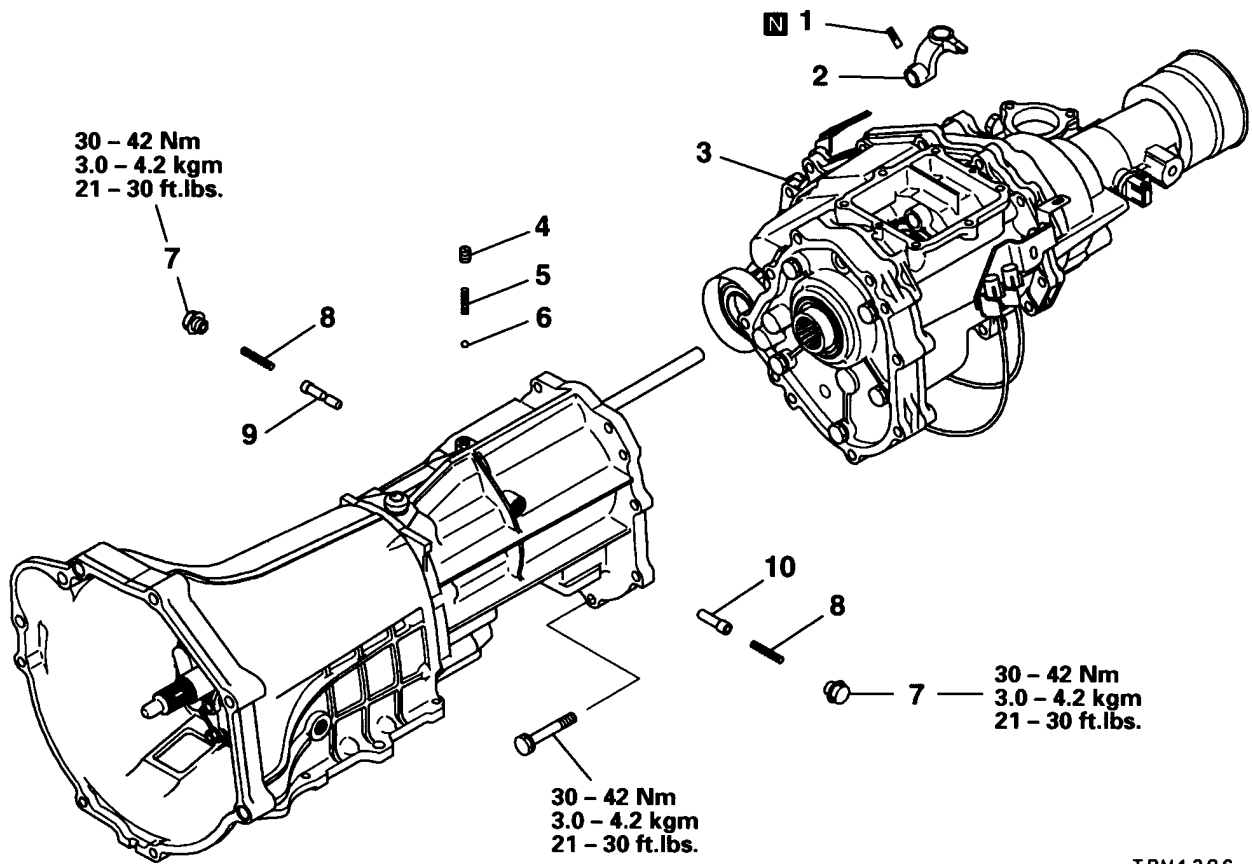

TRM1286

Disassembly steps

- Ⓐ I 1. Spring pin
- 2. Change shifter
- U S 3. Transfer assembly
- 4. Plug
- 5. Spring
- 6. Steel ball
- r 7. Seal plug
- 8. Neutral return spring
- q 9. Neutral return plunger B
- q 10. Neutral return plunger A

V5M21-A

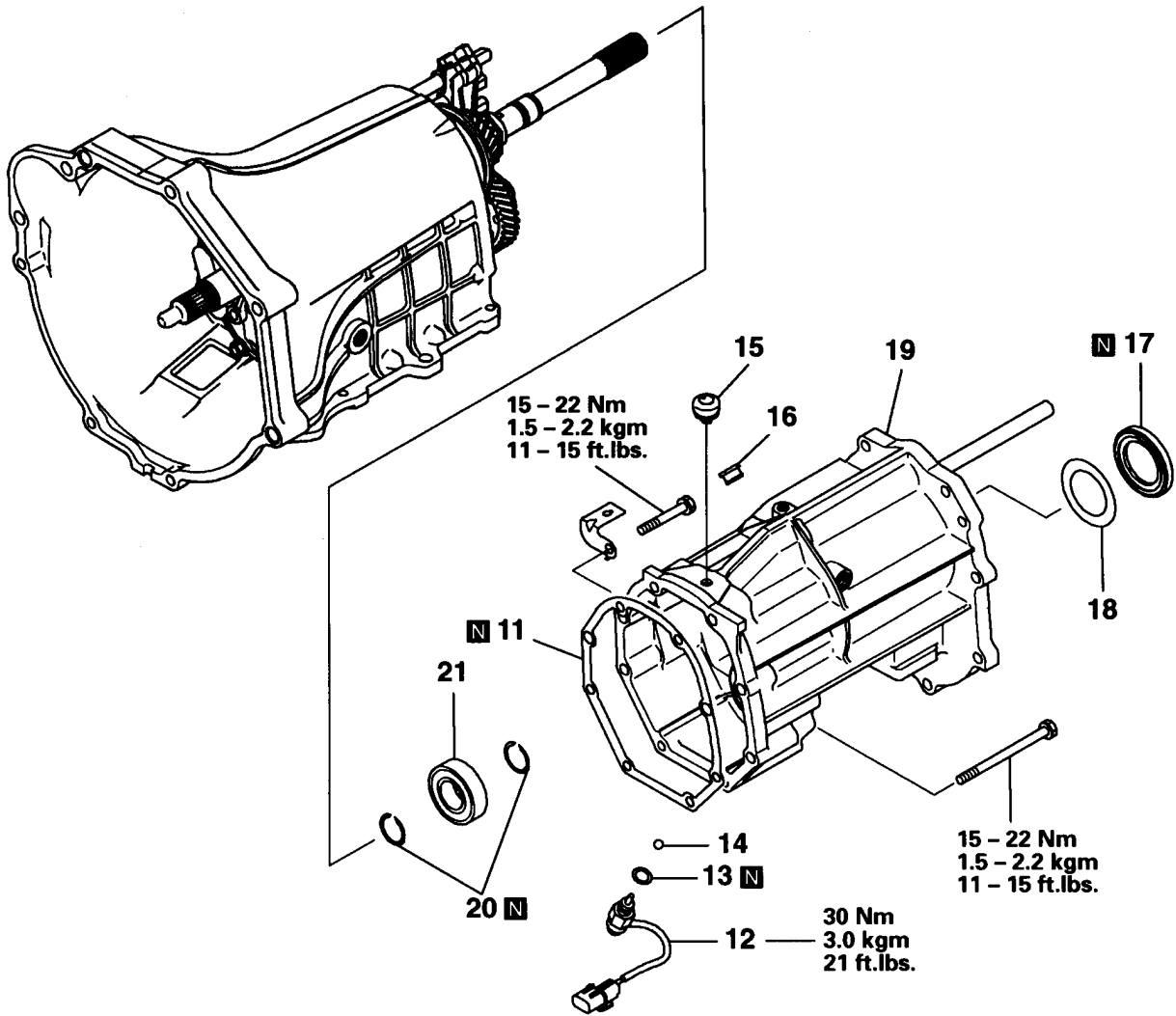

TRM1272

Disassembly steps

- [k]** 11. Transfer case adapter gasket
- 12. Back light switch
- 13. Gasket
- 14. Steel ball
- [j]** 15. Air breather
- 16. Plug
- [v]** 17. Oil seal
- 18. Baffle plate
- [B]** **[i]** 19. Transfer case adapter
- [p]** 20. Snap ring
- [p]** 21. Mainshaft rear bearing

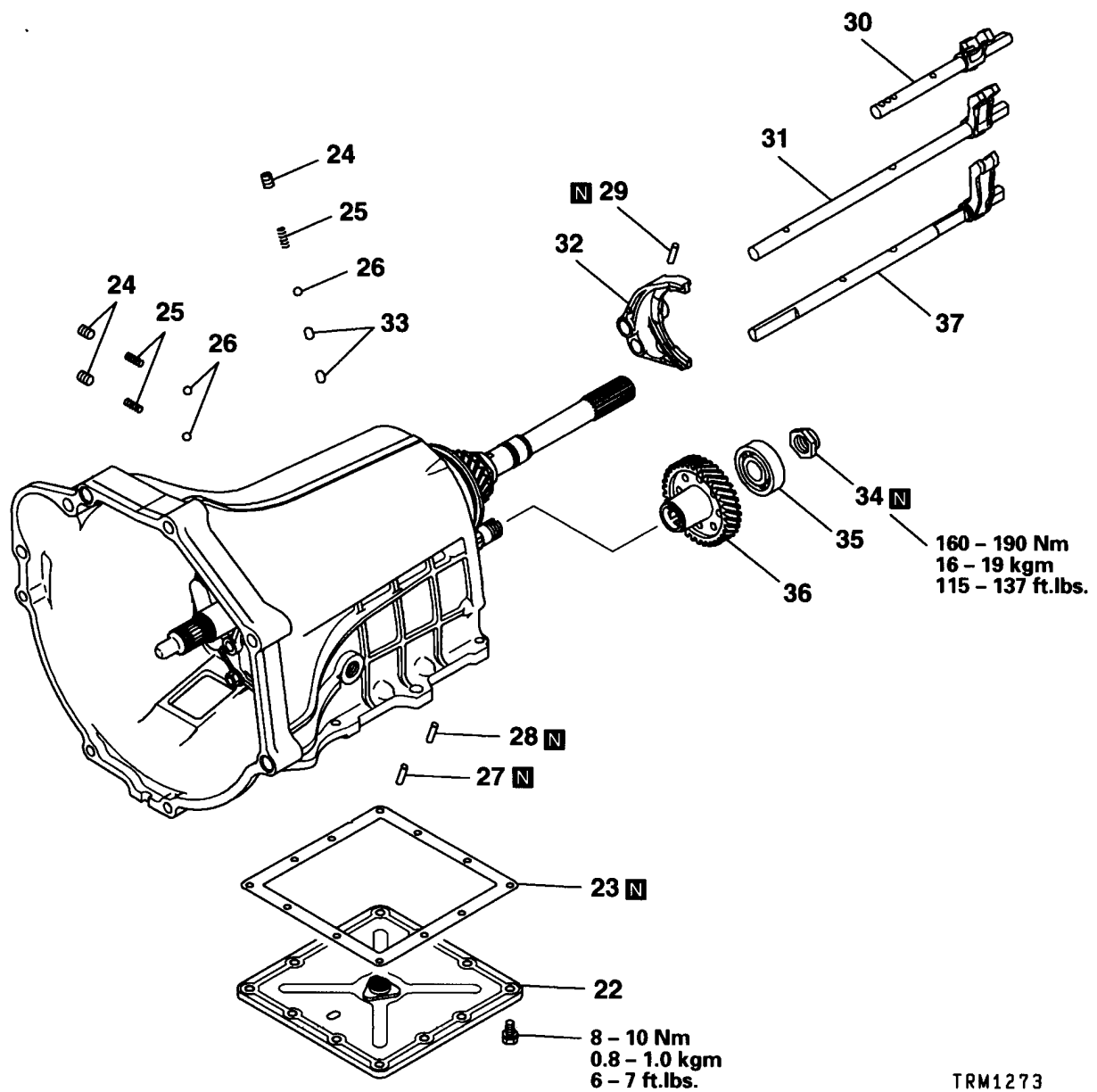

Disassembly steps

- | | |
|--|--|
| <ul style="list-style-type: none"> 22. Oil pan 23. Oil pan gasket b 24. Poppet plug b 25. Poppet spring 26. Steel ball Y 27. Spring pin for 3rd-4th speed shift fork Y 28. Spring pin for 1st-2nd speed shift fork X 29. Spring pin for OD-R shift fork | <ul style="list-style-type: none"> 30. OD-R shift rail 31. 3rd-4th speed shift rail 32. OD-R shift fork 33. Interlock plunger V 34. Countershaft lock nut U 35. Countershaft rear bearing 36. Countershaft overdrive gear 37. 1st-2nd speed shift rail |
|--|--|

TRM1273

V5M21-A

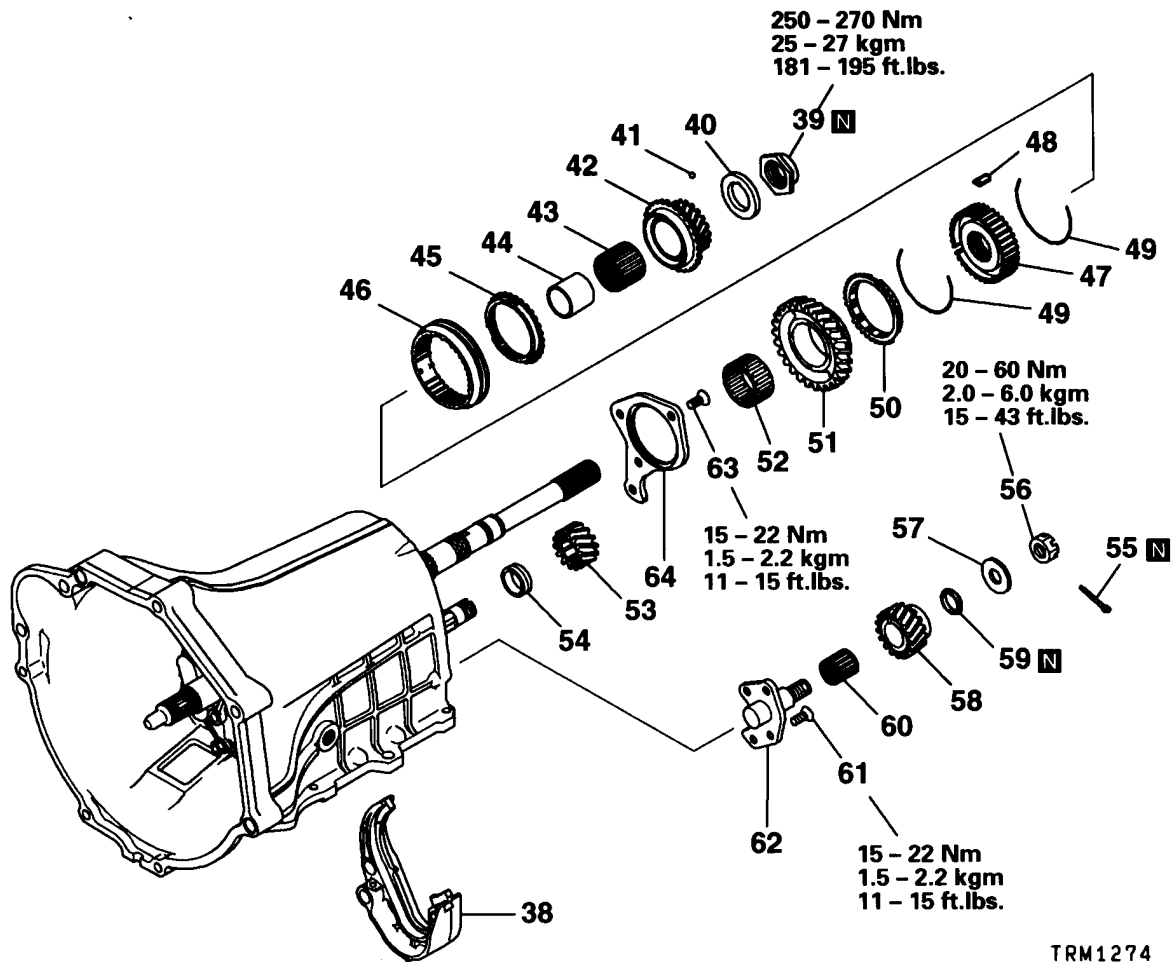

TRM1274

Disassembly steps

- 38. 1st-2nd speed shift fork
- ⓔ Ⓢ 39. Mainshaft lock nut
- 40. Spacer
- 41. Steel ball
- 42. Overdrive gear
- 43. Needle bearing
- ⓕ Ⓡ 44. Bearing sleeve
- ⓕ Ⓠ 45. Overdrive synchronizer ring
- ⓕ Ⓡ 46. OD-R synchronizer sleeve
- ⓕ Ⓡ 47. OD-R synchronizer hub
- ⓕ Ⓡ 48. OD-R synchronizer key
- ⓕ Ⓡ 49. OD-R synchronizer spring
- ⓕ Ⓡ 50. Reverse synchronizer ring
- 51. Reverse gear
- 52. Needle bearing
- 53. Counter reverse gear
- 54. Spacer
- 55. Split pin
- 56. Reverse idler gear shaft nut
- 57. Thrust washer
- 58. Reverse idler gear
- Ⓣ 59. Friction damper
- 60. Needle bearing
- Ⓜ 61. Reverse idler gear shaft seal bolt
- Ⓦ 62. Reverse idler gear shaft
- Ⓚ 63. Rear bearing retainer seal bolt
- 64. Rear bearing retainer

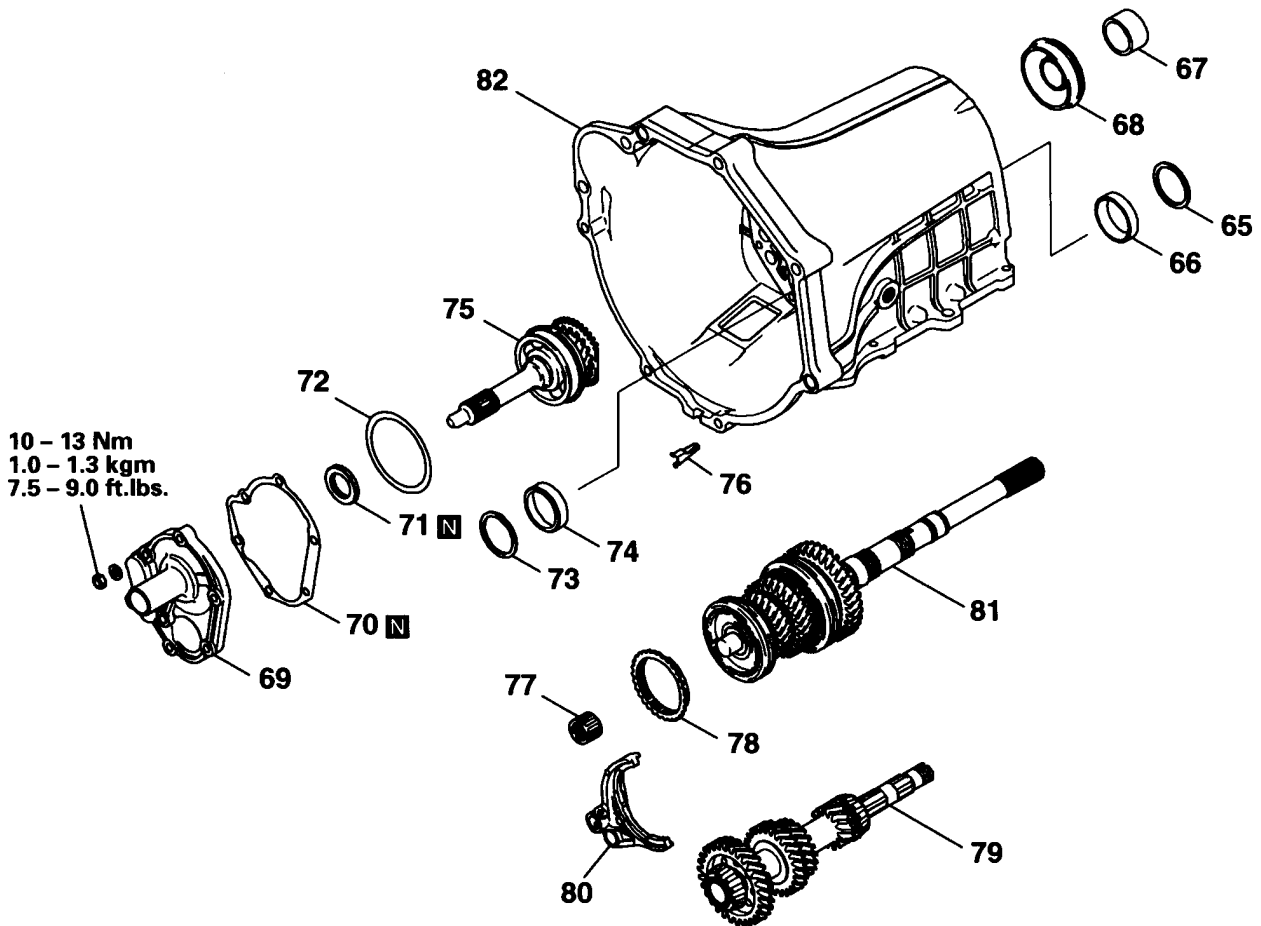

TRM1275

Disassembly steps

- | | |
|--|---|
| <ul style="list-style-type: none"> J 65. Spacer 66. Countershaft center bearing outer race N 67. Reverse gear bearing sleeve 68. Mainshaft center bearing outer race 69. Front bearing retainer G 70. Front bearing retainer gasket E 71. Oil seal F 72. Spacer 73. Spacer | <ul style="list-style-type: none"> L A 74. Countershaft front bearing outer race 75. Main drive gear 76. Oil guide 77. Mainshaft front bearing 78. Synchronizer ring 79. Countershaft 80. 3rd-4th speed shift fork 81. Mainshaft 82. Transmission case |
|--|---|

Intentionally blank

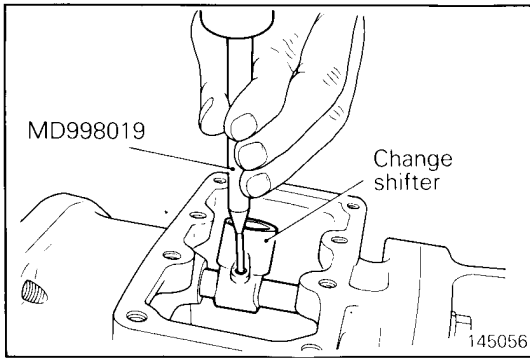

SERVICE POINTS OF DISASSEMBLY

Ⓐ REMOVAL OF SPRING PIN

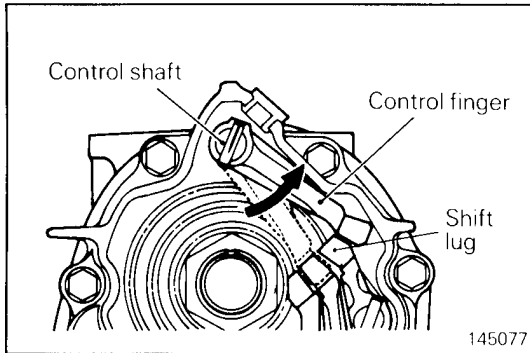

Ⓑ REMOVAL OF EXTENTION HOUSING OR TRANSFER ADAPTER

- (1) Turn the control shaft to the counterclockwise and remove the control finger from the groove in the shift lug, then remove the extention housing or the transfer adapter from the transmission case.

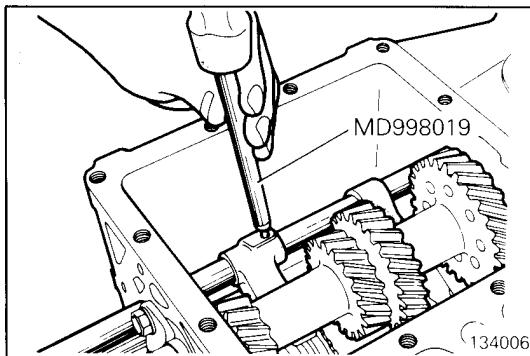

Ⓒ REMOVAL OF SPRING PIN

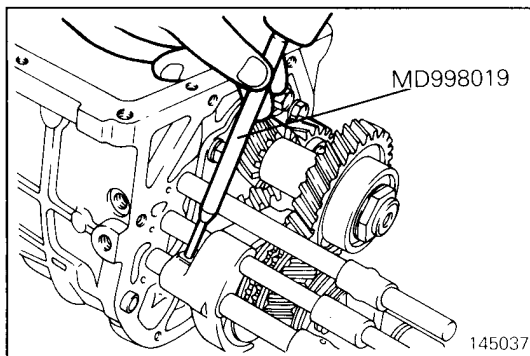

Ⓓ REMOVAL OF SPRING PIN

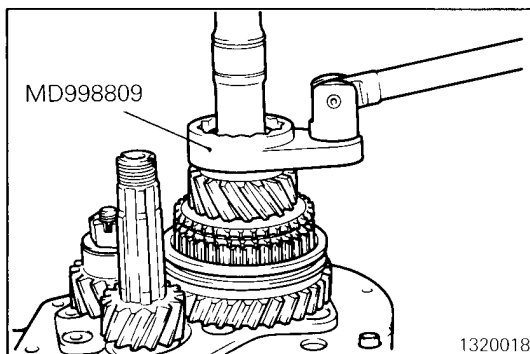

Ⓔ REMOVAL OF MAINSHAFT LOCK NUT

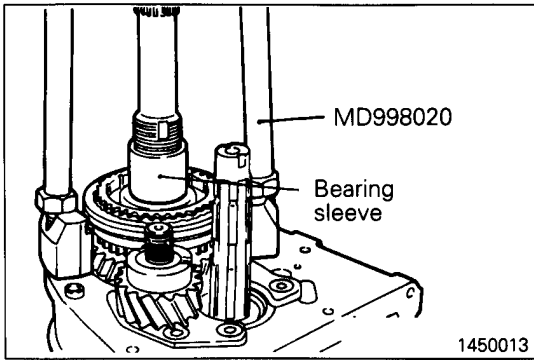

Ⓕ REMOVAL OF OVERDRIVE GEAR BEARING SLEEVE

NOTE

- (1) For KM135, KM145, KM147, R5M21-2, 3, 8 and V5M21, use MD998020.
- (2) For KM132 and R5M21-4, 7, use MD998020 together with MD998028.

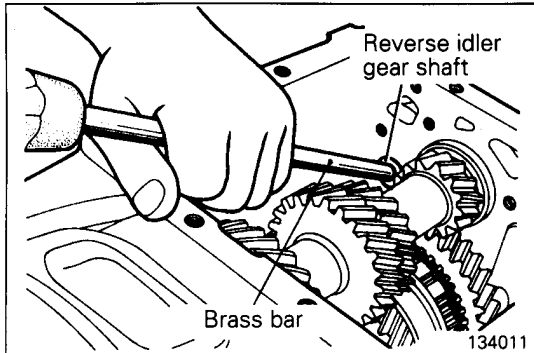

Ⓖ REMOVAL OF REVERSE IDLER GEAR SHAFT

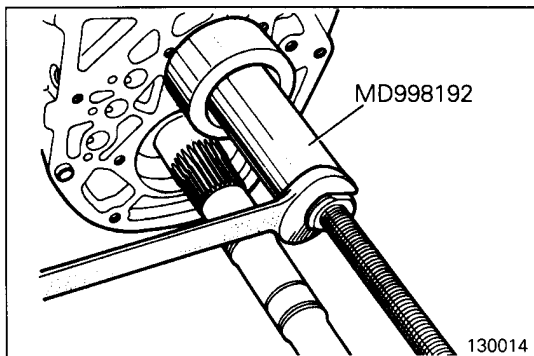

Ⓗ REMOVAL OF COUNTERSHAFT CENTER BEARING

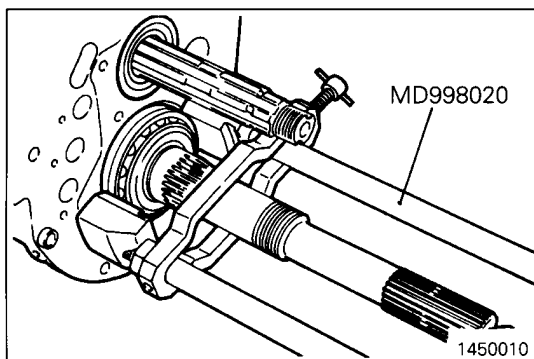

Ⓘ REMOVAL OF MAINSHAFT REAR BEARING

NOTE

- (1) For KM131, KM135, KM145, KM147, R4M21-2, R5M21-2, 3, 8 and V5M21, use MD998020.
- (2) For KM130, KM132, R4M21-1 and R5M21-4, 7, use MD998020 together with MD998028.

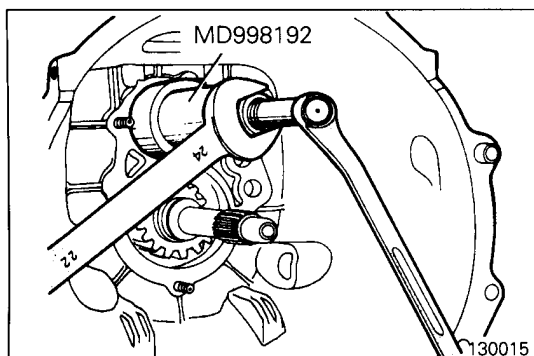

Ⓙ REMOVAL OF COUNTERSHAFT FRONT BEARING

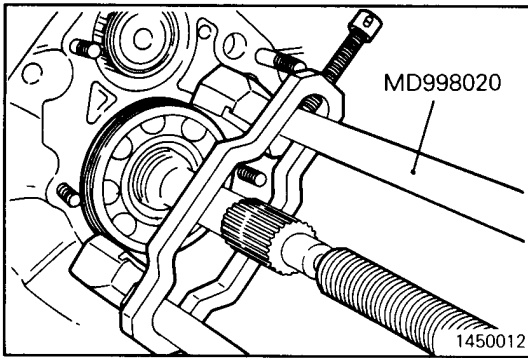

Ⓚ REMOVAL OF MAINDRIVE GEAR BEARING

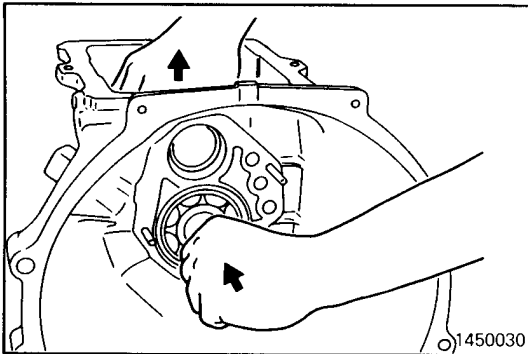

Ⓛ REMOVAL OF MAINDRIVE GEAR ASSEMBLY

- (1) Pushing on the maindrive gear assembly, remove the countershaft assembly and remove the maindrive gear assembly.

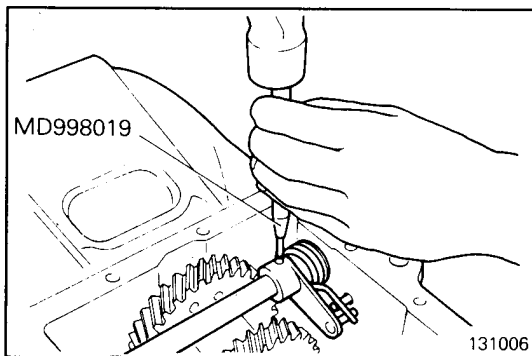

Ⓜ REMOVAL OF SPRING PIN FOR ADJUST ARM

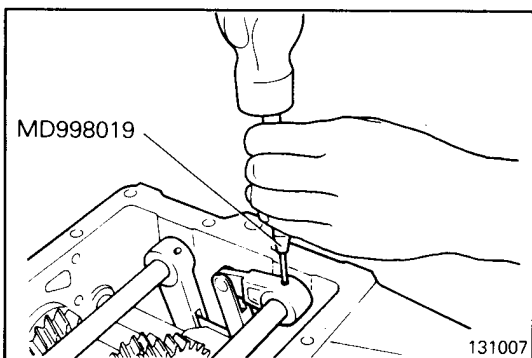

Ⓝ REMOVAL OF SPRING PIN FOR CONTROL LINK

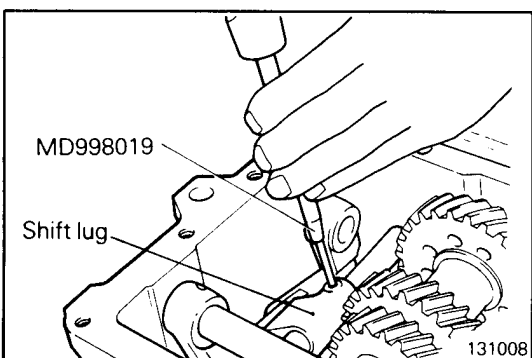

Ⓞ REMOVAL OF SPRING PIN FOR SHIFT LUG

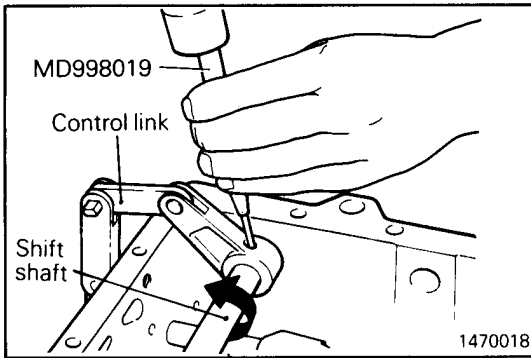

Ⓟ REMOVAL OF LOCK PIN FOR CONTROL LINK

- (1) Slide the OD-R shift lug either side.
- (2) Lift control link out of groove in shift lug, and turn the shift shaft half a turn.
- (3) Using the special tool, drive out the lock pin from control link and shaft.

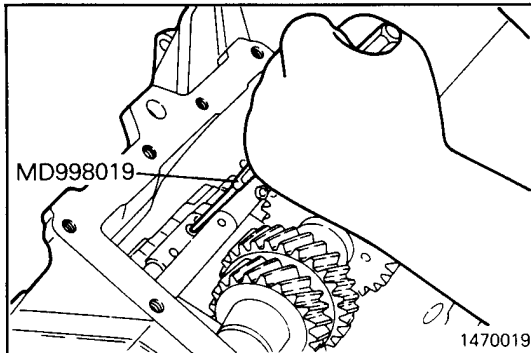

Ⓞ REMOVAL OF SPRING PINS FOR 1ST-2ND SPEED SHIFT LUG / 3RD-4TH SPEED SHIFT LUG

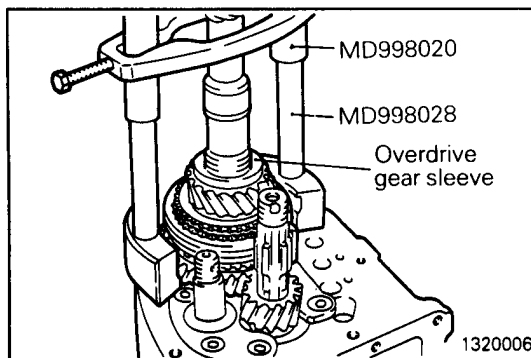

Ⓡ REMOVAL OF OVERDRIVE GEAR SLEEVE / NEEDLE BEARING / OVERDRIVE GEAR

SERVICE POINTS OF REASSEMBLY

ⓐ INSTALLATION OF COUNTERSHAFT ASSEMBLY

- (1) Pushing on the maindrive gear assembly, install the countershaft assembly.

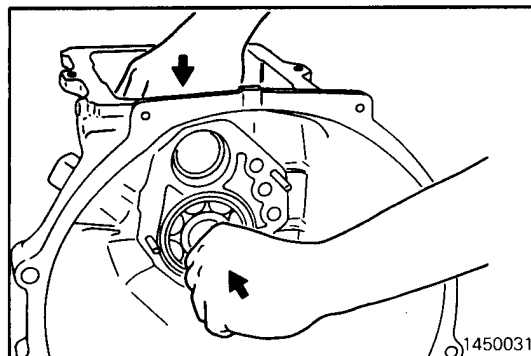

ⓑ INSTALLATION OF MAIN DRIVE GEAR BEARING

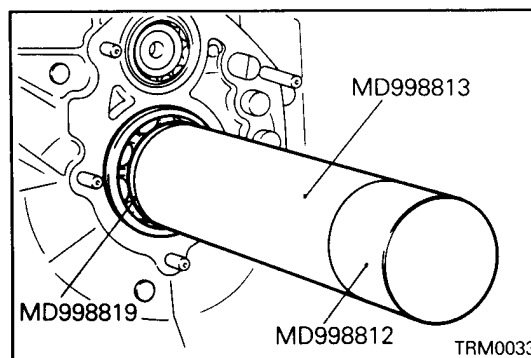

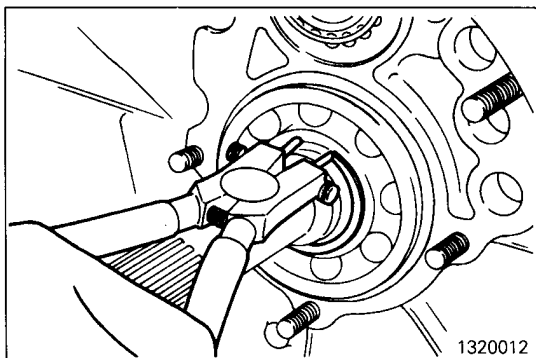

C INSTALLATION OF SNAP RING

- (1) Select and install snap ring so that main drive gear bearing end play reaches the standard value.

Standard value:
0 – 0.06 mm (0 – 0.0024 in.)

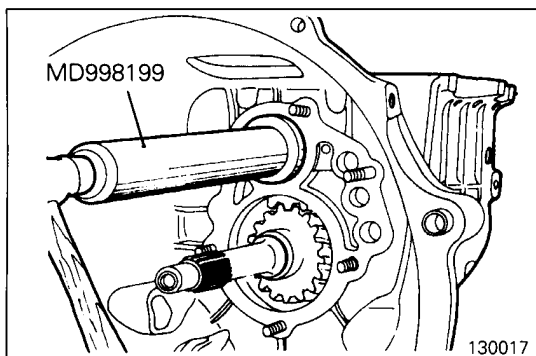

D INSTALLATION OF COUNTERSHAFT FRONT BEARING

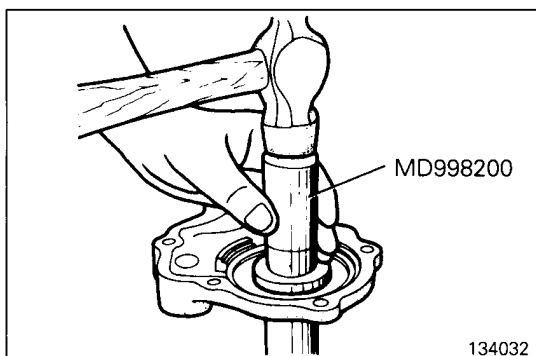

E INSTALLATION OF OIL SEAL

- (1) After applying transmission oil to the oil seal lips, use a special tool to install the oil seal.

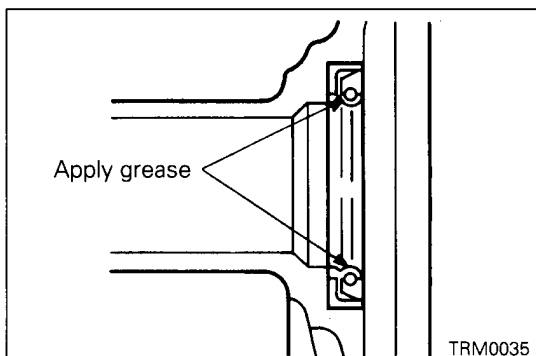

- (2) The only exception is the seal on the maindrive gear bearing. In this case, apply grease to the oil seal lips.

Specified grease:
Mitsubishi genuine grease Part No. 0101011 or equivalent

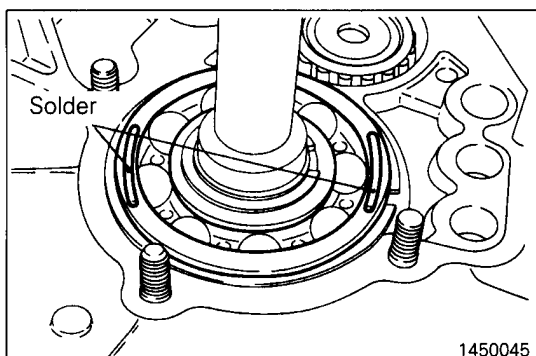

F INSTALLATION OF SPACER

- (1) Place two pieces of solder measuring about 10 mm (0.39 in.) in length and 1.6 mm (0.063 in.) in diameter on the bearing outer race as shown in the illustration.
- (2) Install the front bearing retainer and tighten the nuts to the specified torque.
- (3) Remove the front bearing retainer and remove the solder.

NOTE
 If the solder wire 1.6 mm (0.063 in.) diameter have not crushed, use the one with 3 mm (0.12 in.) diameter.

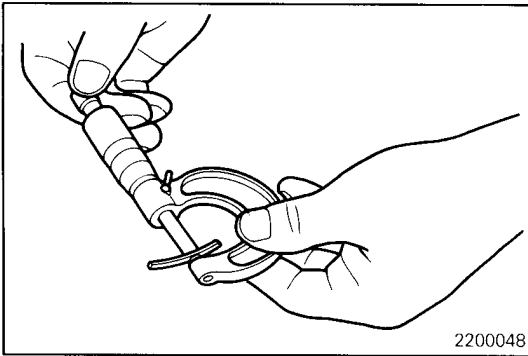

- (4) Measure the thickness of the crushed solder with a micrometer and select and install a spacer of thickness that gives standard end play.

Standard value:

0 – 0.1 mm (0 – 0.004 in.)

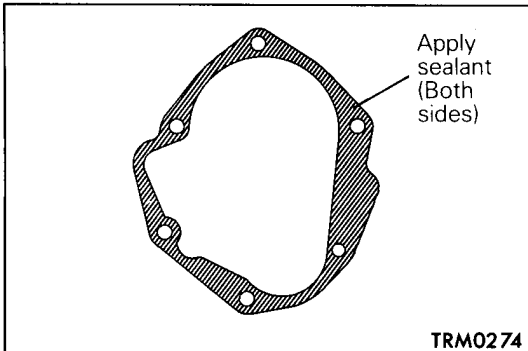

G APPLICATION OF SEALANT TO FRONT BEARING RETAINER GASKET

Specified sealant:

Mitsubishi genuine sealant Part No. 997740 or equivalent

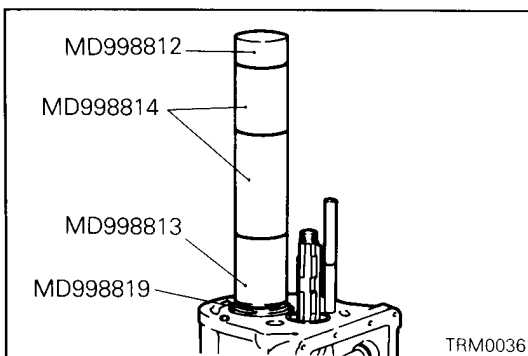

H INSTALLATION OF MAINSHAFT CENTER BEARING

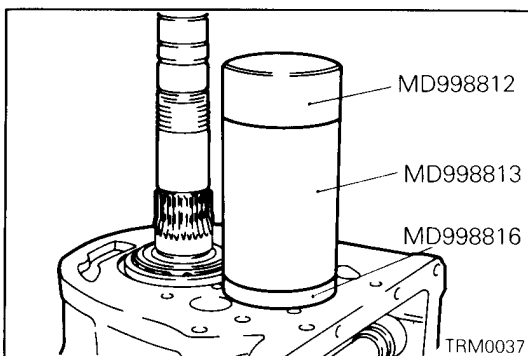

I INSTALLATION OF COUNTERSHAFT CENTER BEARING

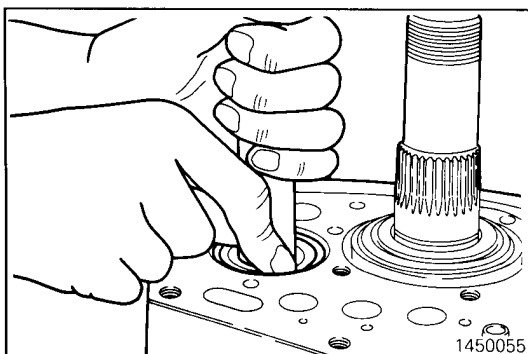

J INSTALLATION OF SPACER

- (1) Press the outer race and counter gear in positively.

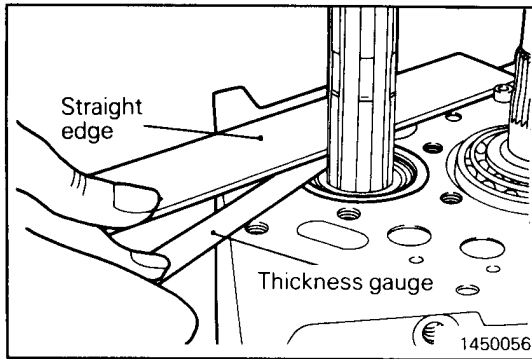

- (2) Install the selective spacer and use a straight edge.
- (3) Select an appropriate, spacer to obtain the standard value.
Standard value: 0 – 0.05 mm (0 – 0.0020 in.)

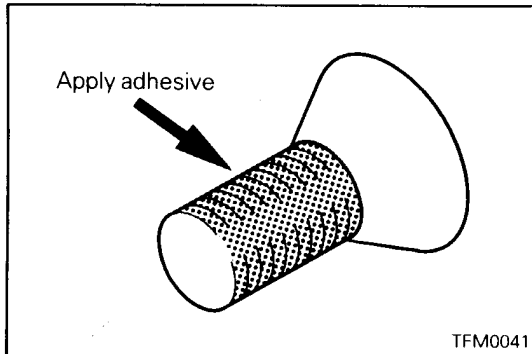

K APPLICATION OF ADHESIVE TO REAR BEARING RETAINER BOLT

Specified adhesive:
3M STUD Locking No. 4170 or equivalent

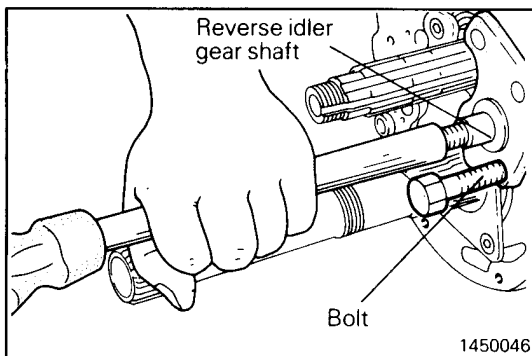

L INSTALLATION OF REVERSE IDLER GEAR SHAFT

- (1) Use the bolt (M8 x 50 mm) as a guide to install the reverse idler gear shaft.

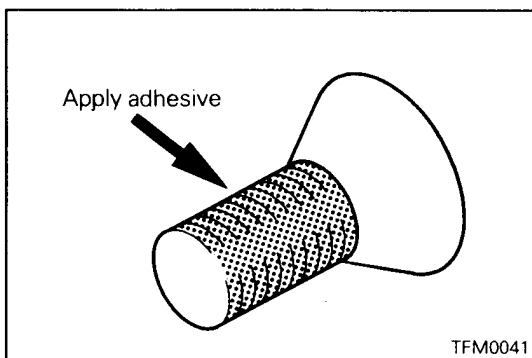

M APPLICATION OF ADHESIVE TO REVERSE IDLER GEAR SHAFT BOLT

Specified adhesive:
3M STUD Locking No. 4170 or equivalent

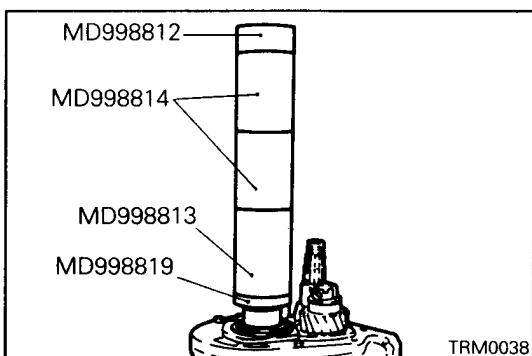

N INSTALLATION OF REVERSE GEAR BEARING SLEEVE

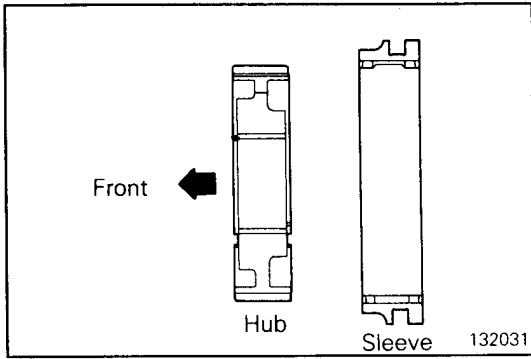

Q INSTALLATION OF SYNCHRONIZER HUB / OD-R SYNCHRONIZER SLEEVE

- (1) Assemble the synchronizer hub and sleeve. Make sure that hub and sleeve slide smoothly.
- (2) Insert three keys into grooves of hub. Assemble the keys as shown in illustration since it has a definite direction to be assembled.

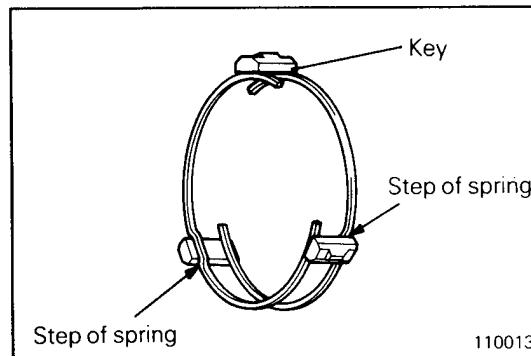
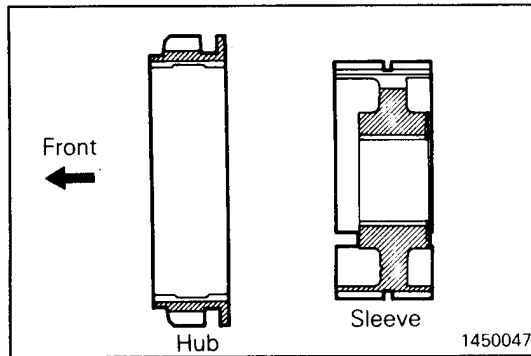

P INSTALLATION OF SYNCHRONIZER KEY / SYNCHRONIZER SPRING

- (1) When installing springs, make sure that steps of front and rear springs are positioned on synchronizer key, but not on the same key.

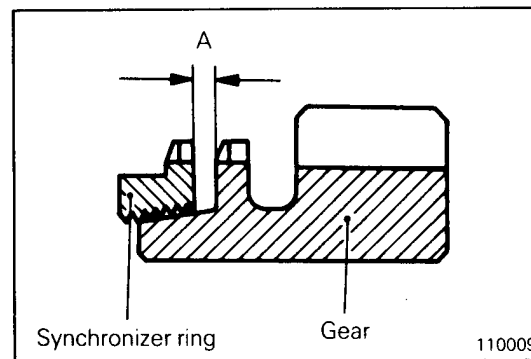

Q INSTALLATION OF SYNCHRONIZER RING

- (1) Engage the synchronizer ring to OD gear as shown in illustration before installing OD gear and ensure that there is certain clearance "A". If dimension "A" exceeds the limit, replace the ring and/or gear.

Limit: 0.5 mm (0.020 in.)

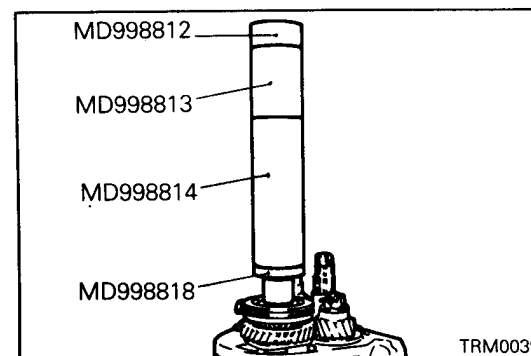

R INSTALLATION OF GEAR BEARING SLEEVE

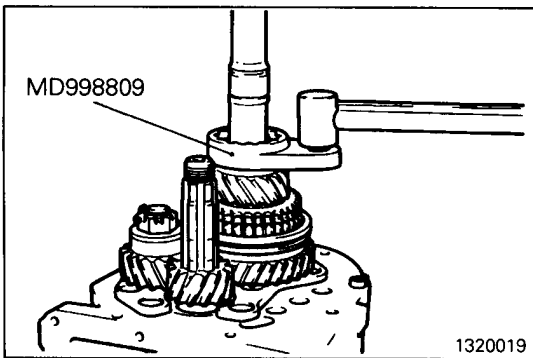

S INSTALLATION OF MAIN SHAFT LOCK NUT

(1) Using the special tool, tighten the main shaft lock nut.

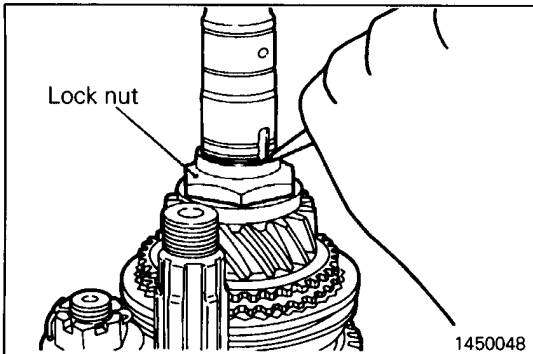

(2) Stake the lock nut as shown in the illustration.
 (3) Ensure that the OD gear rotates smoothly.

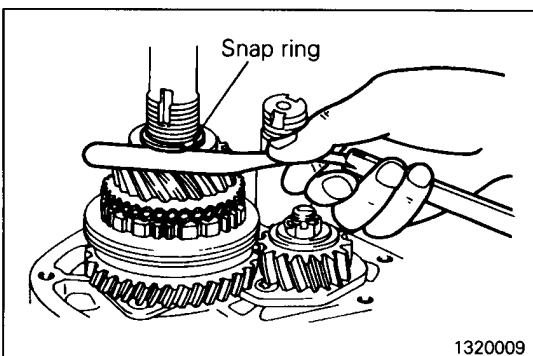

T INSTALLATION OF SNAP RING

(1) Before installing the snap ring, tighten the lock nut to the specified torque.
 (2) Remove the lock nut.
 (3) Measure the end play. Select a snap ring of a thickness appropriate for the specified end play and install it in position.

Standard value 0 – 0.2 mm (0 – 0.008 in.)

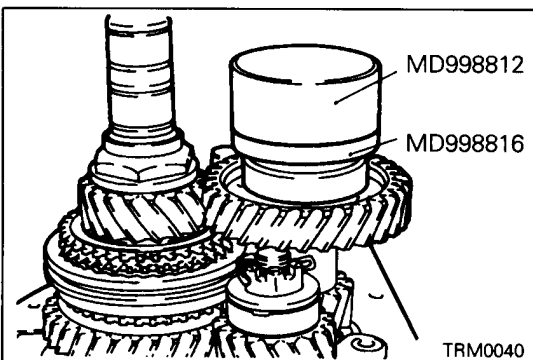

U INSTALLATION OF COUNTER REAR BEARING

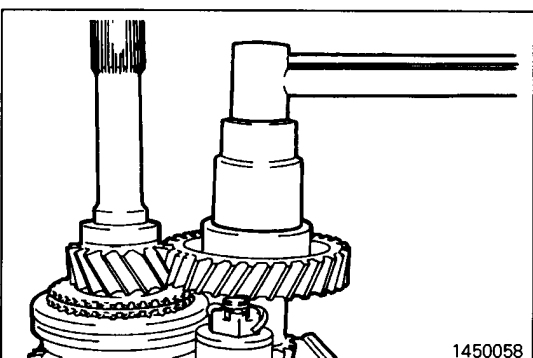

V INSTALLATION OF COUNTERSHAFT LOCK NUT

(1) Tighten the countershaft lock nut to the specified torque.

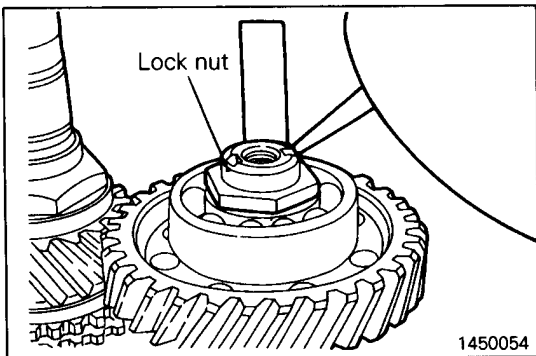

- (2) Stake the area as shown in illustration without fail to prevent lock nut from tightening.
- (3) Ensure that the OD gear rotates smoothly.

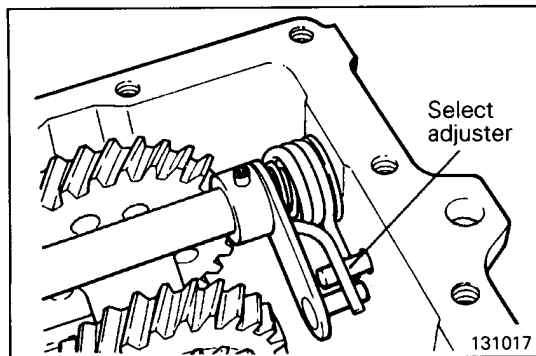

W INSTALLATION OF SELECT ADJUSTER

- (1) Install the select adjuster in such a way that its end will be positioned between the ends of the return spring.

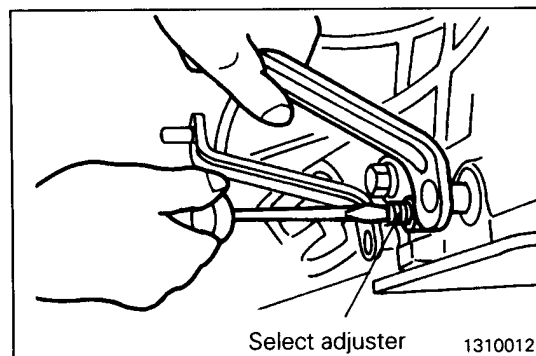

- (2) Thread the select adjuster all the way in.
- (3) Loosen the select adjuster to the extent that the shift shaft, when operated, can shift smoothly.
- (4) Lock the select adjuster with the lock nut.

NOTE

When adjusting the select adjuster, make sure not to back it off more than two turns.

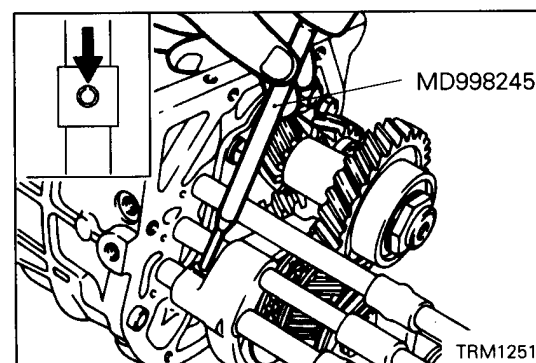

X INSTALLATION OF SPRING PIN

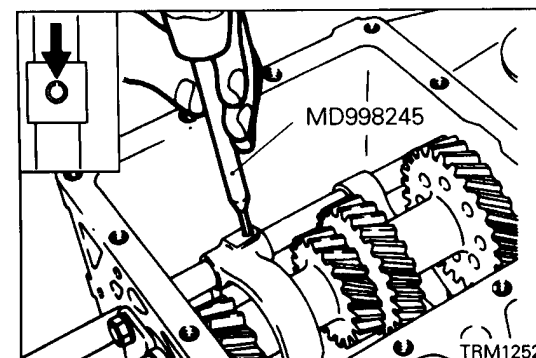

Y INSTALLATION OF SPRING PINS FOR 3RD-4TH SPEED SHIFT FORK / 1ST-2ND SPEED SHIFT FORK

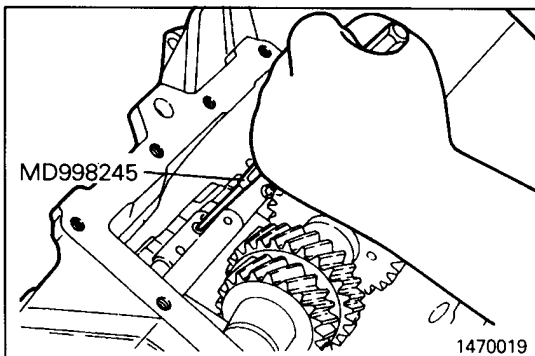

Z INSTALLATION OF SPRING PINS FOR 3RD-4TH SPEED SHIFT LUG / 1ST-2ND SPEED SHIFT LUG

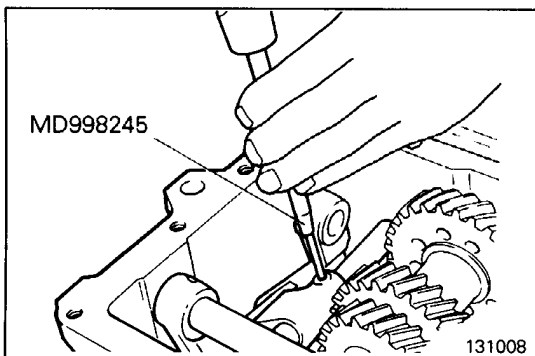

a INSTALLATION OF SPRING PIN

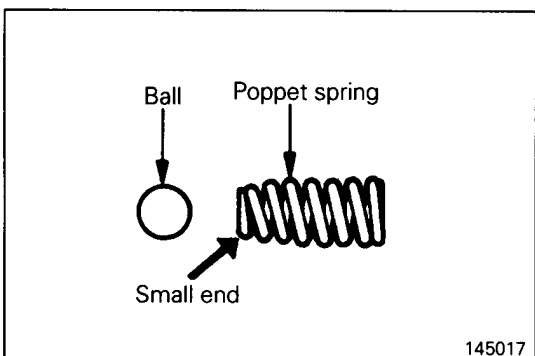

b INSTALLATION OF STEEL BALL / POPPET SPRING

(1) Insert the poppet spring with small end on ball side. Three springs are identical to one another.

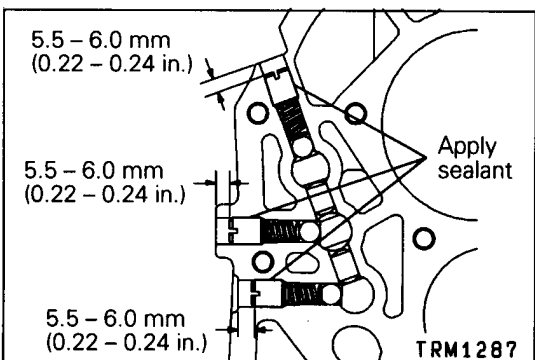

(2) Apply sealant to the poppet plug.

Specified sealant:
3M ATD Part No. 8660 or equivalent

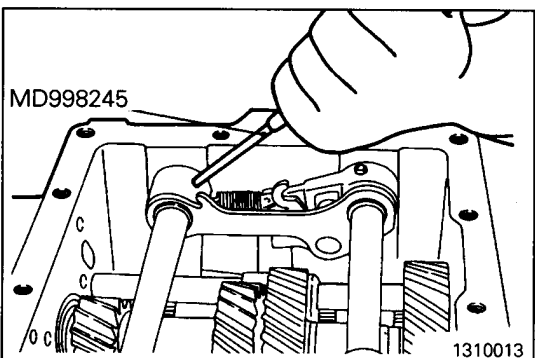

c INSTALLATION OF LOCK PIN FOR CONTROL LINK

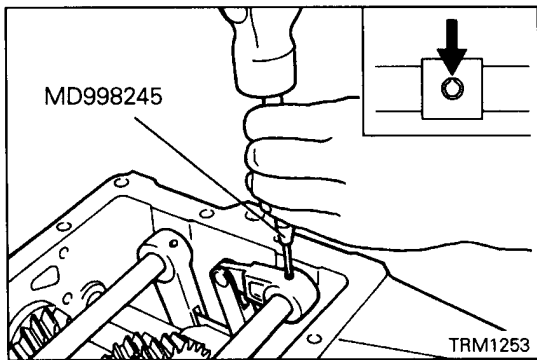

d INSTALLATION OF SPRING PIN FOR CONTROL LINK

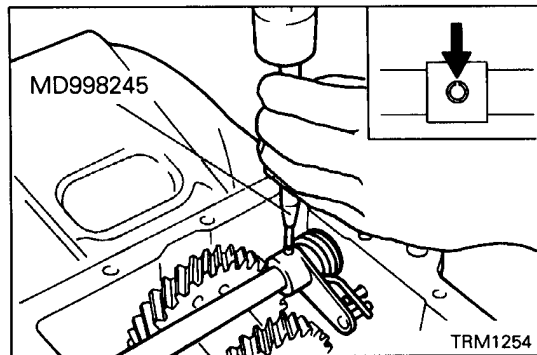

e INSTALLATION OF SPRING PIN FOR ADJUST ARM

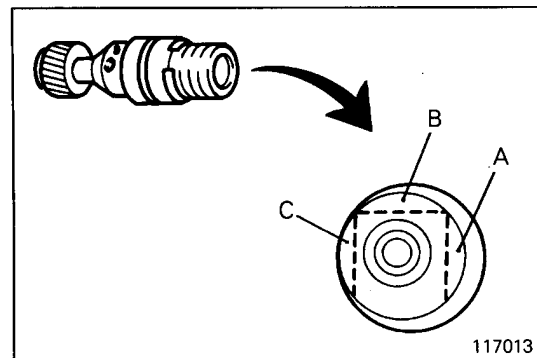

f INSTALLATION OF SPEEDOMETER GEAR

(1) Install the speedometer gear with its white paint coated portion (grooves) for identification directed toward the locking plate.

No. of driven gear teeth:

15 – 17	groove in area B
18 – 20	groove in area A
21 – 30	groove in area C

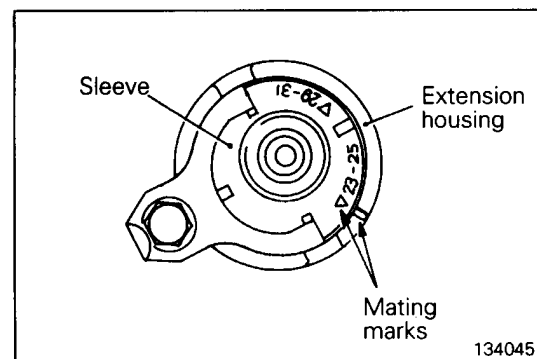

g INSTALLATION OF SPEEDOMETER GEAR

(1) Match the mating marks to the number of teeth.

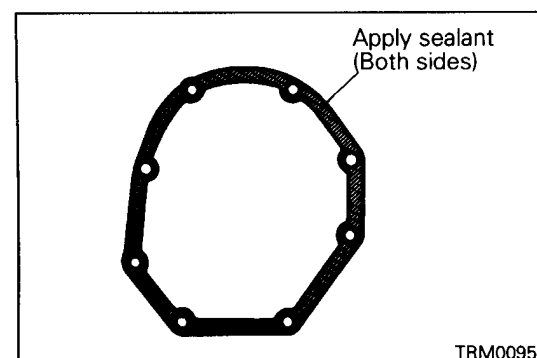

h APPLICATION OF SEALANT TO GASKET FOR CASE GASKET

Specified sealant:

Mitsubishi genuine sealant Part No. 997740 or equivalent

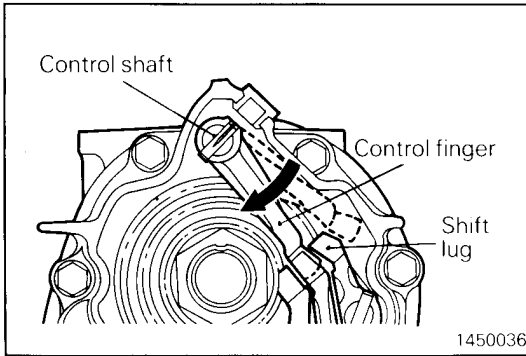

i INSTALLATION OF TRANSFER ADAPTER OR EXTENSION HOUSING

- (1) Turn the control shaft to the counterclockwise and install the transfer adapter.
- (2) Turn the control shaft to the clockwise and insert the control finger in the groove of the shift lug.

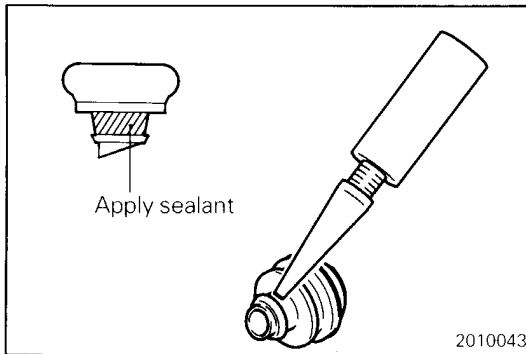

j APPLICATION OF SEALANT TO AIR BREATHER

- (1) Apply specified sealant to air breather.

Specified sealant:

3M Super Weatherstrip No. 8001 or equivalent

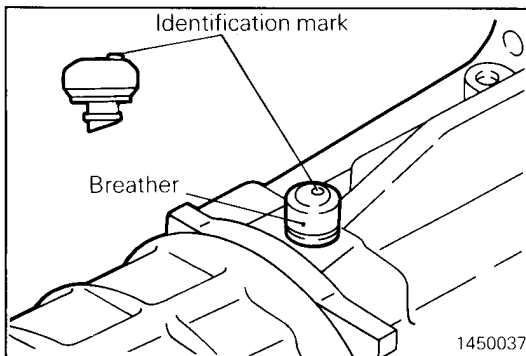

- (2) Install the breather with the identification mark toward the rear.

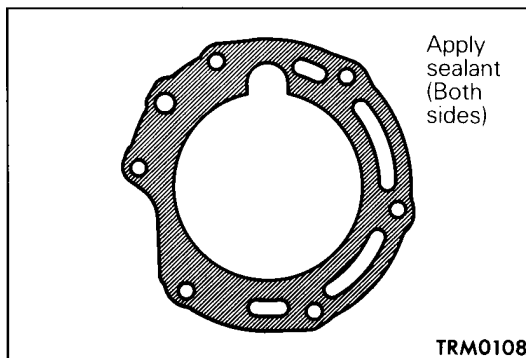

k APPLICATION OF SEALANT TO ADAPTER GASKET

Specified sealant:

Mitsubishi genuine sealant Part No. 997740 or equivalent

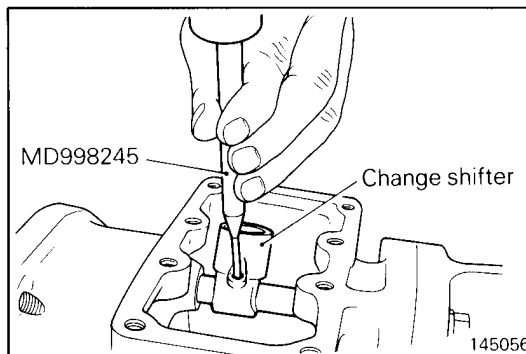

l INSTALLATION OF SPRING PIN FOR CHANGE SHIFTER

Caution

- Do not reuse spring pin.

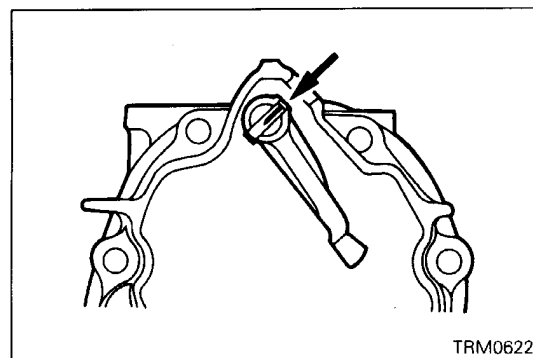
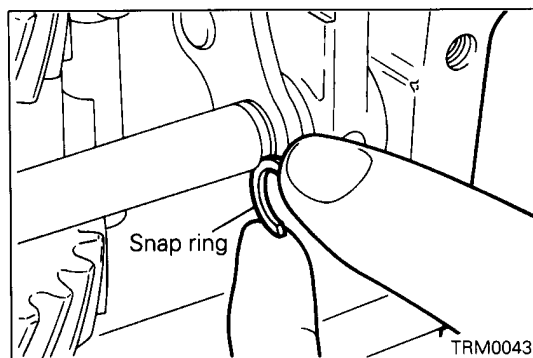
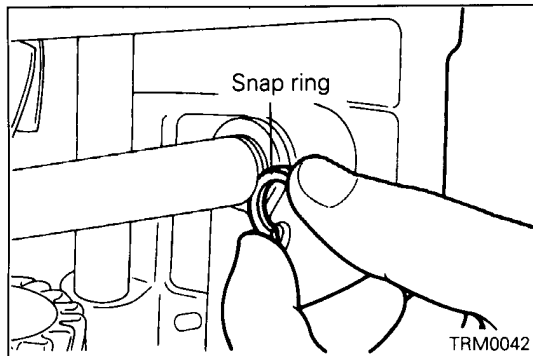
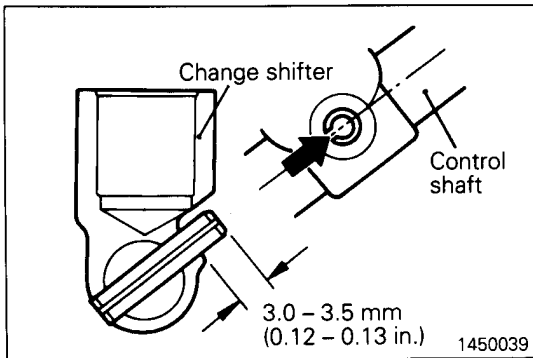

m INSTALLATION OF SNAP RING

- (1) Select and install the snap ring so that the shift shaft end play reaches the standard value.

Standard value:

Control rink side:

0.1 – 0.4 mm (0.004 – 0.016 in.)

Spacer side:

0.1 – 0.45 mm (0.004 – 0.0177 in.)

n INSTALLATION OF SNAP RING

- (1) Select and install the snap ring so that the select shaft end play reaches the standard value.

Standard value:

0.1 – 0.4 mm (0.004 – 0.016 in.)

o INSTALLATION OF LOCK PIN

- (1) Strike the lock pin into the control shaft through the hole of the transfer adapter as shown in the illustration.

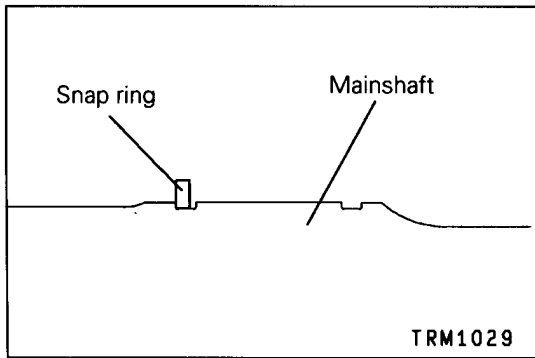

p **INSTALLATION OF MAINSHAFT REAR BEARING SNAP RING**

(1) Install a snap ring of the same size as having been used.

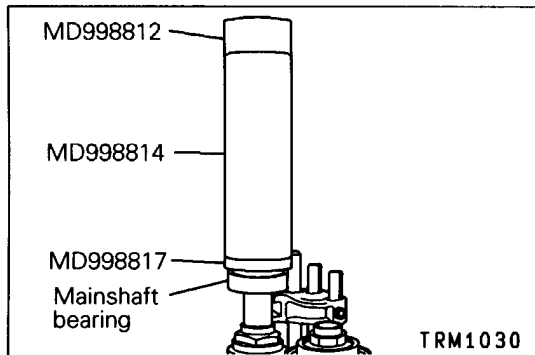

(2) Use the special tools to install the mainshaft rear bearing.

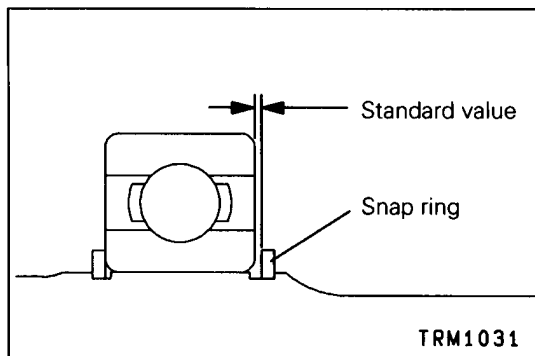

(3) Select and install a snap ring with which the mainshaft rear bearing clearance can be adjusted to the standard value.

Standard value: 0 – 0.13 mm (0 – 0.0051 in.)

(4) If neither of snap rings can adjusted the mainshaft rear bearing clearance to the standard value, repeat the steps (2) and (3) after replacing the snap ring installed in step (1) with one having a different size.

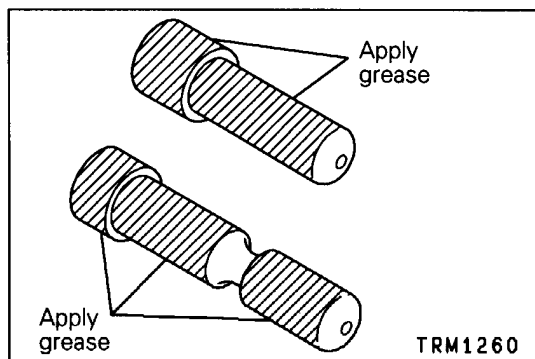

q **INSTALLATION OF NEUTRAL PLUNGERS A AND B**

(1) Apply grease to the sliding surfaces of the neutral plungers before installation.

Specified grease:

Mitsubishi genuine grease Part No. 0101011 or equivalent

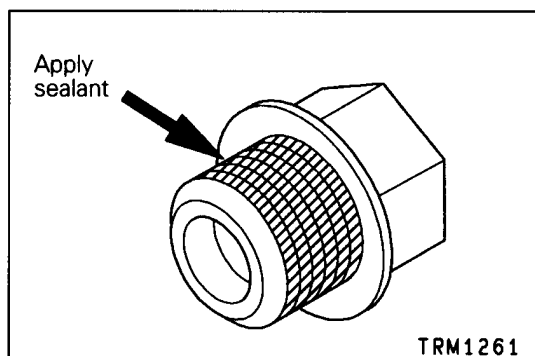

r **INSTALLATION OF SEAL PLUG (When reused)**

(1) Apply sealant to the threaded area of the seal plug before tightening to the specified torque.

Specified sealant: 3M ATD Part No. 8660 or equivalent

NOTE

Ensure that any old sealant still adhering to the seal plug is fully removed.

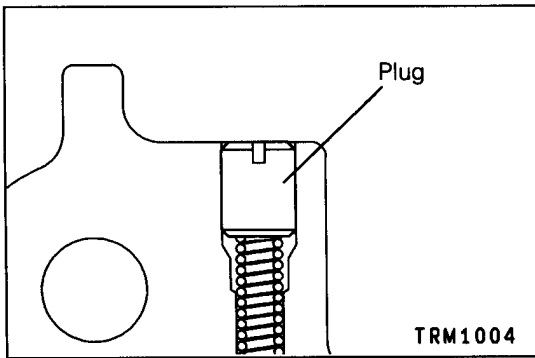

s INSTALLATION OF PLUG

- (1) Screw in the plug until its end is flush with the end face of the transfer case adapter.

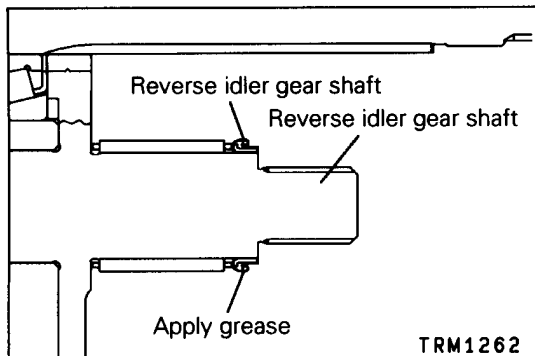

t INSTALLATION OF FRICTION DAMPER

- (1) Install the friction damper in the illustrated direction. After installation, apply grease to the surfaces brought into contact with the reverse idle gear.

Specified grease:

Mitsubishi genuine grease Part No. 0101011 or equivalent

u INSTALLATION OF TRANSFER

- (1) Apply grease to the splines in the main shaft and input gear.

Specified grease:

Mitsubishi genuine grease Part No. 0101011 or equivalent

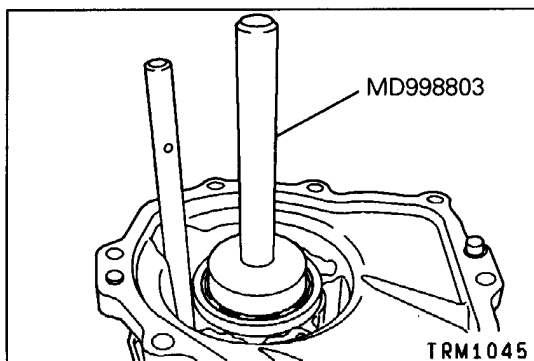

v INSTALLATION OF OIL SEAL

- (1) Use the indicated special tool to install the oil seal. After installation, pack the lip section of the oil seal with grease.

Specified grease:

Mitsubishi genuine grease Part No. 0101011 or equivalent

4. CONTROL HOUSING

V5M21-2 (KM147)

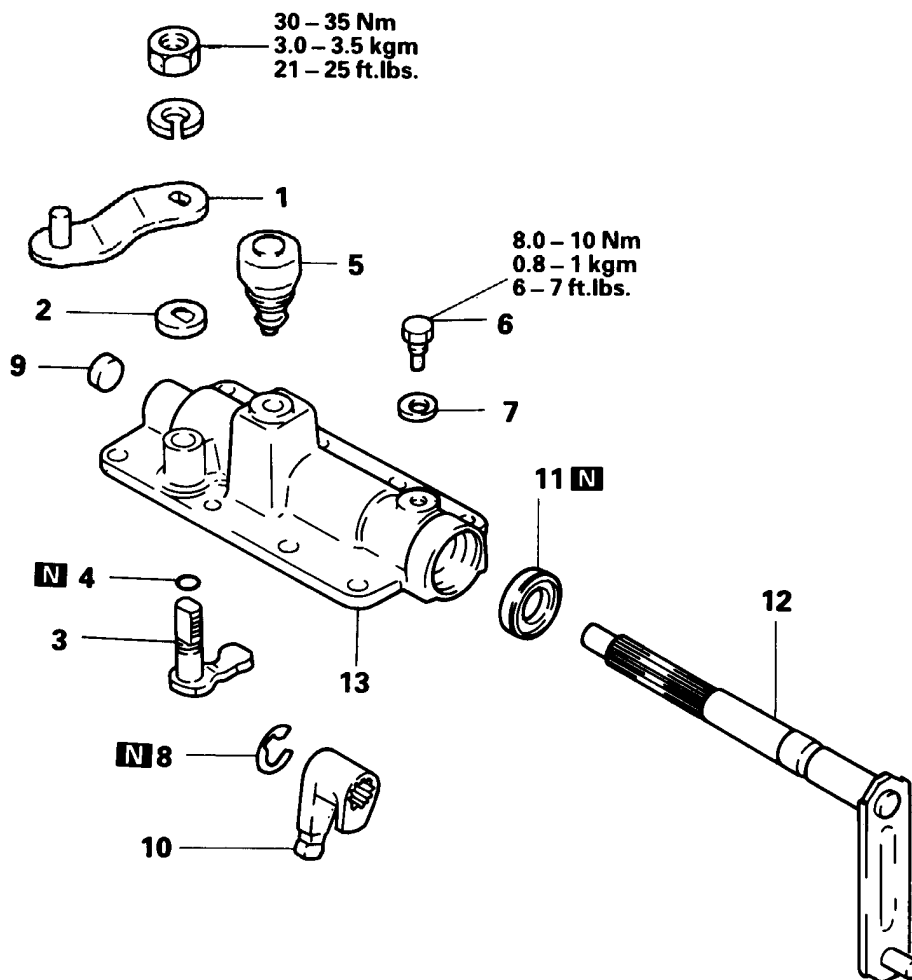

Disassembly steps

1. Select shaft lever
2. Baffle plate
3. Select shaft
4. O-ring
- A** 5. Air breather
6. Screw set
7. Spacer
8. Snap ring
9. Sealing cap
10. Change lever
11. Oil seal
12. Shift lever
13. Control housing

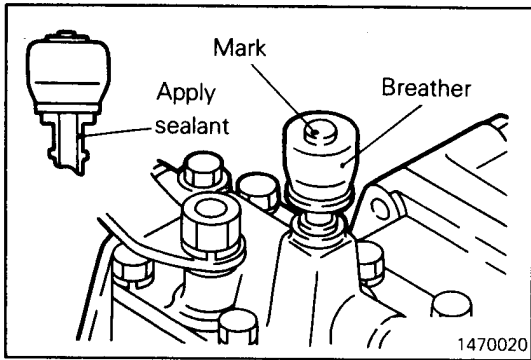
**SERVICE POINT OF REASSEMBLY****A APPLICATION OF SEALANT TO AIR BREATHER**

- (1) Apply specified sealant to air breather mounting portion.
- (2) Install the breather with identification mark toward the front and with cement applied to installed portion of housing.

Specified sealant:**3M Super Weatherstrip No. 8001 or equivalent**

5. CONTROL LEVER

R4M21-1 (KM130)

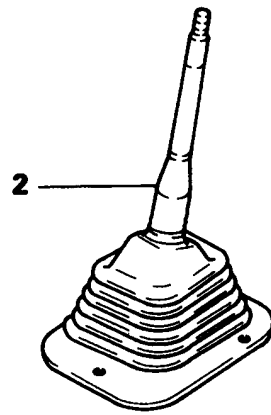

Disassembly steps

- 1. Bolt
- 2. Control lever
- 3. Lever bushing
- D 4. Gasket
- 5. Stopper plate
- 6. Extension housing cover

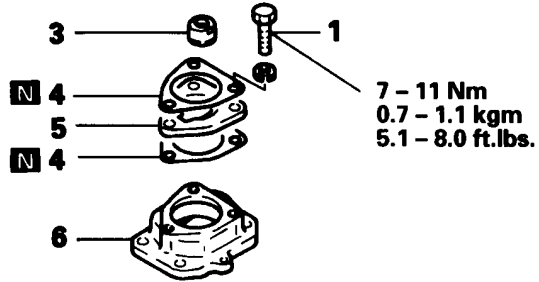

110050

R5M21-1, 3, 4, 5 (KM132), R5M21-7-G

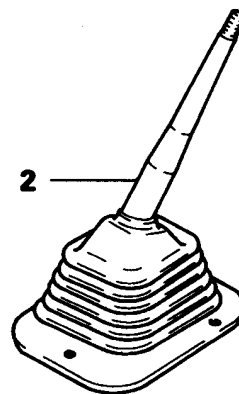

Disassembly steps

- 1. Bolt
- 2. Control lever
- 3. Lever bushing
- D 4. Gasket
- 5. Stopper plate
- 6. Nut
- A 7. Stopper bracket assembly
- A 8. Special bolt
- 9. Extension housing cover
- 10. Return spring

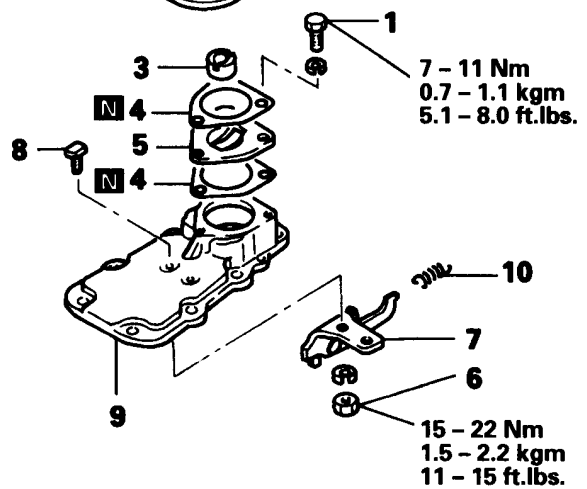

132046

V5M21-1, 4 (KM145)

Disassembly steps

- 1. Bolt
- 2. Control housing cover
- C** 3. Control housing cover gasket
- 4. Transfer control lever
- B** 5. Transmission control lever
- 6. Gasket
- 7. Stopper plate
- 8. Nut
- 9. Spring washer
- A** 10. Stopper bracket assembly
- 11. Return spring
- A** 12. Special bolt
- 13. Control housing

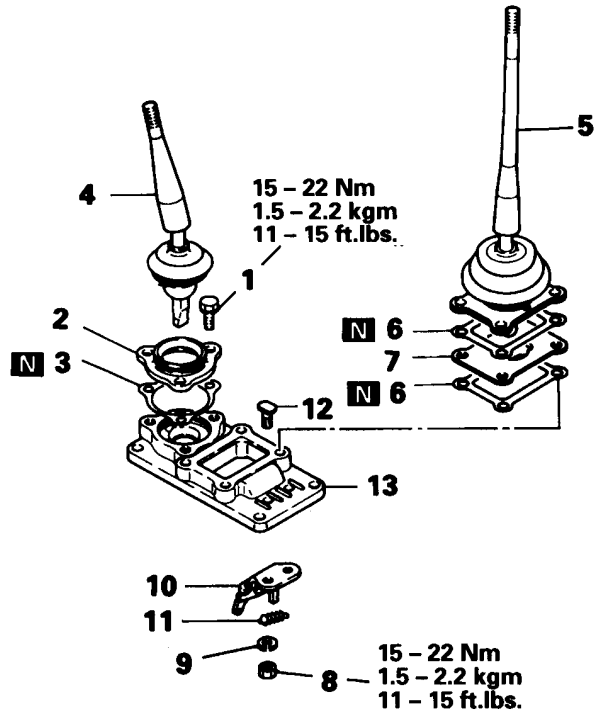

145042

V5M21-5, 6, 7, 9

Disassembly steps

- 1. Bolt
- C** 2. Control housing cover gasket
- 3. Control housing cover
- 4. Transfer control lever
- 5. Cover
- 6. Lever bushing
- B** 7. Control lever gasket
- 8. Stopper plate
- 9. Transmission control lever
- 10. Cover
- 11. Nut
- 12. Spring washer
- 13. Stopper bracket assembly
- A** 14. Special bolt
- 15. Control housing

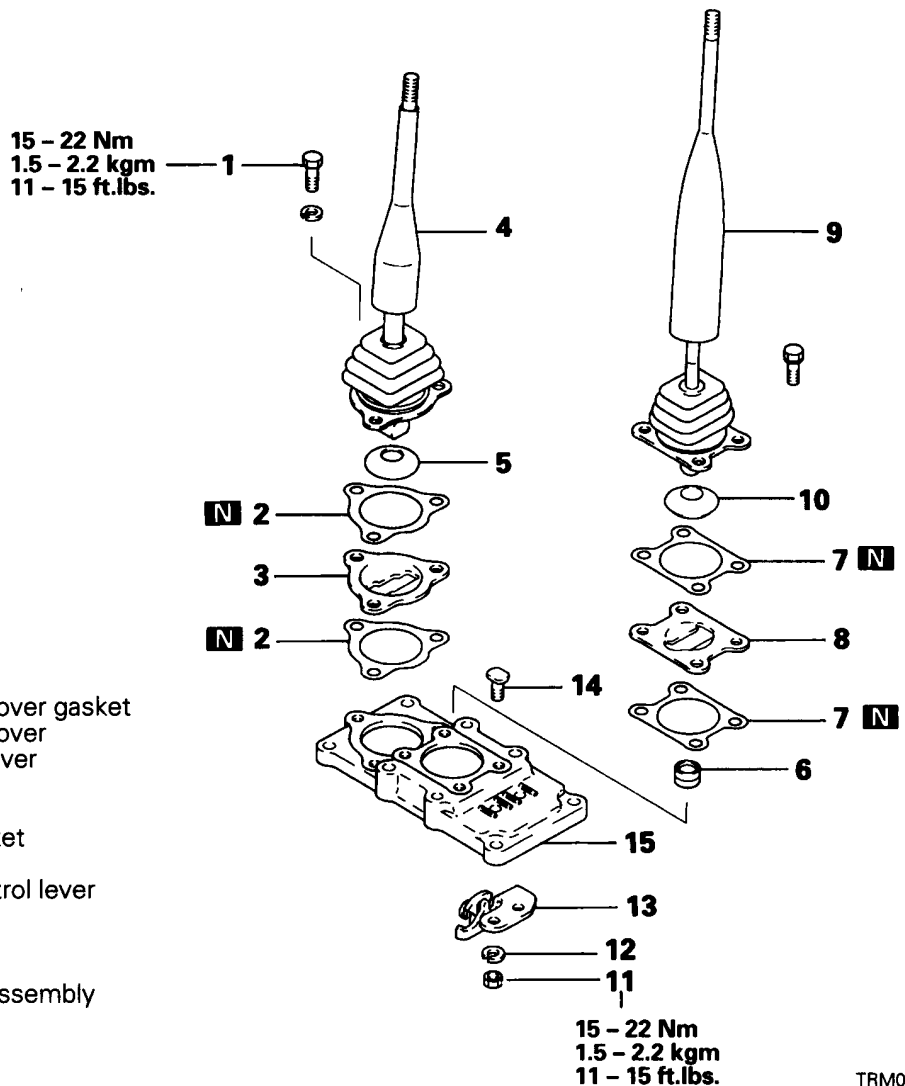

TRM0273

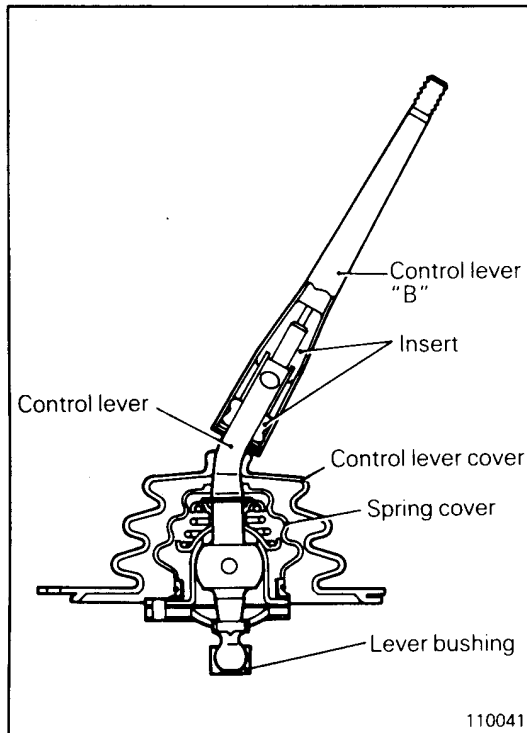

INSPECTION

- (1) Check for play between control lever and control lever "B". If play is evident, replace lever assembly.
- (2) Push control lever in and check to ensure that it moves smoothly up and down.
- (3) Check cover for damage and replace if necessary. To remove cover, cut away with knife. To install new cover, first apply thin coat of oil to periphery of control lever "B". Then install by sliding it down from Top of lever "B".
- (4) Check lever bushing for wear and replace if necessary.

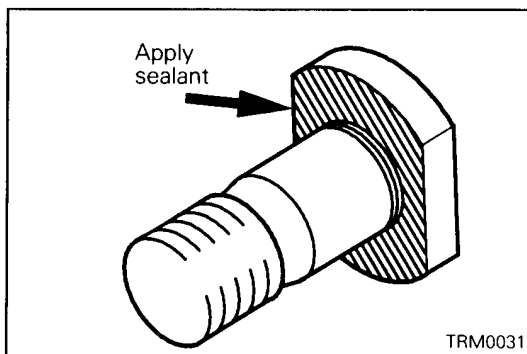

SERVICE POINTS OF REASSEMBLY

A APPLICATION OF SEALANT TO SPECIAL BOLT

Specified sealant:
3M ATD Part No. 8660 or equivalent

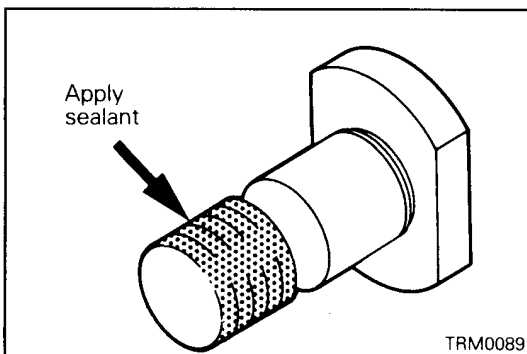

Specified sealant:
3M Scotch Grip No. 2353 or equivalent

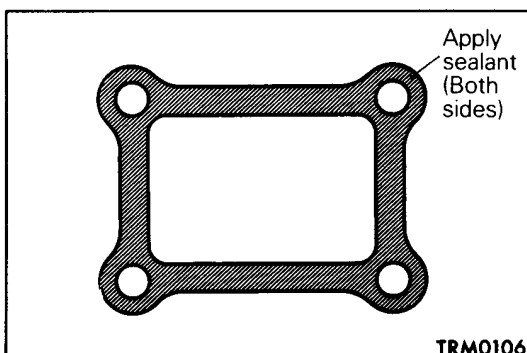

B APPLICATION OF SEALANT TO GASKET

Specified sealant:
Mitsubishi genuine sealant Part No. 997740 or equivalent

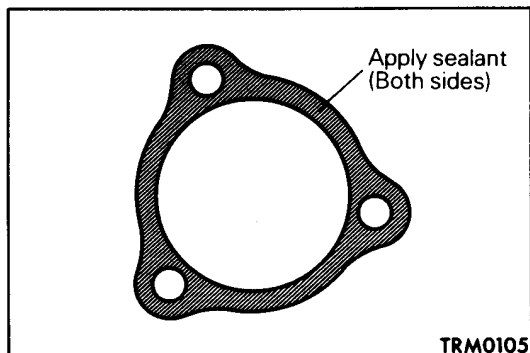

C APPLICATION OF SEALANT TO CONTROL HOUSING COVER GASKET

Specified sealant:

Mitsubishi genuine sealant Part No. 997740 or equivalent

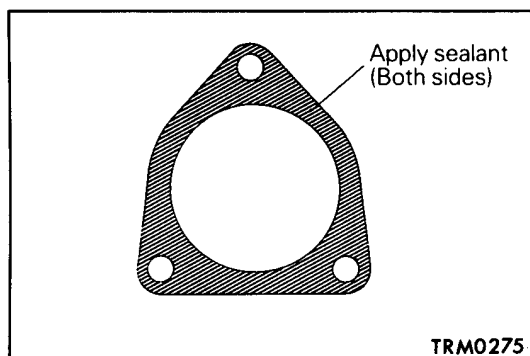

D APPLICATION OF SEALANT TO GASKET

Specified sealant:

Mitsubishi genuine sealant Part No. 997740 or equivalent

6. COUNTERSHAFT

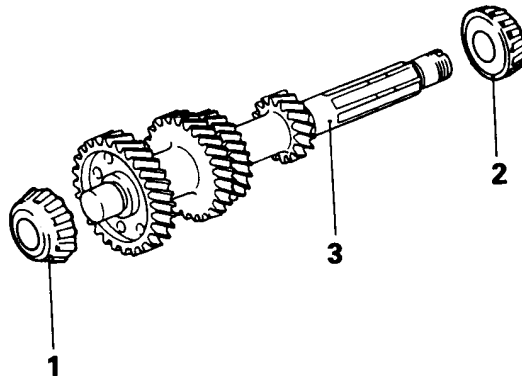

Disassembly steps

- Ⓐ Ⓐ 1. Countershaft front bearing
- Ⓐ Ⓐ 2. Countershaft center bearing
- 3. Countershaft gear

132069

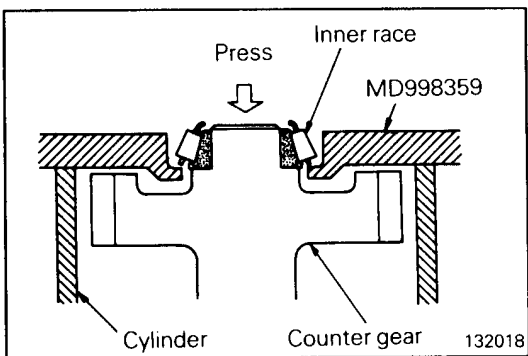

SERVICE POINT OF DISASSEMBLY

- Ⓐ REMOVAL OF COUNTERSHAFT BEARINGS

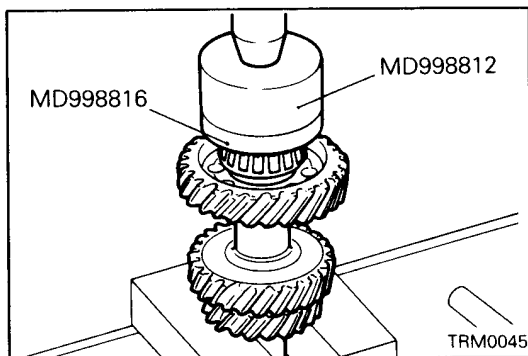

SERVICE POINT OF REASSEMBLY

- Ⓐ PRESS-FIT OF COUNTERSHAFT BEARINGS

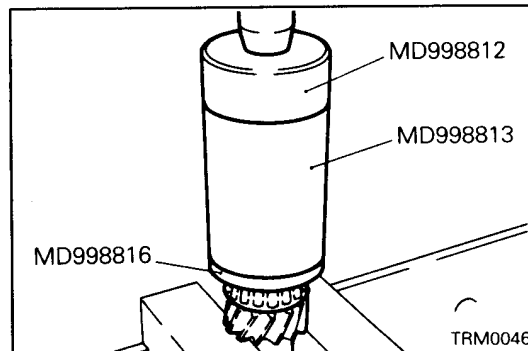

7. EXTENSION HOUSING

R4M21-1 (KM130)

Disassembly steps

- 1. Return spring
- Ⓐ Ⓒ 2. Spring pin
- 3. Control shaft
- 4. Change shifter
- 5. Return spring plunger
- 6. Neutral return spring
- 7. Dust seal guard
- Ⓐ 8. Oil seal
- 9. Extension housing

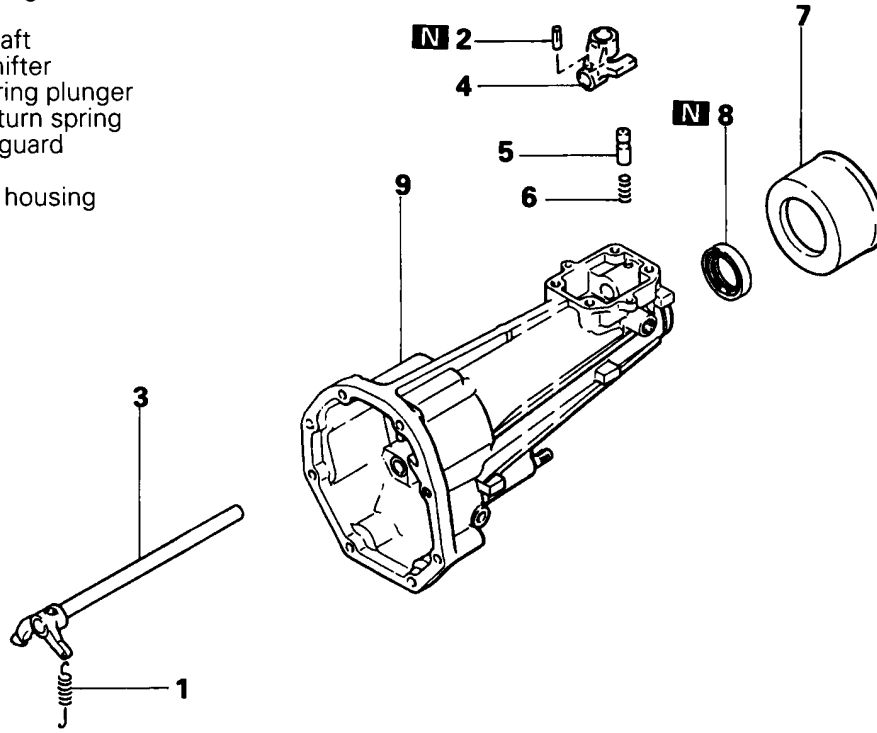

TRM0090

R5M21-1, 4 (KM132)

Disassembly steps

- Ⓑ Ⓓ 1. Lock pin
- Ⓑ Ⓓ 2. Spring pin
- 3. Control finger and control shaft
- 4. Neutral return finger
- 5. Change shifter
- 6. Dust seal guard
- Ⓐ 7. Oil seal
- 8. Extension housing

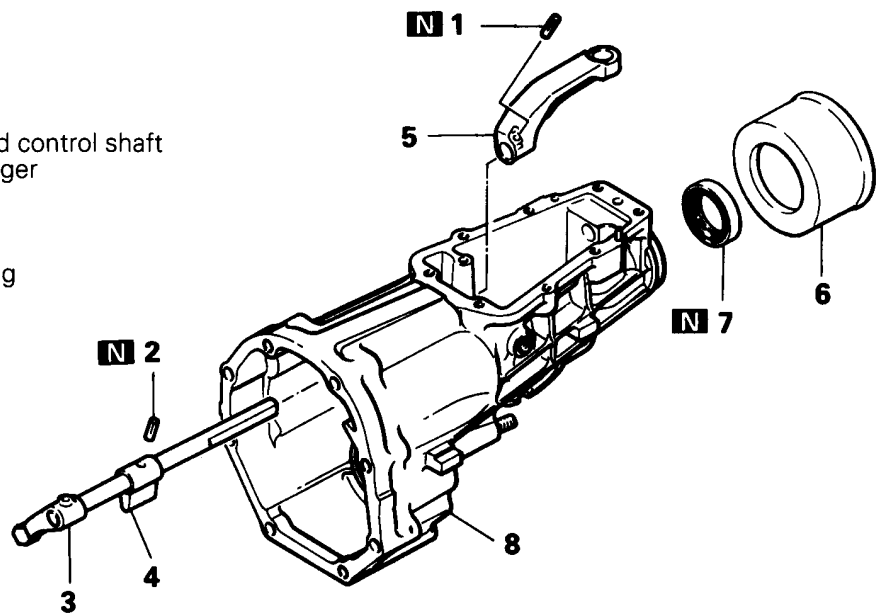

132040

R4M21-2 (KM131)

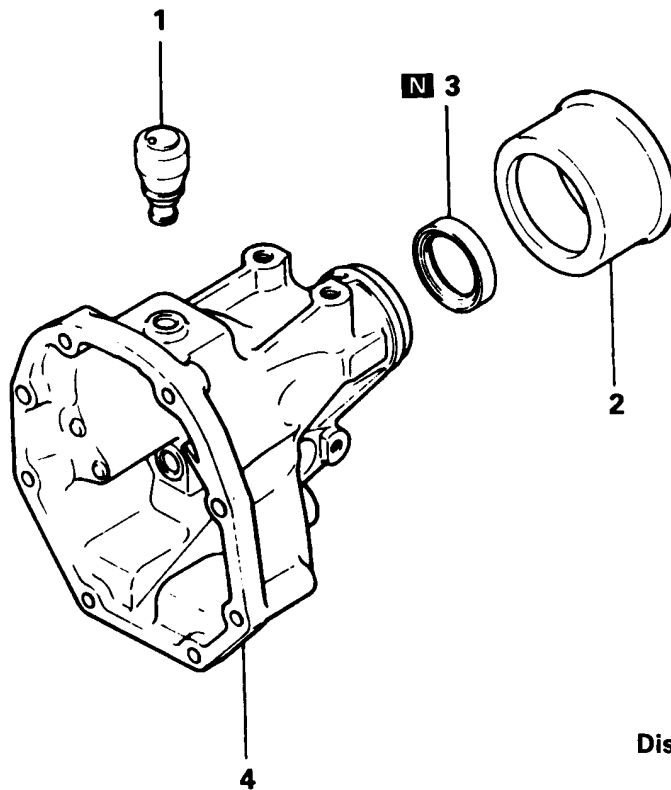

Disassembly steps

- B** 1. Air breather
- 2. Dust seal guard
- A** 3. Oil seal
- 4. Extension housing

1310008

R5M21-2, 3, 8 (KM135)

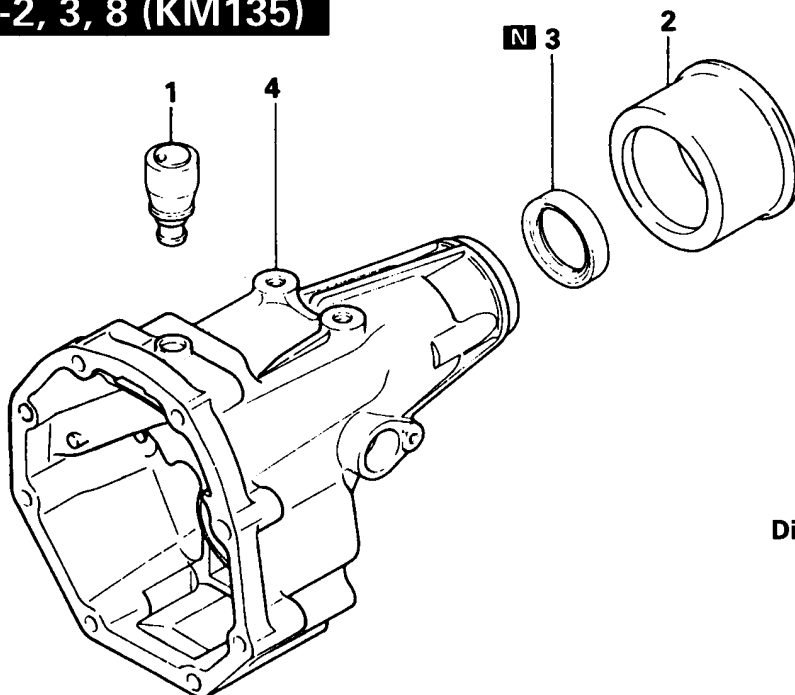

Disassembly steps

- B** 1. Air breather
- 2. Dust seal guard
- A** 3. Oil seal
- 4. Extension housing

1350013

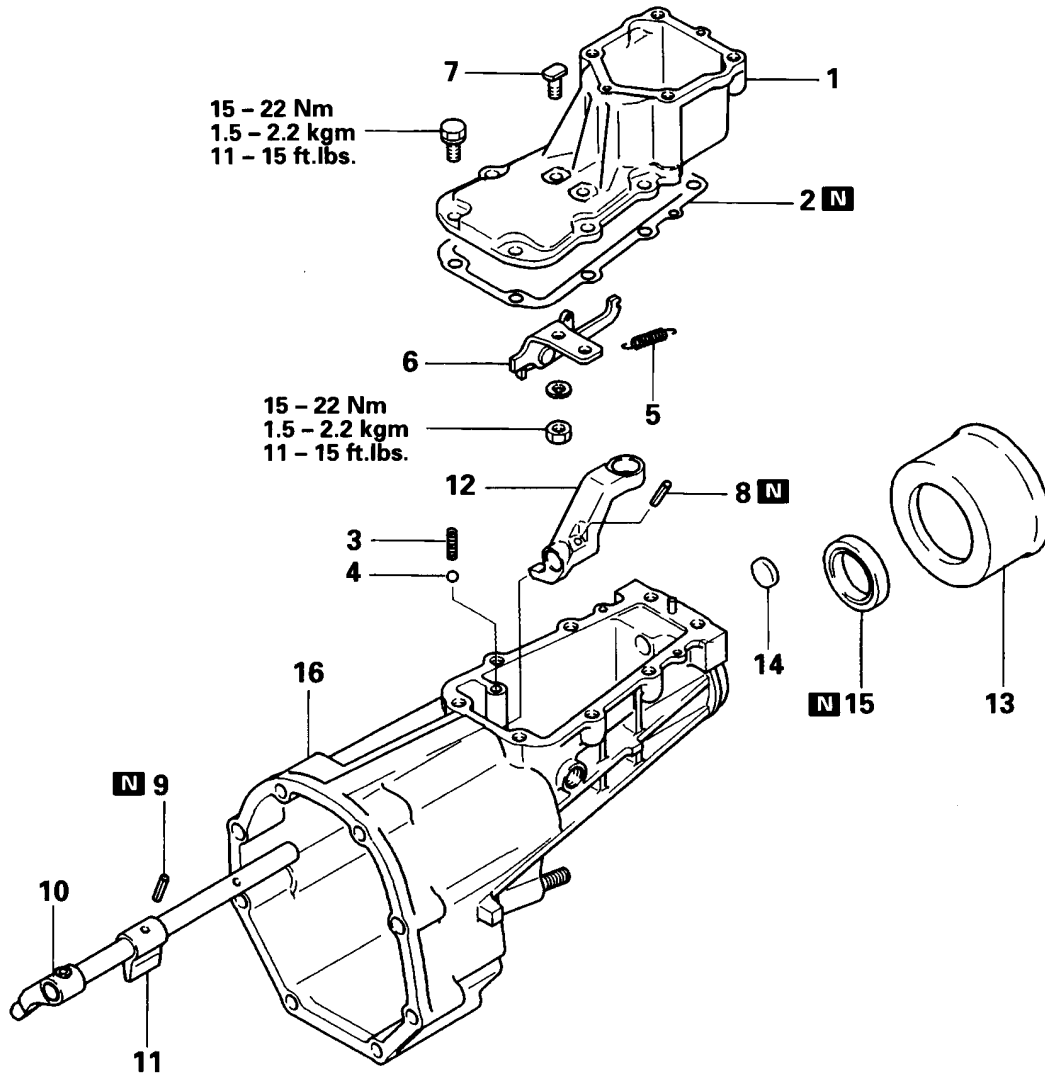

Disassembly steps

- | | |
|--|--|
| <p>1. Extension housing cover</p> <p>2. Extension housing cover gasket</p> <p>3. Resistance spring</p> <p>4. Steel ball</p> <p>5. Return spring</p> <p>6. Stopper bracket</p> <p>H 7. Special bolt</p> <p>8. Lock pin</p> | <p>G 9. Spring pin</p> <p>10. Control shaft</p> <p>11. Neutral return finger</p> <p>12. Change shifter</p> <p>13. Dust seal guard</p> <p>F 14. Control shaft cap</p> <p>E 15. Oil seal</p> <p>16. Extension housing</p> |
|--|--|

R5M21-7-E, Q

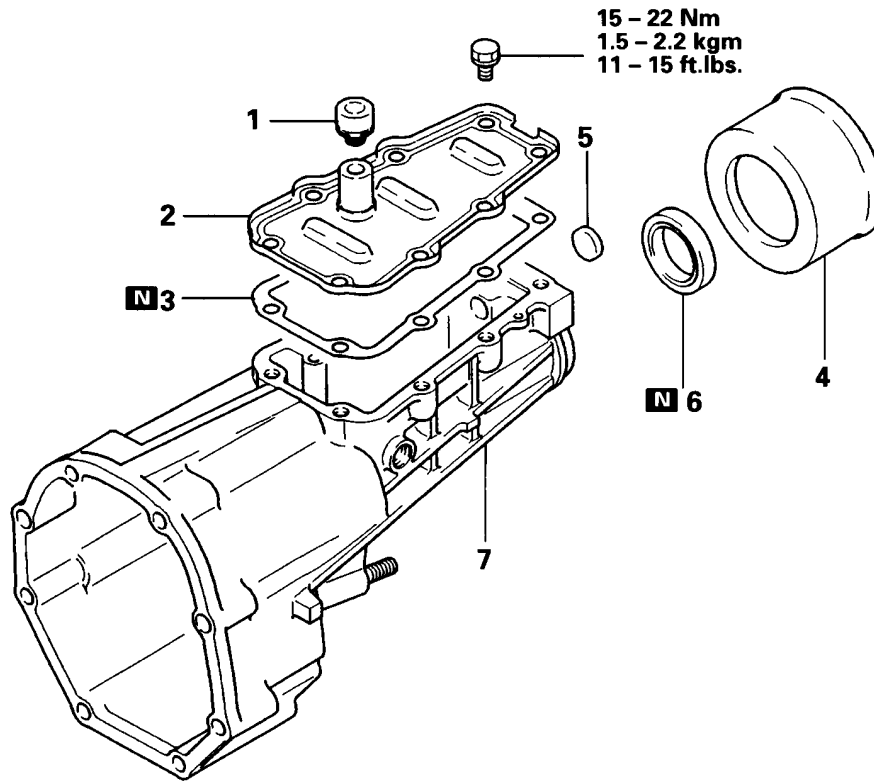
**Disassembly steps**

- I** 1. Air breather
- 2. Extension housing cover
- 3. Extension housing cover gasket
- 4. Dust seal guard
- F**
- E** 5. Control shaft cap
- 6. Oil seal
- 7. Extension housing

TRM0625

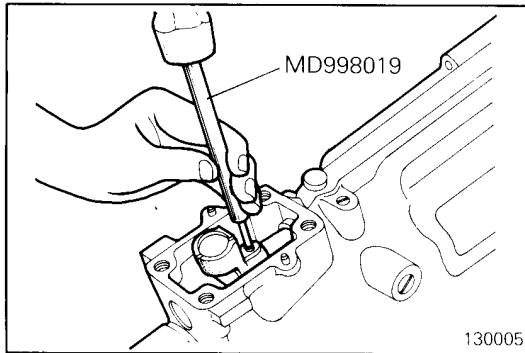

SERVICE POINTS OF DISASSEMBLY

Ⓐ REMOVAL OF SPRING PIN

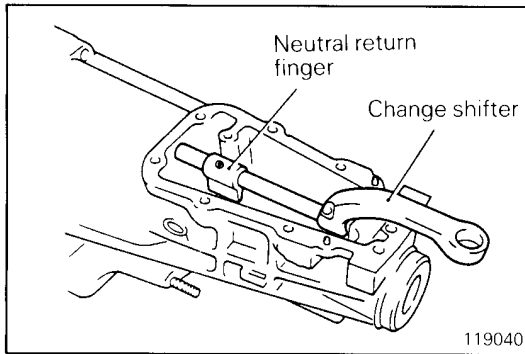

Ⓑ REMOVAL OF LOCK PIN / SPRING PIN

- (1) To remove control shaft from extension housing, remove lock pin from neutral return finger and remove spring pin from change shifter with the special tool, Lock Pin Extractor. Then remove control shaft toward front of housing.

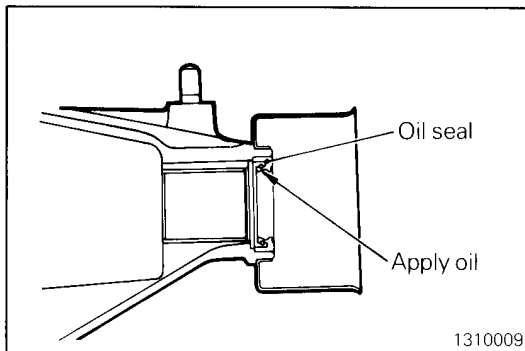

SERVICE POINTS OF REASSEMBLY

Ⓐ INSTALLATION OF OIL SEAL

- (1) Apply oil to the lip of oil seal.

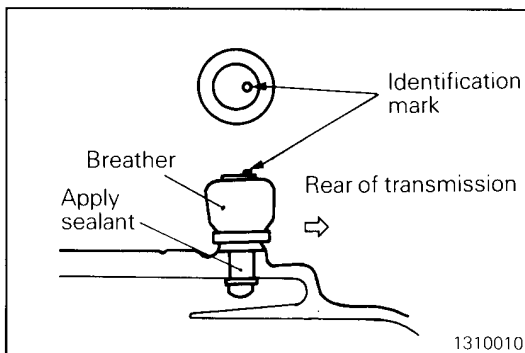

Ⓑ APPLICATION OF SEALANT TO AIR BREATHER

- (1) Apply specified sealant to air breather.

Specified sealant:

3M Super Weatherstrip No. 8001 or equivalent

- (2) Install the air breather with the identification mark toward the rear.

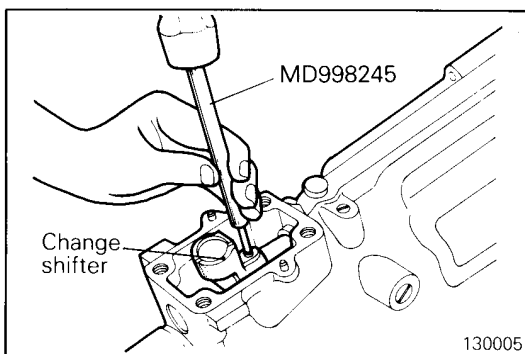

Ⓒ INSTALLATION OF SPRING PIN

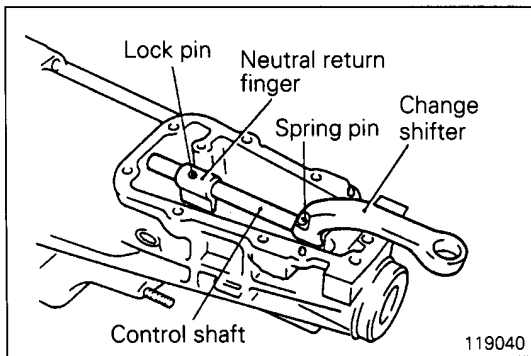
**D INSTALLATION OF SPRING PIN / LOCK PIN**

- (1) Align pin holes of control shaft, neutral return finger and change shifter. Using the special tool, Lock Pin Installer, install lock pin and spring pin.

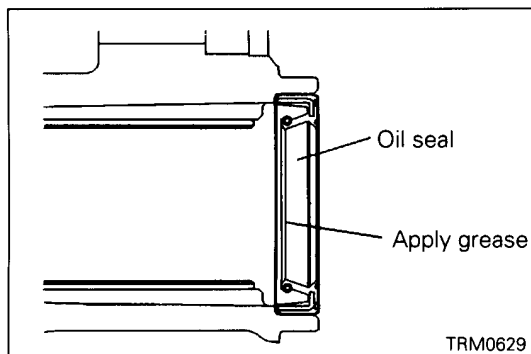
**E INSTALLATION OF OIL SEAL**

- (1) After installation, pack grease between the lips of the oil seal.

Specified grease:

Mitsubishi genuine grease Part No. 0101011 or equivalent

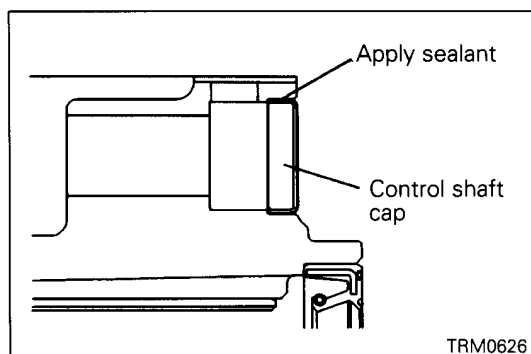
**F INSTALLATION OF CONTROL SHAFT CAP**

- (1) Apply sealant to the entire circumference of the control shaft cap and press in the cap until it becomes flat with the extension housing.

Specified sealant:

3M ATD Part No. 8660 or equivalent

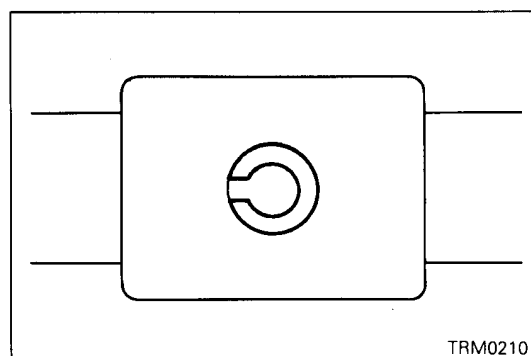
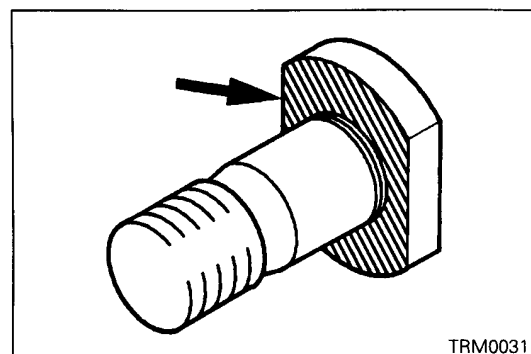
**G INSTALLATION OF SPRING PIN****H INSTALLATION OF SPECIAL BOLT**

- (1) Apply sealant to the extension housing cover mounting surface and the bolt threads.

Specified sealant:

3M ATD Part No. 8660 or equivalent

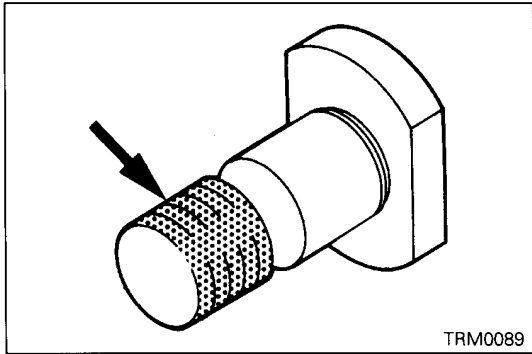

Specified sealant:
3M ATD Part No. 2353 or equivalent

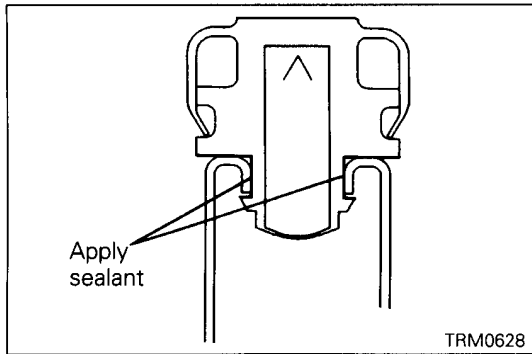

I INSTALLATION OF AIR BREATHER

Specified sealant:
3M Super Weatherstrip No. 8001 or equivalent

8. MAINDRIVE GEAR

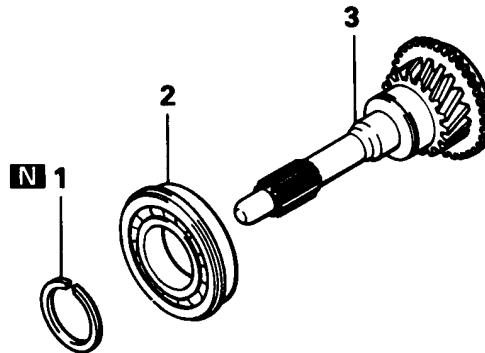

Disassembly steps

- B** 1. Snap ring
- A** 2. Bearing
- 3. Maindrive gear

110038

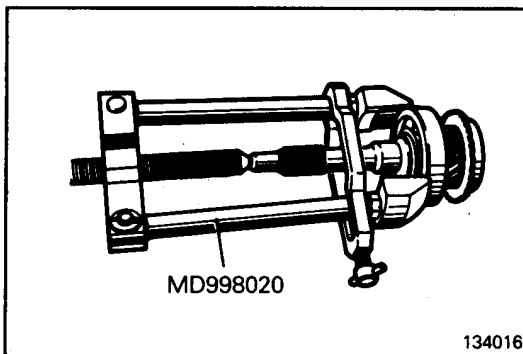

SERVICE POINT OF DISASSEMBLY

- A** REMOVAL OF BEARING

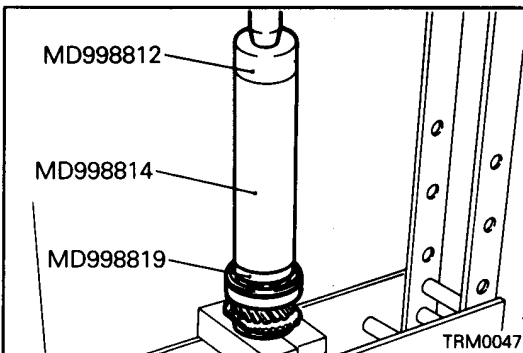

SERVICE POINTS OF REASSEMBLY

- A** INSTALLATION OF BEARING

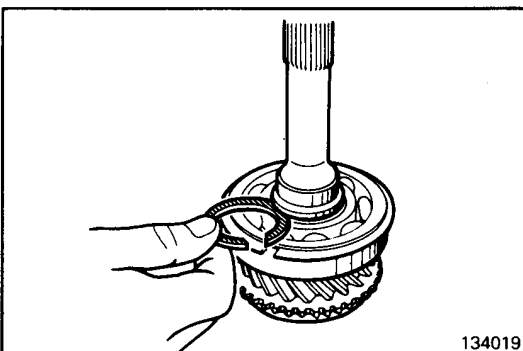

B INSTALLATION OF SNAP RING

- (1) Select and install the maindrive gear snap ring of such thickness that will minimize clearance between the snap ring and bearing. In other words, install the thickest snap ring that can fit in snap ring groove.

Standard value:

0 – 0.06 mm (0 – 0.0024 in.)

9. MAINSHAFT

R4M21-1, R5M21-1, 2, 3, R5M21-4-K, R5M21-5, R5M21-7-E, Q (KM130, KM132-B, G, I, M, N)

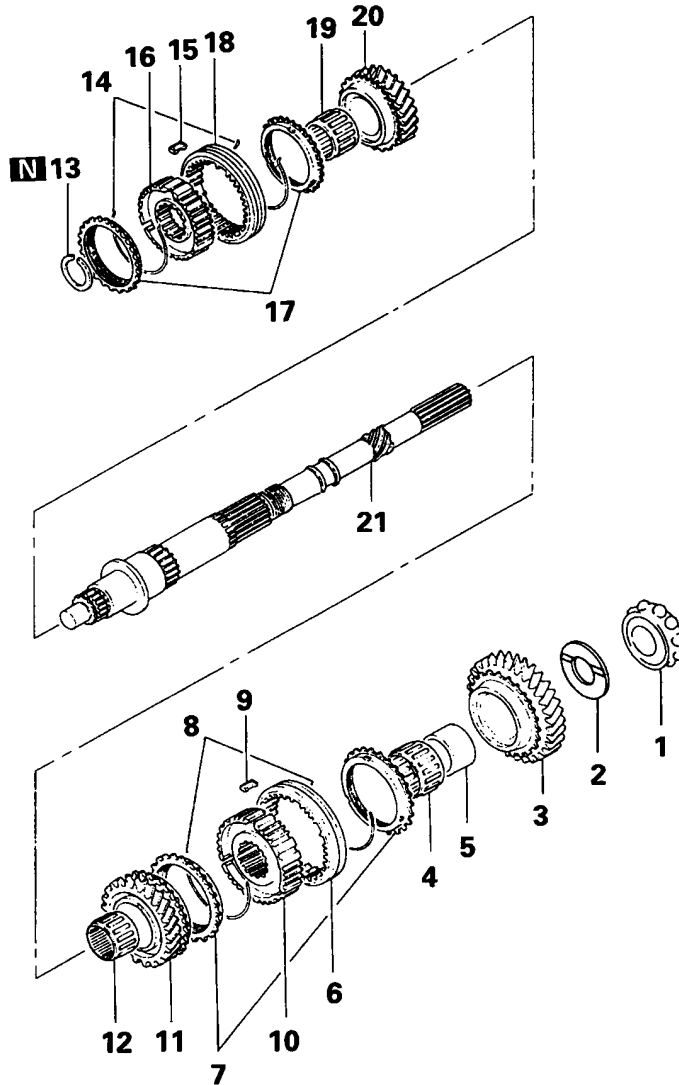

Disassembly steps

- | | |
|--|--|
| <p>Ⓐ ⓓ 1. Ball bearing inner race
(KM132-B, G, I, M, N, R5M21-1-G,
R5M21-4-K, R5M21-5-G, R5M21-7-Q)</p> <p>2. Spacer (except KM132-M, N, R5M21-1-G,
R5M21-4-K, R5M21-5-G, R5M21-7-Q)</p> <p>3. 1st speed gear</p> <p>Ⓑ 4. Needle bearing</p> <p>5. Bearing sleeve</p> <p>Ⓑ 6. 1st-2nd speed synchronizer sleeve</p> <p>7. Synchronizer ring</p> <p>Ⓑ 8. Synchronizer spring</p> <p>Ⓑ 9. Synchronizer key</p> | <p>10. 1st-2nd speed synchronizer hub</p> <p>11. 2nd speed gear</p> <p>12. Needle bearing</p> <p>Ⓒ 13. Snap ring</p> <p>Ⓑ 14. Synchronizer spring</p> <p>Ⓑ 15. Synchronizer key</p> <p>Ⓐ 16. 3rd-4th speed synchronizer hub</p> <p>Ⓐ 17. Synchronizer ring</p> <p>18. 3rd-4th speed synchronizer sleeve</p> <p>19. Needle bearing</p> <p>20. 3rd speed gear</p> <p>21. Mainshaft</p> |
|--|--|

R5M21-2, R5M21-8-E, Q (KM131, 135)

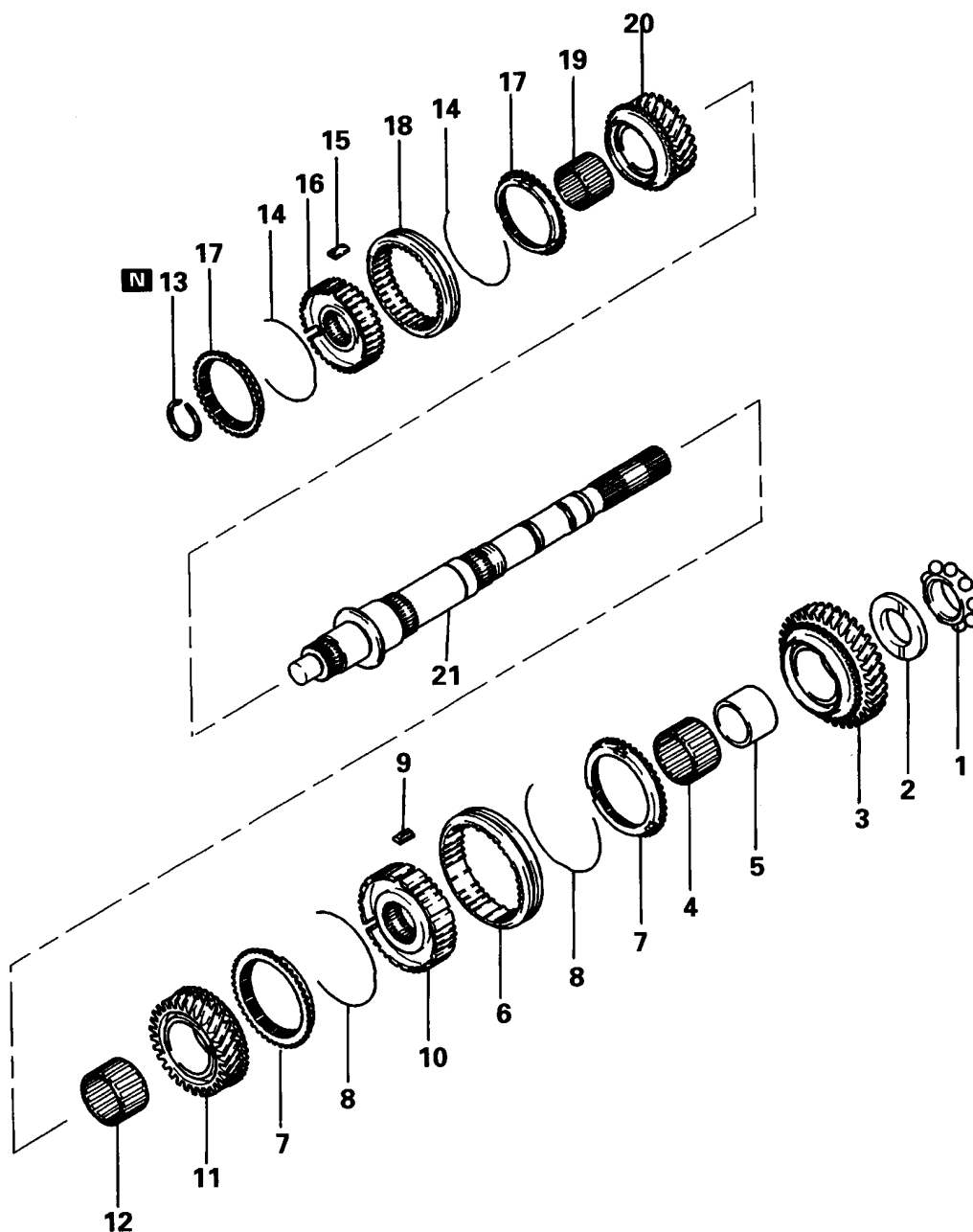
**Disassembly steps**

- | | |
|--|---|
| <p>Ⓐ 1. Bearing inner race (KM135, R5M21-2-G, P, Q, R5M21-8-Q)</p> <p>2. Spacer (except KM135, R5M21-2-G, P, Q, R5M21-8-Q)</p> <p>3. 1st speed gear</p> <p>4. Needle bearing</p> <p>Ⓑ 5. Bearing sleeve</p> <p>6. 1st-2nd speed synchronizer sleeve</p> <p>7. Synchronizer ring</p> <p>Ⓑ 8. Synchronizer spring</p> <p>Ⓑ 9. Synchronizer key</p> <p>10. 1st-2nd speed synchronizer hub</p> | <p>11. 2nd speed gear</p> <p>12. Needle bearing</p> <p>Ⓒ 13. Snap ring</p> <p>Ⓑ 14. Synchronizer spring</p> <p>Ⓑ 15. Synchronizer key</p> <p>Ⓐ 16. 3rd-4th speed synchronizer hub</p> <p>17. Synchronizer ring</p> <p>Ⓐ 18. 3rd-4th speed synchronizer hub</p> <p>19. Needle bearing</p> <p>20. 3rd-4th speed gear</p> <p>21. Mainshaft</p> |
|--|---|

TRM0773

V5M21 EXCEPT V5M21-7-G (KM145, KM147)

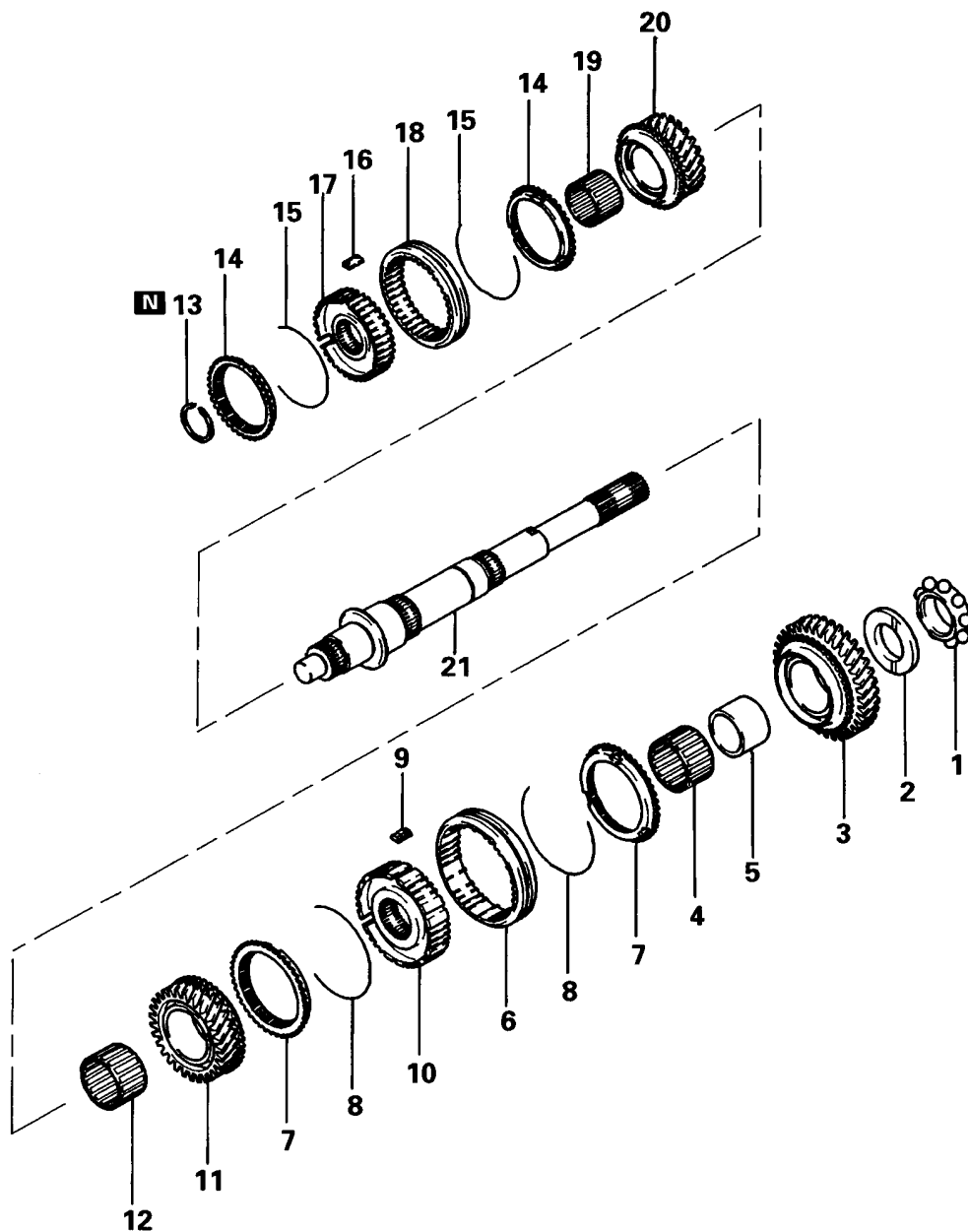

Disassembly steps

- | | |
|--|---|
| <p>(A) (D) 1. Ball bearing inner race
(KM145-8, 9, B, D, KM145-5, 7,
V5M21-1-G, J, Q, V5M21-2-G, Q,
V5M21-4-Q, V5M21-5, 6, V5M21-7-Q)</p> <p>2. Spacer (except KM145-8, 9, B, D,
KM145-5, 7, V5M21-G, J, Q,
V5M21-2-G, Q, V5M21-4-Q, V5M21-5, 6,
V5M21-7-Q)</p> <p>3. 1st speed gear</p> <p>4. Needle bearing</p> <p>(B) 5. Bearing sleeve</p> <p>6. 1st-2nd speed synchronizer sleeve</p> <p>7. Synchronizer ring</p> <p>(B) 8. Synchronizer spring</p> | <p>(B) 9. Synchronizer key</p> <p>10. 1st-2nd speed synchronizer hub</p> <p>11. 2nd speed gear</p> <p>12. Needle bearing</p> <p>(C) 13. Snap ring</p> <p>14. Synchronizer ring</p> <p>(B) 15. Synchronizer spring</p> <p>(B) 16. Synchronizer key</p> <p>(A) 17. 3rd-4th speed synchronizer hub</p> <p>(A) 18. 3rd-4th speed synchronizer sleeve</p> <p>19. Needle bearing</p> <p>20. 3rd speed gear</p> <p>21. Mainshaft</p> |
|--|---|

TRM0774

R5M21-7-G, V5M21-7-G, V5M21-A

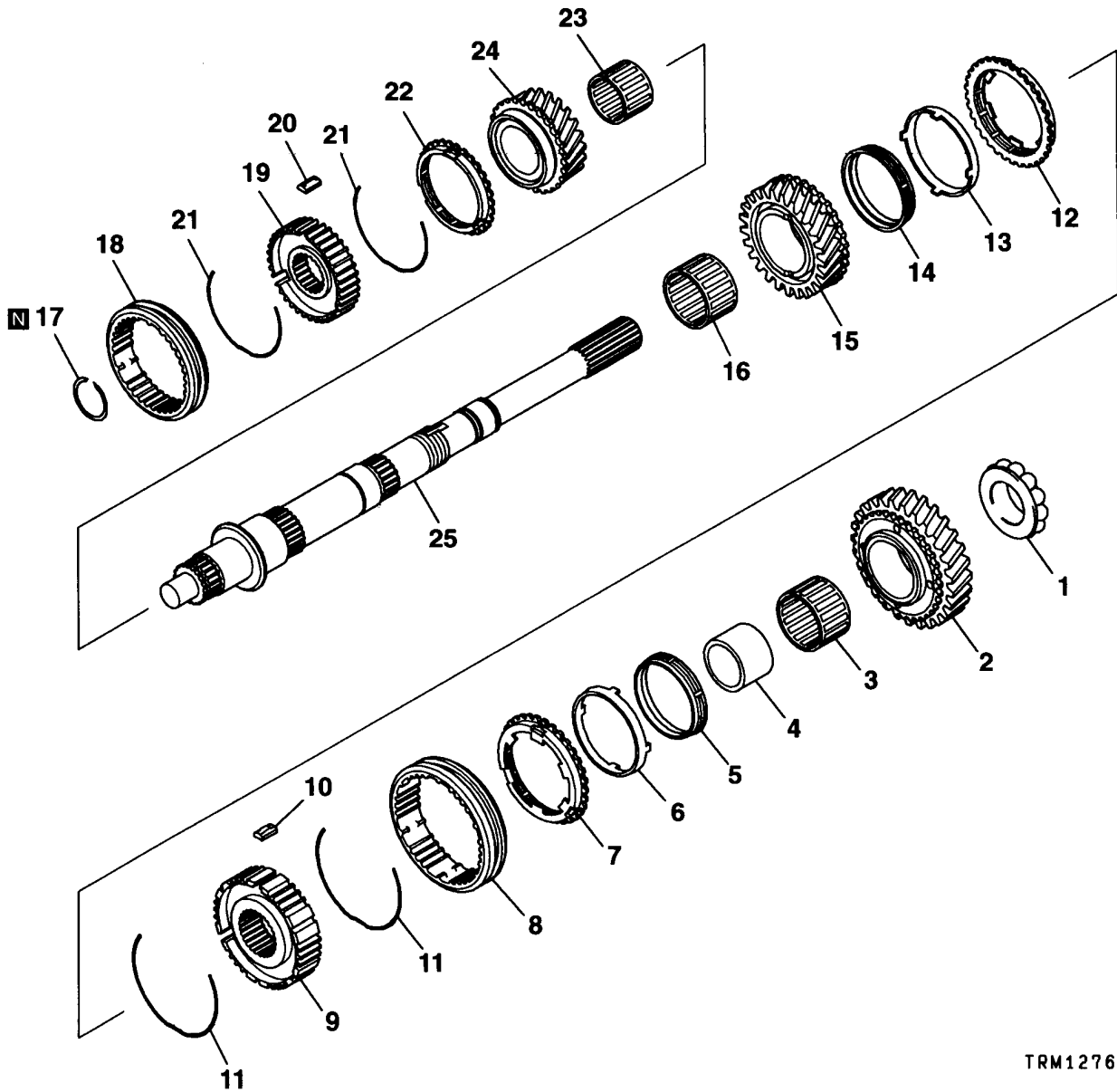

TRM1276

Disassembly steps

- | | |
|---|---|
| <p>Ⓐ Ⓓ 1. Ball bearing inner race
2. 1st speed gear
3. Needle bearing</p> <p>Ⓑ Ⓔ 4. Bearing sleeve
5. Synchronizer inner race
6. Synchronizer cone
7. Synchronizer outer race</p> <p>Ⓕ 8. 1st-2nd synchronizer sleeve
Ⓖ 9. 1st-2nd synchronizer hub
Ⓗ 10. Synchronizer key
Ⓘ 11. Synchronizer spring</p> <p>Ⓙ 12. Synchronizer outer race
13. Synchronizer cone</p> | <p>14. Synchronizer inner race
15. 2nd speed gear
16. Needle bearing</p> <p>Ⓒ 17. Snap ring
Ⓐ 18. 3rd-4th synchronizer sleeve
Ⓐ 19. 3rd-4th synchronizer hub
Ⓑ 20. Synchronizer key
Ⓑ 21. Synchronizer spring
22. Synchronizer ring
23. 3rd speed gear
24. Needle bearing
25. Mainshaft</p> |
|---|---|

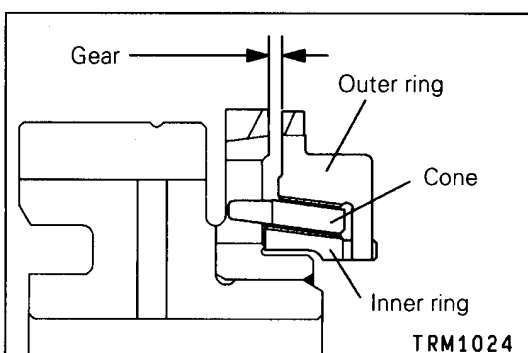
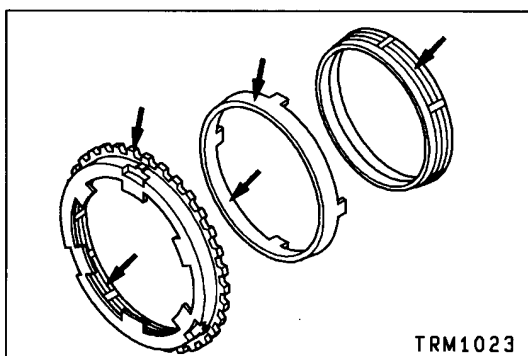
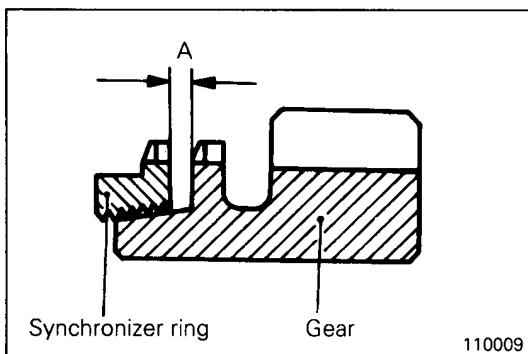
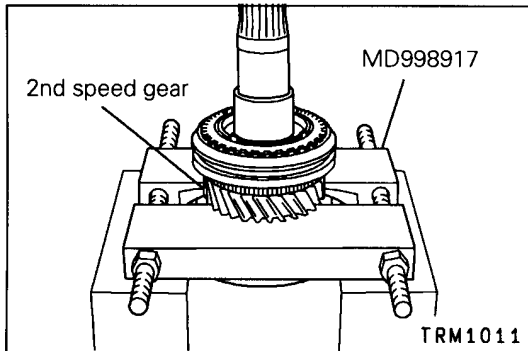
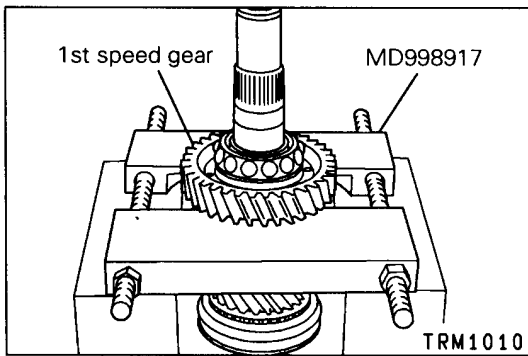

SERVICE POINTS OF DISASSEMBLY

Ⓐ REMOVAL OF BALL BEARING INNER RACE

- (1) Support the 1st speed gear on the special tool as illustrated.
- (2) Remove the ball bearing inner race using a press.

Ⓑ REMOVAL OF BEARING SLEEVE

- (1) Support the 2nd speed gear on the special tool as illustrated.
- (2) Remove the bearing sleeve using a press.

INSPECTION

SYNCHRONIZER RING

- (1) Check the synchronizer ring for worn and damaged internal threads.
- (2) With synchronizer assembled to cone of each gear, check dimension "A". If dimension "A" exceeds the limit, replace the synchronizer ring and/or gear.

Limit: 0.5 mm (0.020 in.)

OUTER SYNCHRONIZER RING / INNER SYNCHRONIZER RING / SYNCHRONIZER CONE

- (1) Check to ensure that the clutch gear tooth surfaces and cone surfaces are not damaged and broken.

- (2) Install the outer ring, inner ring and cone, press them against the gear, and check clearance "A". If "A" is less than the limit, replace.

Limit: 0.3 mm (0.012 in.)

Caution

- **When any of the outer ring, inner ring or cone has to be replaced, replace them as a set.**

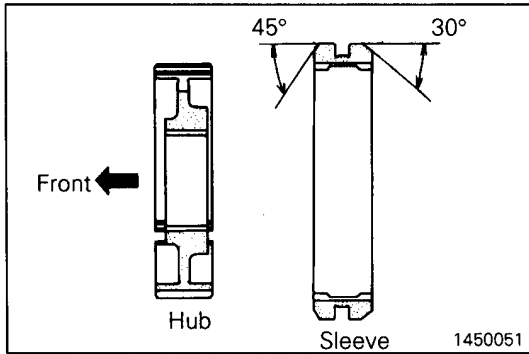

SERVICE POINTS OF REASSEMBLY

A INSTALLATION OF 3RD-4TH SPEED SYNCHRONIZER SLEEVE / 3RD-4TH SPEED SYNCHRONIZER HUB

- (1) Assemble the synchronizer hub and sleeve. Make sure that the hub and sleeve slide smoothly.

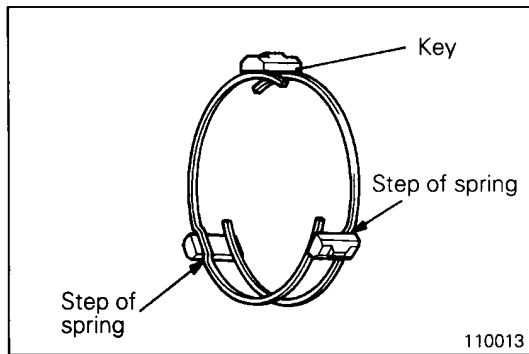

B INSTALLATION OF SYNCHRONIZER KEY / SYNCHRONIZER SPRING

- (1) Install two synchronizer springs. When installing springs, make sure that steps of front and rear springs are positioned on synchronizer key, but not on the same key.

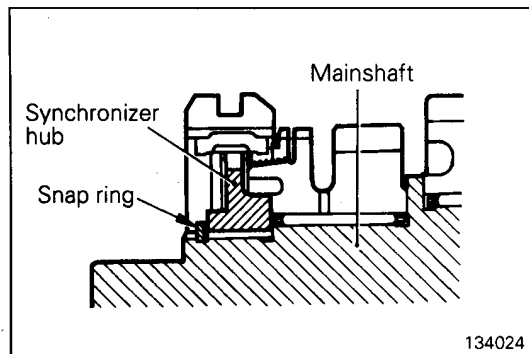

C INSTALLATION OF SNAP RING

- (1) Select and install the snap ring so that the synchronizer hub end play may reach the standard value.

Standard value: 0 – 0.08 mm (0 – 0.003 in.)

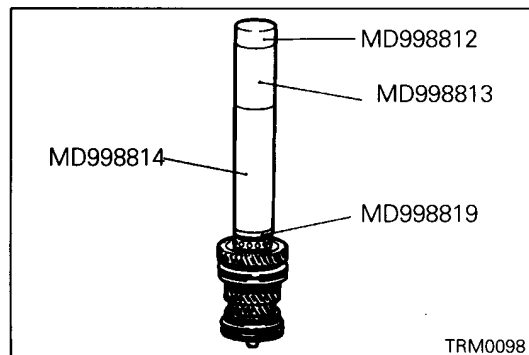

D INSTALLATION OF BALL BEARING INNER RACE

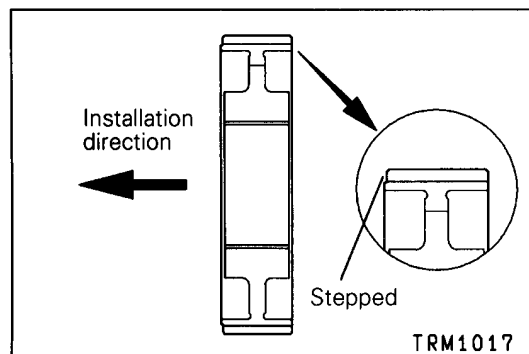

E INSTALLATION OF SYNCHRONIZER HUB

- (1) Install the synchronizer hub in the illustrated direction.

Caution

- Use care that the synchronizer ring may not be caught in the hub.

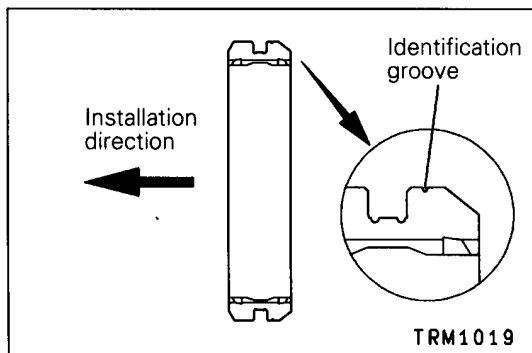

F INSTALLATION OF SYNCHRONIZER SLEEVE

- (1) Install the synchronizer sleeve in the illustrated direction.

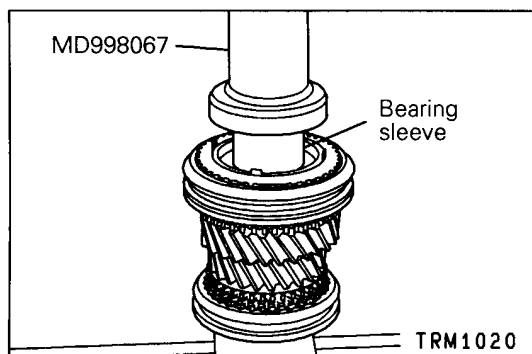

G INSTALLATION OF BEARING SLEEVE

- (1) Use the special tool to install the bearing sleeve.

10. SPEEDOMETER GEAR

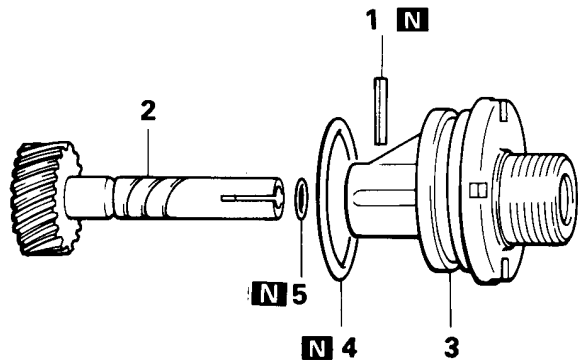

Disassembly steps

- ◆A◆ 1. Spring pin
- 2. Driven gear
- 3. Sleeve
- 4. O-ring
- 5. O-ring

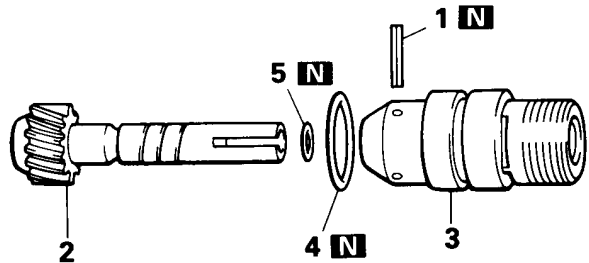

117003

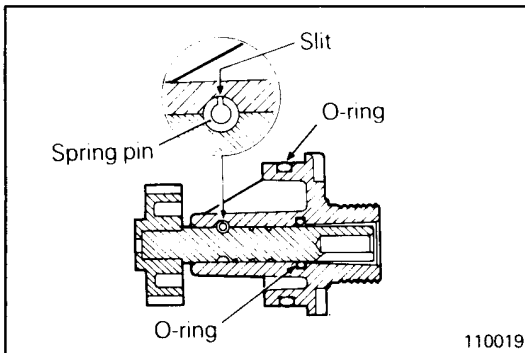

SERVICE POINT OF REASSEMBLY

◆A◆ INSTALLATION OF SPRING PIN

- (1) Drive the spring pin in, while making sure that slit does not face gear shaft.

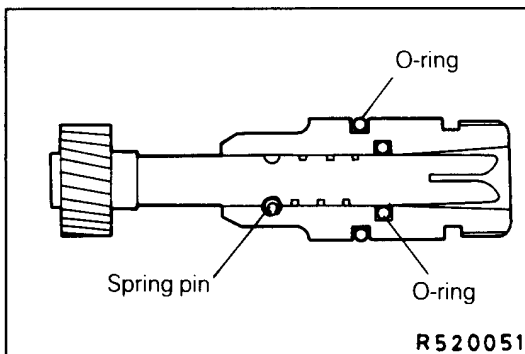

11. TRANSFER
<EXCEPT V5M21-A>

KM145, KM147, V5M21-1, 2, 4

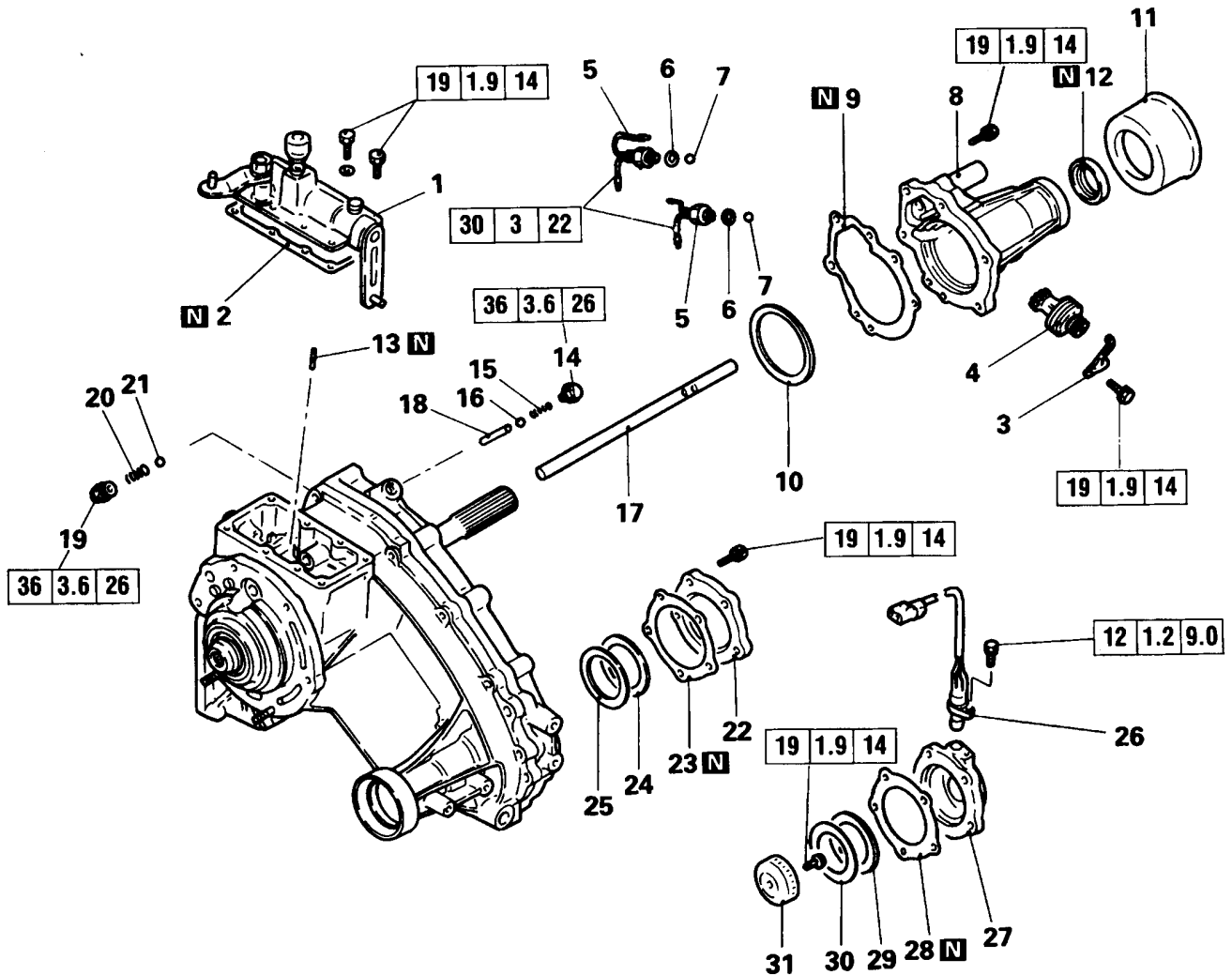

Disassembly steps

- | | | |
|---|--|---|
| <ul style="list-style-type: none"> 1. Control housing assembly (KM147, V5M21-2) 2. Control housing gasket (KM147, V5M21-2) 3. Sleeve clamp ▶N▶ 4. Speedometer gear ▶M▶ 5. 4WD indicator light switch 6. Gasket 7. Steel ball ▶P▶ 8. Rear cover ▶P▶ 9. Rear cover gasket ▶P▶ 10. Spacer 11. Dust seal guard ▶N▶ 12. Oil seal ▶K▶ 13. Spring pin 14. Seal plug 15. Poppet spring 16. Steel ball | <ul style="list-style-type: none"> ▶A▶▶J▶ 17. H-L shift rail 18. Interlock plunger 19. Seal plug 20. Poppet spring 21. Steel ball ▶M▶ 22. Cover ▶M▶ 23. Cover gasket 24. Spacer 25. Wave spring 26. Pulse generator ▶M▶ 27. Cover ▶M▶ 28. Cover gasket 29. Spacer 30. Wave spring 31. Pulse rotor | <p>} Vehicles with pulse generator only</p> |
|---|--|---|

KM145, KM147, V5M21-1, 2, 4

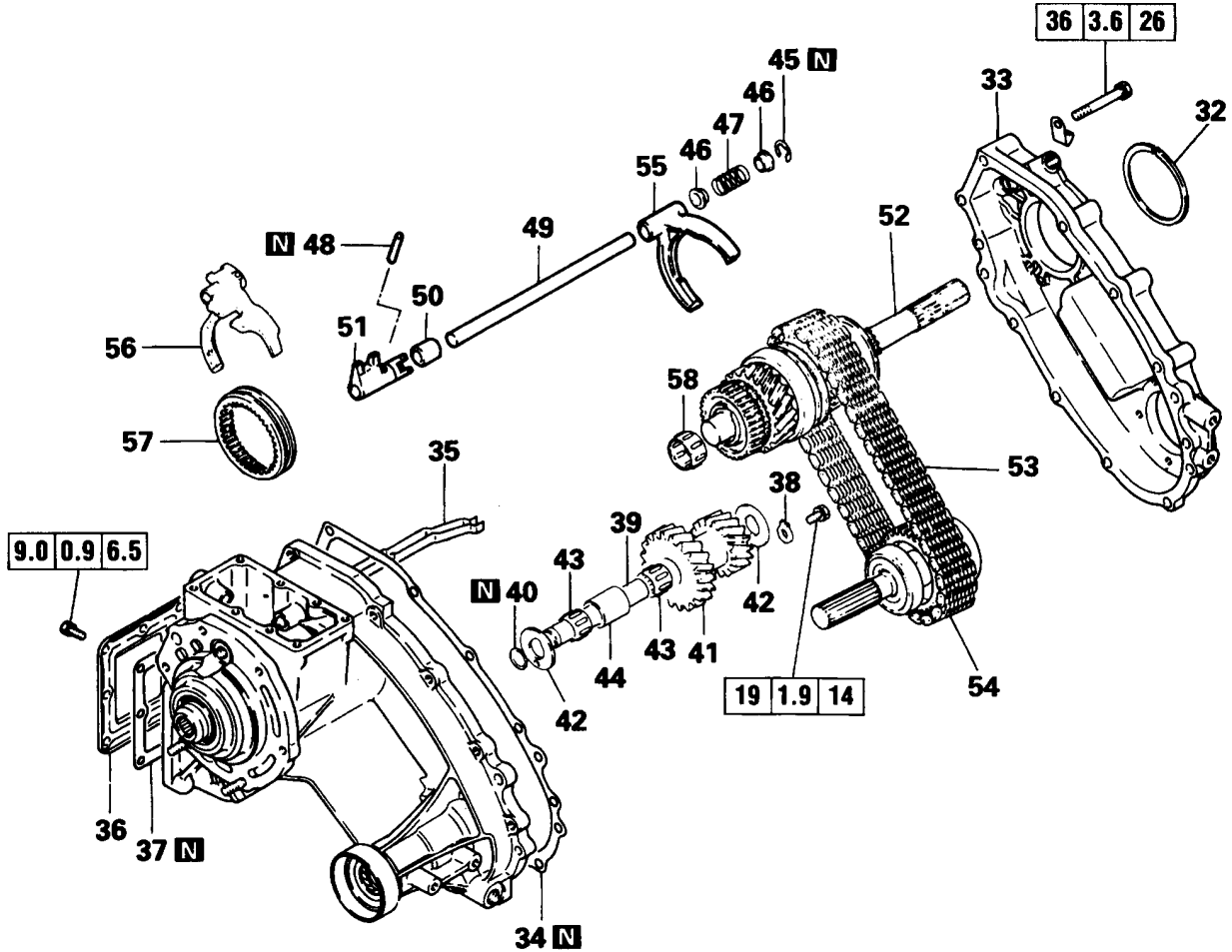

Disassembly steps

- 32. Snap ring
- ▶H▶ 33. Chain cover
- ▶G▶ 34. Chain cover gasket
- 35. Oil guide
- 36. Side cover
- 37. Side cover gasket
- 38. Lock plate
- 39. Counter gear shaft
- 40. O-ring
- 41. Counter gear
- ▶D▶ 42. Thrust washer
- 43. Needle bearing
- 44. Bearing spacer
- 45. Snap ring
- 46. Spring retainer
- 47. Spring
- ▶V▶ 48. Spring pin
- 49. 2-4WD shift rail
- 50. Distance piece
- 51. 2-4WD shift lug
- ◊C◊ ▶F◊ 52. Rear output shaft assembly
- ◊C◊ ▶F◊ 53. Chain
- ◊C◊ ▶F◊ 54. Front output shaft assembly
- 55. 2-4WD shift fork
- 56. H-L shift fork
- 57. H-L clutch sleeve
- 58. Needle bearing

KM145, KM147, V5M21-1, 2, 4

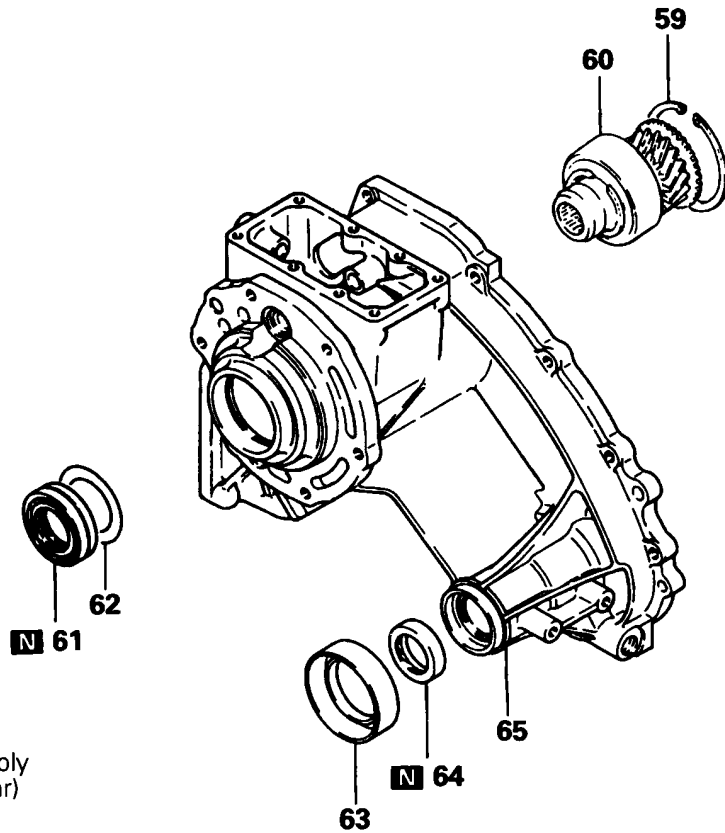

Disassembly steps

- ◆C◆ 59. Snap ring
- 60. Input gear assembly
- ◆B◆ 61. Oil seal (Input gear)
- 62. Baffle plate
- 63. Dust seal guide
- ◆A◆ 64. Oil seal (Front output shaft)
- 65. Transfer case

145084

V5M21-5, 6, 7, 9 (LHD)

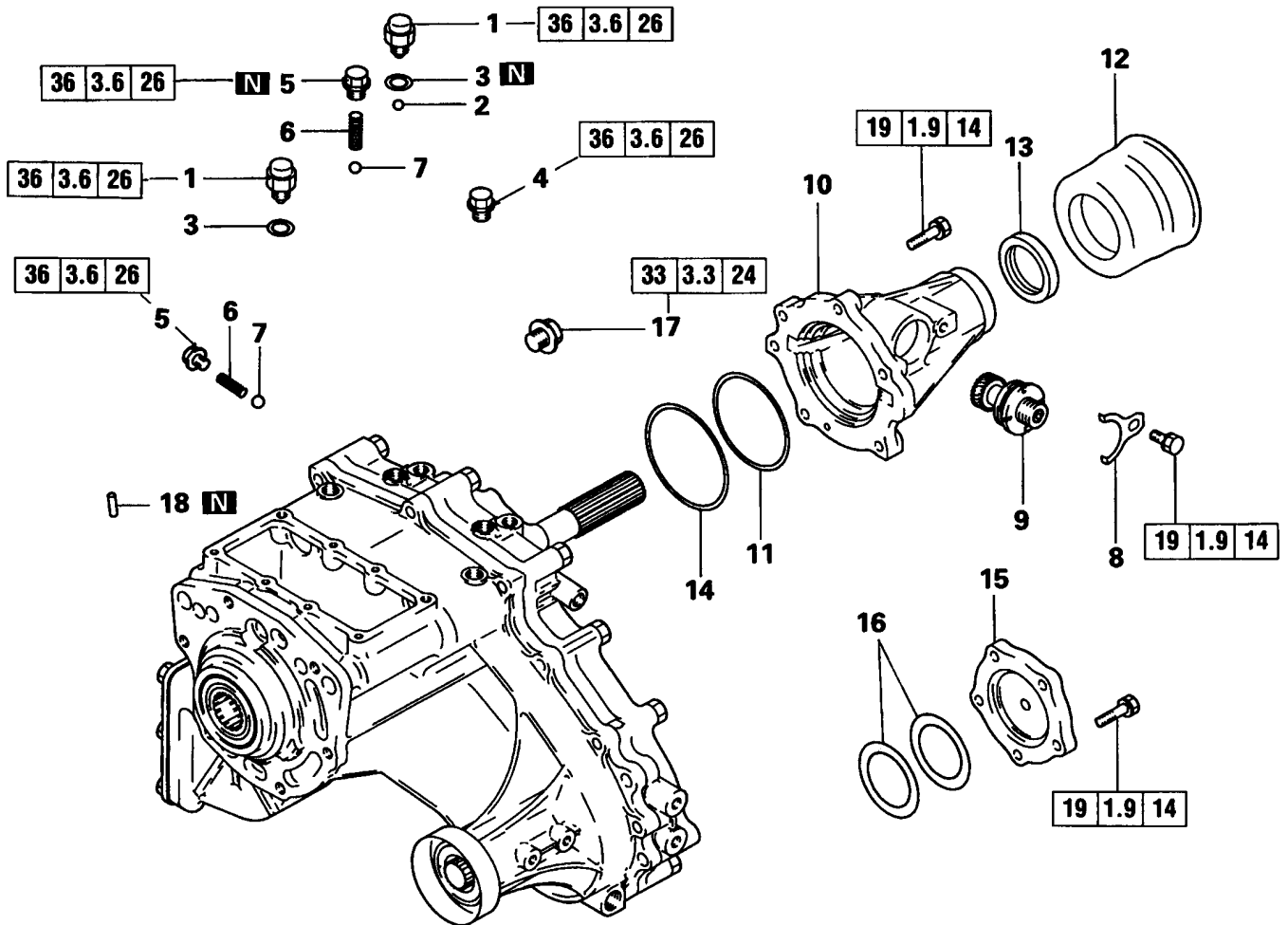

Disassembly steps

- ◆T◆ 1. Detection switch
- 2. Steel ball
- 3. Gasket
- ◆S◆ 4. Plug
- ◆R◆ 5. Poppet plug
- 6. Poppet spring
- 7. Steel ball
- 8. Sleeve clamp
- ◆Q◆ 9. Speedometer gear
- ◆O◆ 10. Rear cover
- ◆O◆ 11. Spacer
- 12. Dust seal guard
- ◆N◆ 13. Oil seal
- 14. Snap ring
- ◆L◆ 15. Cover
- ◆L◆ 16. Wave spring
- 17. H-L shift rail plug
- ◆K◆ 18. Spring pin for H-L shift fork

TRA0273

V5M21-5, 6, 7, 9 (LHD)

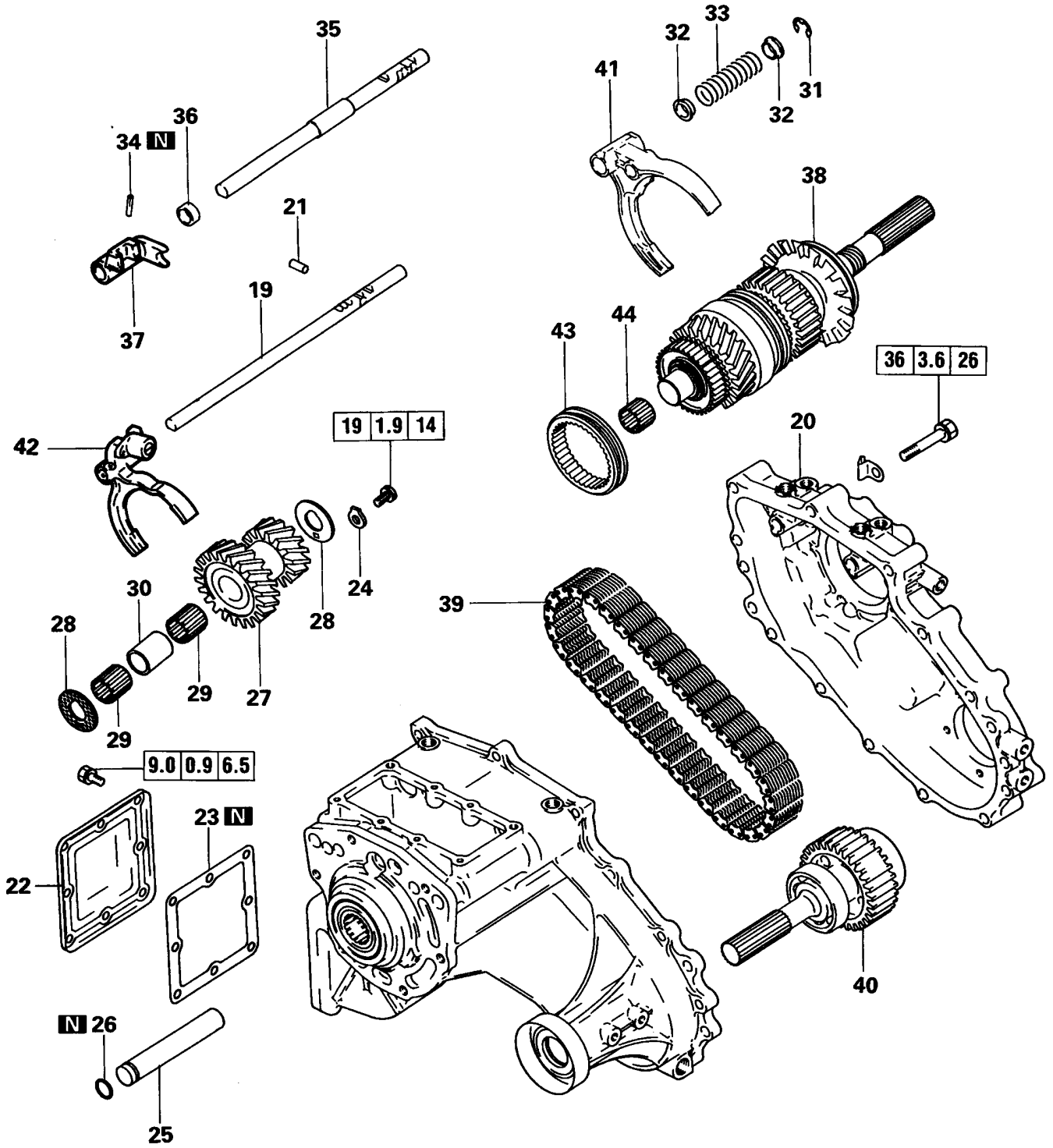

Disassembly steps

- ◊B◊ ◊K◊ 19. H-L shift rail
- ◊B◊ ◊I◊ 20. Chain cover
- ◊I◊ 21. Interlock plunger
- 22. Side cover
- 23. Side cover gasket
- 24. Lock plate
- ◊D◊ ◊E◊ 25. Counter gear shaft
- 26. O-ring
- 27. Counter gear

- ◊D◊ 28. Thrust washer
- 29. Needle bearing
- 30. Bearing spacer
- 31. Snap ring for 2-4WD shift rail
- 32. Spring retainer
- 33. Spring
- ◊V◊ 34. Spring pin for 2-4WD shift lug
- 35. 2-4WD shift rail
- 36. Distance piece

- 37. 2-4WD shift lug
- ◊C◊ ◊F◊ 38. Rear output shaft
- ◊C◊ ◊F◊ 39. Chain
- ◊C◊ ◊F◊ 40. Front output shaft
- 41. 2-4WD shift fork
- 42. H-L shift fork
- 43. H-L clutch sleeve
- 44. Needle bearing

V5M21-5, 6, 7, 9 (LHD)

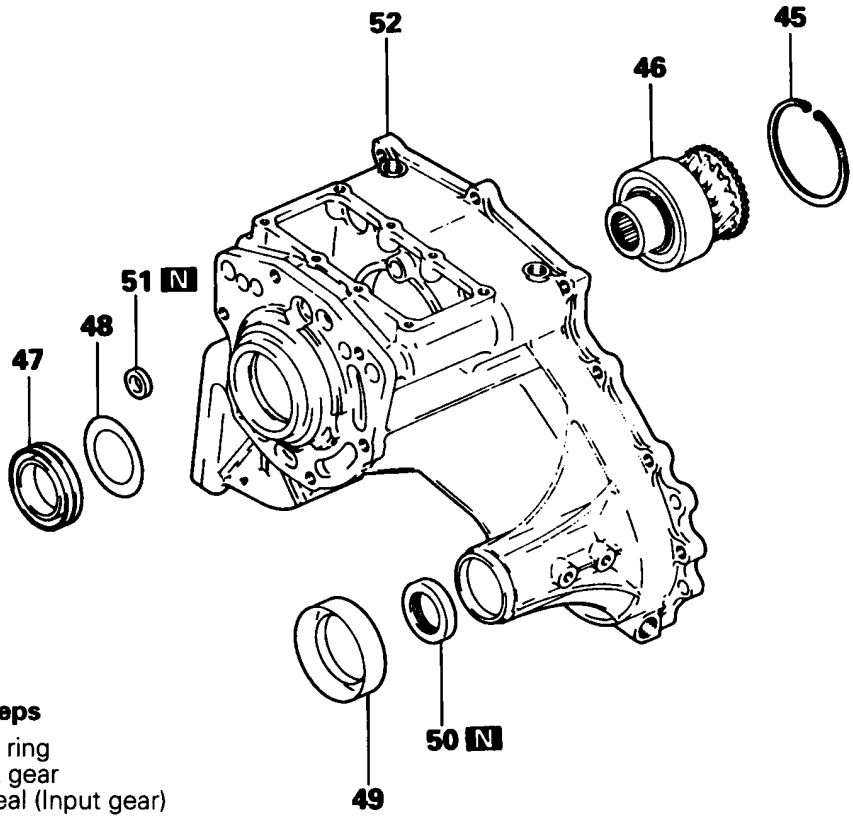

Disassembly steps

- ▶C◀ 45. Snap ring
- 46. Input gear
- ▶B◀ 47. Oil seal (Input gear)
- 48. Baffle plate
- 49. Dust seal guide
- ▶A◀ 50. Oil seal (Front output shaft)
- ▶U◀ 51. Oil seal
- 52. Transfer case

TRM0221

V5M21-5-P, Q (RHD)
 V5M21-6-P, Q, R (RHD)
 V5M21-7 (RHD)
 V5M21-9 (RHD)

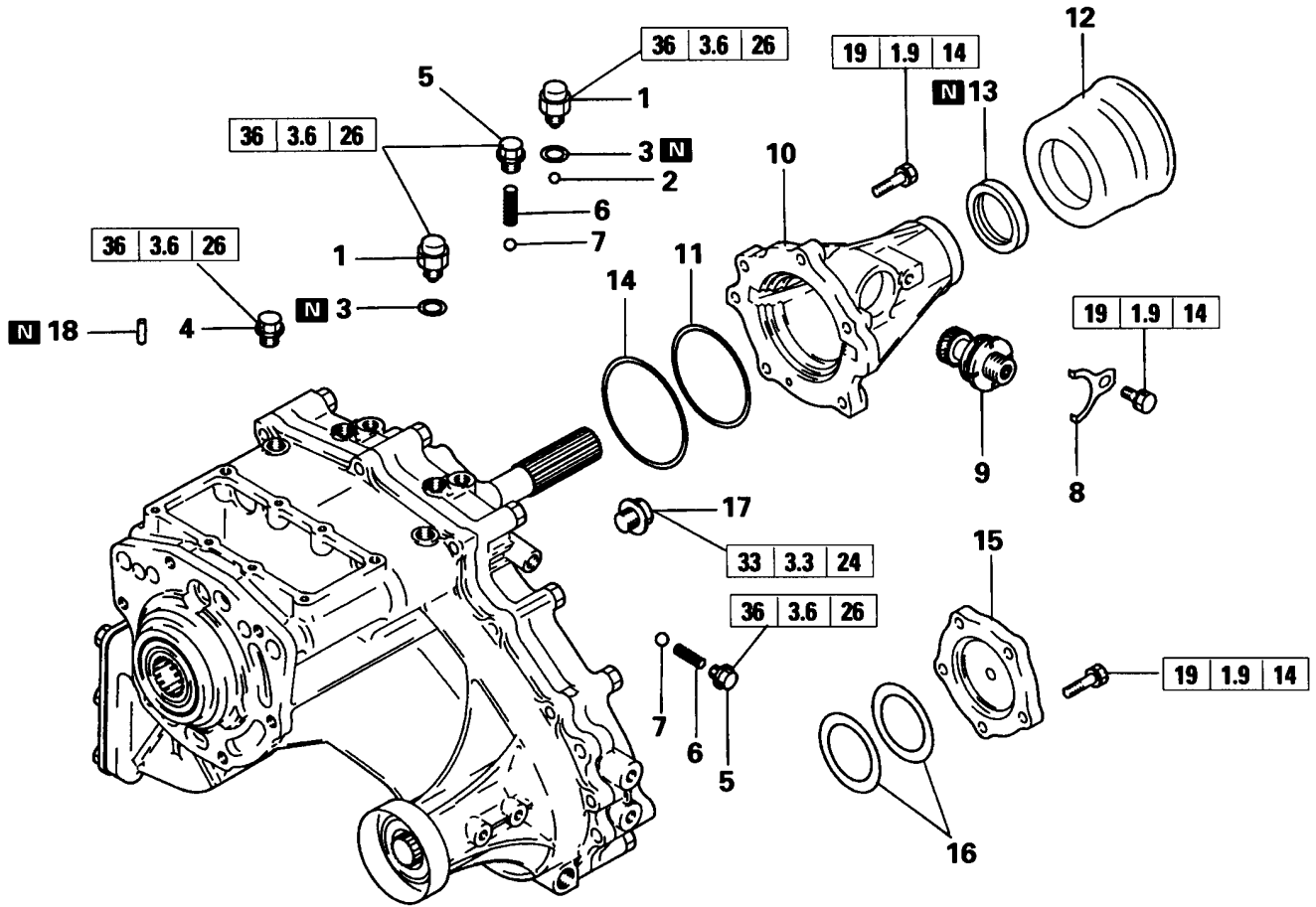

Disassembly steps

- ◆T◆ 1. Detection switch
- 2. Steel ball
- 3. Gasket
- ◆S◆ 4. Plug
- ◆R◆ 5. Poppet plug
- 6. Poppet spring
- 7. Steel ball
- 8. Sleeve clamp
- ◆Q◆ 9. Speedometer gear
- ◆O◆ 10. Rear cover
- ◆O◆ 11. Spacer
- 12. Dust seal guard
- ◆N◆ 13. Oil seal
- 14. Snap ring
- ◆L◆ 15. Cover
- ◆L◆ 16. Wave spring
- 17. H-L shift rail plug
- ◆K◆ 18. Spring pin for H-L shift fork

TRM0257

V5M21-5-P, Q (RHD)
 V5M21-6-P, Q, R (RHD)
 V5M21-7 (RHD)
 V5M21-9 (RHD)

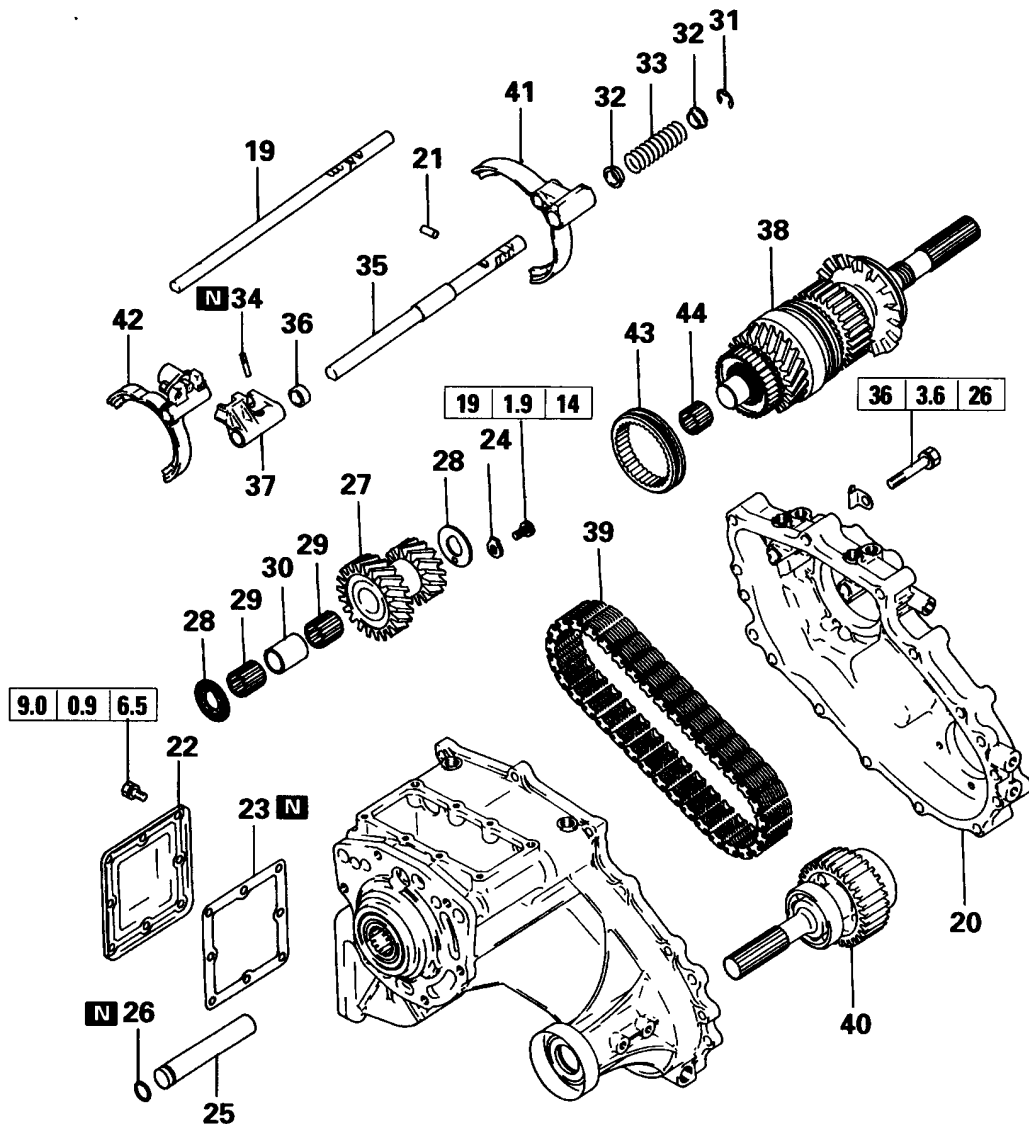

Disassembly steps

- | | | |
|--------------------------------|--|--------------------------------|
| ◀B▶ ▶K▶ 19. H-L shift rail | ▶D▶ 28. Thrust washer | 37. 2-4WD shift lug |
| ◀B▶ ▶I▶ 20. Chain cover | 29. Needle bearing | ◀C▶ ▶F▶ 38. Rear output shaft |
| ▶I▶ 21. Interlock plunger | 30. Bearing spacer | ◀C▶ ▶F▶ 39. Chain |
| 22. Side cover | 31. Snap ring for 2-4WD shift rail | ◀C▶ ▶F▶ 40. Front output shaft |
| 23. Side cover gasket | 32. Spring retainer | 41. 2-4WD shift fork |
| 24. Lock plate | 33. Spring | 42. H-L shift fork |
| ◀D▶ ▶E▶ 25. Counter gear shaft | ▶V▶ 34. Spring pin for 2-4WD shift lug | 43. H-L clutch sleeve |
| 26. O-ring | 35. 2-4WD shift rail | 44. Needle bearing |
| 27. Counter gear | 36. Distance piece | |

TRM0224

V5M21-5-P, Q (RHD)
 V5M21-6-P, Q, R (RHD)
 V5M21-7 (RHD)
 V5M21-9 (RHD)

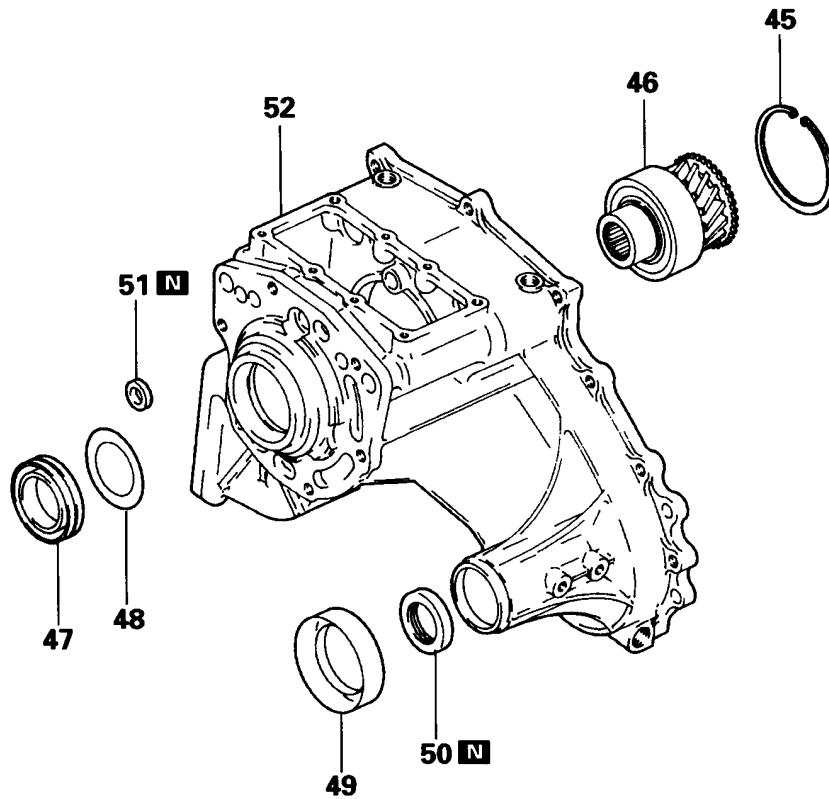

Disassembly steps

- ◆C◆ 45. Snap ring
- 46. Input gear
- ◆B◆ 47. Oil seal (Input gear)
- 48. Baffle plate
- 49. Dust seal guide
- ◆A◆ 50. Oil seal (Front output shaft)
- ◆U◆ 51. Oil seal
- 52. Transfer case

TRM0221

Intentionally blank

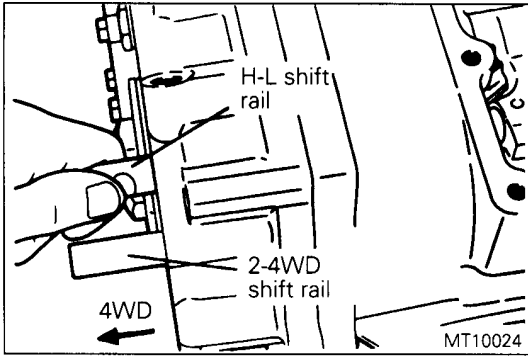

SERVICE POINTS OF DISASSEMBLY

◁A▷ REMOVAL OF H-L SHIFT RAIL

- (1) Shift the 2-4WD shift rail to the 4WD position.

NOTE

If the 2-4WD shift rail is left in the 2WD position, the interlock is actuated, preventing removal of the H-L shift rail.

- (2) Remove the H-L shift rail.

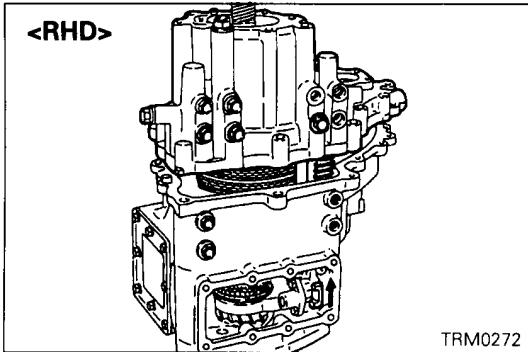

◁B▷ REMOVAL OF H-L SHIFT RAIL / CHAIN COVER

- (1) Lock the H-L shift rail at the high side, using the poppet spring.
- (2) Place the 2-4WD shift rail at the 4WD position.

NOTE

If the 2-4WD shift rail is left at the 2WD position, the chain cover cannot be removed because interlock is actuated.

- (3) Remove the chain cover and remove the H-L shift rail.

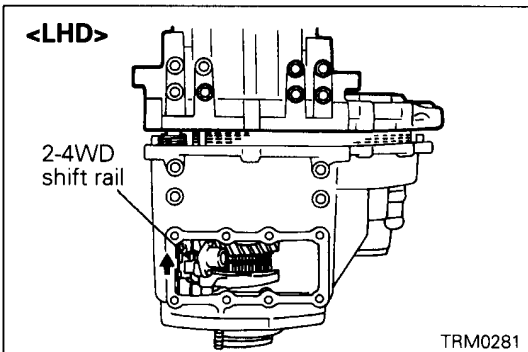

◁C▷ REMOVAL OF REAR OUTPUT SHAFT / CHAIN / FRONT OUTPUT SHAFT

- (1) Remove the front output shaft, rear output shaft and chain together.

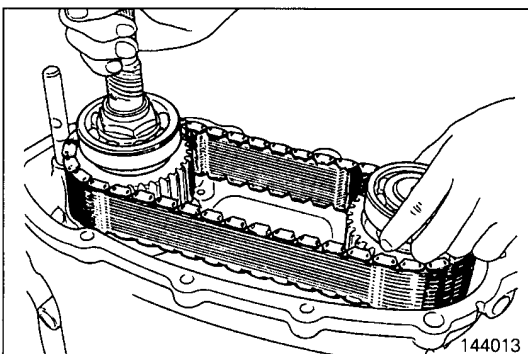

◁D▷ REMOVAL OF COUNTER GEAR SHAFT

- (1) Remove the counter gear shaft toward the transmission case side.

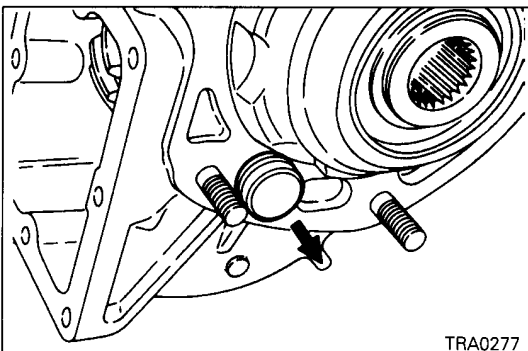

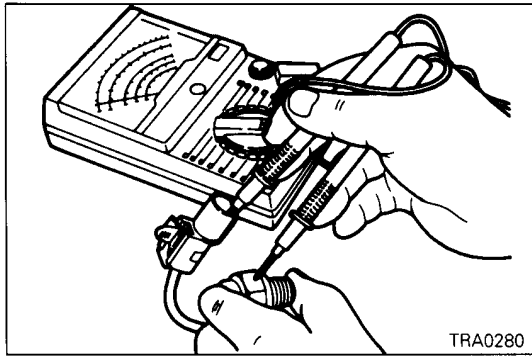

INSPECTION

Detection Switch Inspection

- (1) Check for continuity between the connector terminal and switch body.

Switch state	Continuity
Switch end pressed	No
Switch end released	Exists

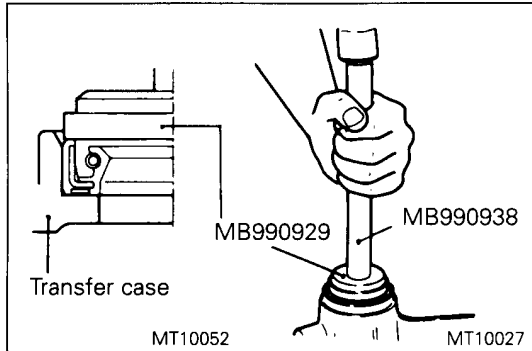

SERVICE POINT OF REASSEMBLY

▶A▶ INSTALLATION OF OIL SEAL (FRONT OUTPUT SHAFT)

- (1) Apply transmission oil to the lip of the oil seal before press-fitting.

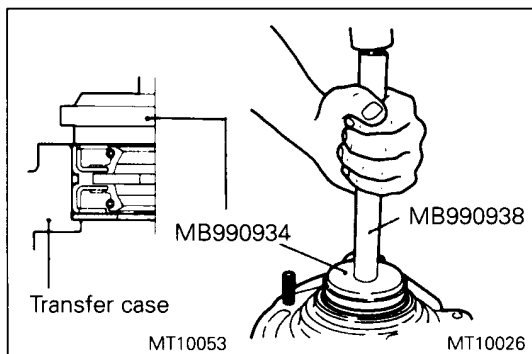

▶B▶ INSTALLATION OF OIL SEAL (INPUT GEAR)

- (1) Apply transmission oil to the lip of the oil seal before press-fitting.

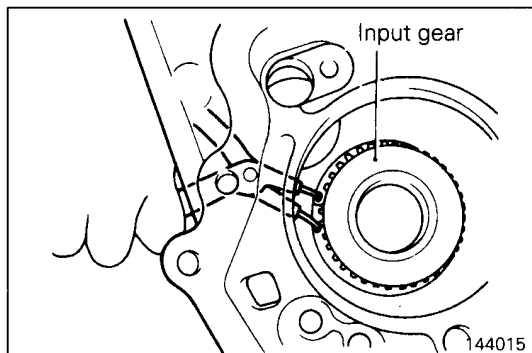

▶C▶ INSTALLATION OF SNAP RING

- (1) Select the thickest snap ring that will fit into the groove and install it.

Standard value: 0 – 0.06 mm (0 – 0.0024 in.)

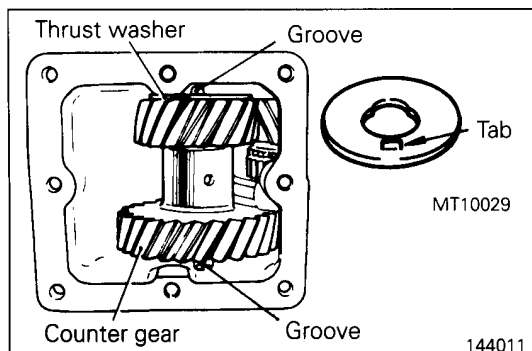

▶D▶ INSTALLATION OF THRUST WASHER

- (1) Install the thrust washer in such a way that the tab will fit into the case groove.

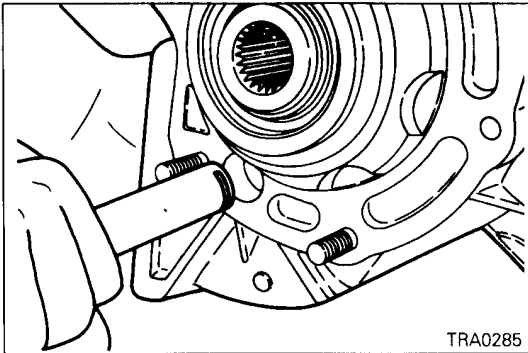

◆E◆ **INSTALLATION OF COUNTER GEAR SHAFT**

- (1) Insert the counter gear shaft from the transmission case side, while taking into account the lock plate groove position.

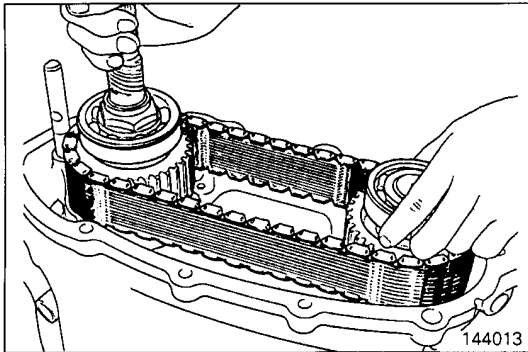

◆F◆ **INSTALLATION OF REAR OUTPUT SHAFT / CHAIN / FRONT OUTPUT SHAFT**

- (1) Engage the chain precisely with the sprocket of the rear output shaft and the front output shaft.
- (2) Install the 2-4WD shift fork on the 2-4WD clutch sleeve. While passing them along the 2-4WD shift rail, install the rear and front output shaft and chain.

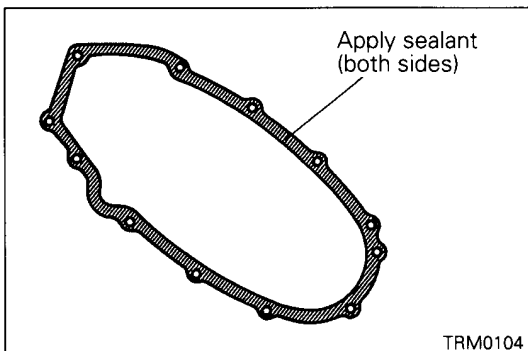

◆G◆ **APPLICATION OF SEALANT TO CHAIN COVER GASKET**

Specified sealant:

Mitsubishi genuine sealant Part No. 997740 or equivalent

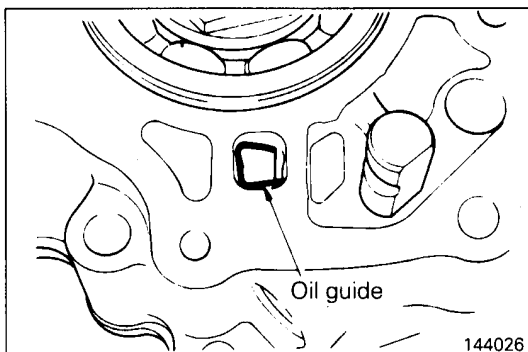

◆H◆ **INSTALLATION OF CHAIN COVER**

- (1) Install the chain cover so that the end of the oil guide may enter the hole shown in the illustration.

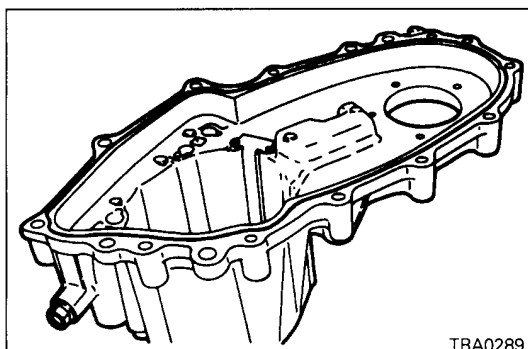

◆I◆ **INSTALLATION OF CHAIN COVER / INTERLOCK PLUNGER**

- (1) Insert the interlock plunger into a position where it does not interfere with the 2-4WD shift rail.
- (2) Apply a sealant to the chain cover before installing it.

Specified sealant:

Mitsubishi genuine sealant Part No. 997740 or equivalent

Caution

- Squeeze the sealant out evenly to apply it in an unbroken, non-excessive quantity.

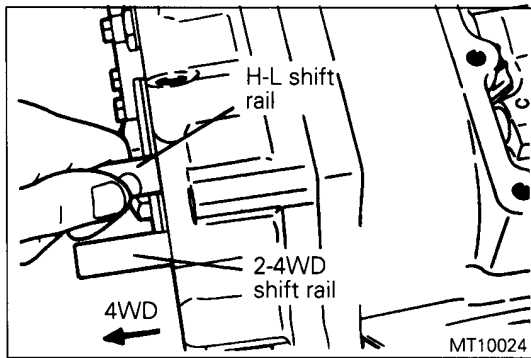

⇨⇩ INSTALLATION OF H-L SHIFT RAIL

- (1) Shift the 2-4WD shift rail to the 4WD position.
- (2) Insert the H-L shift rail from the case and pass the rail through the shift fork.

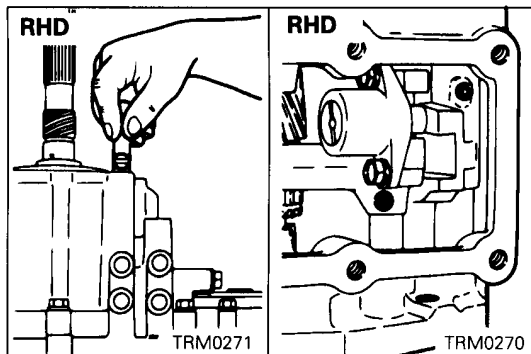

⇨⇩ INSTALLATION OF H-L SHIFT RAIL / SPRING PIN FOR H-L SHIFT FORK

- (1) Insert the H-L shift rail from the H-L shift rail plug hole, while taking into account its direction.
- (2) Line up the shift rail and shift fork spring pin hole and install the spring pin so that the slit of the spring pin will face the axial center of the shift rail.

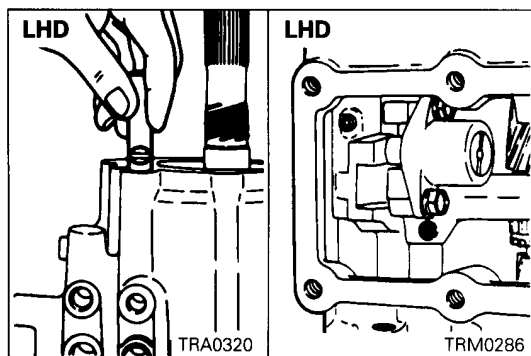

⇨⇩ INSTALLATION OF COVER / WAVE SPRING (SPACER)

- (1) Measure projection "A" of the front output shaft rear bearing and depth "B" of the cover.
If B is more than 2 mm (0.08 in.) greater than A, add a spacer between the wave spring and cover.
If the difference is 2 mm (0.08 in.) or less, using only the wave spring is enough.
- (2) Apply a sealant to the cover and then mount the cover.

Specified sealant:

Mitsubishi genuine sealant Part No. 997740 or equivalent

Caution

- Squeeze out the sealant evenly to apply it in an unbroken, non-excessive quantity.

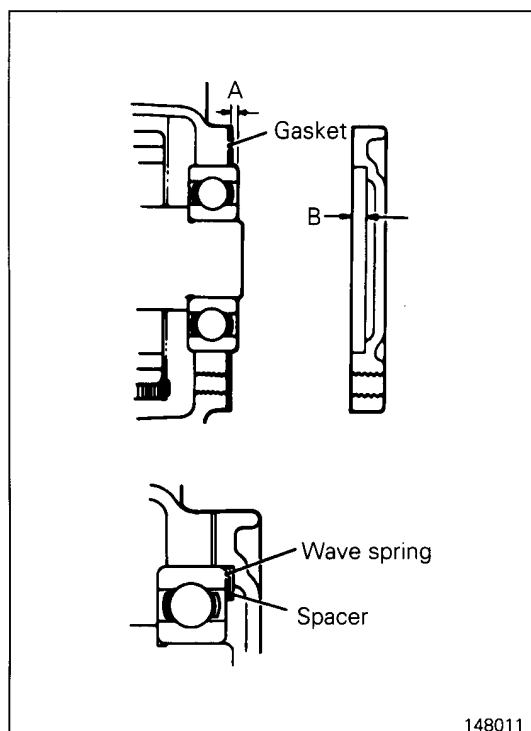

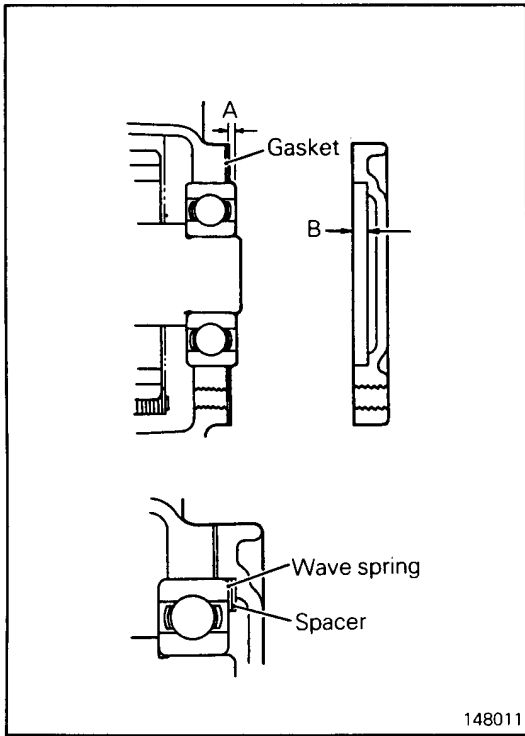

148011

◆M◆ INSTALLATION OF COVER GASKET / COVER

(1) Measure the projection (A) of the rear bearing from the end of the front output shaft and the depth (B) of indentation in the cover.

If the clearance (a difference between A and B) exceeds 2 mm (0.08 in.), insert a spacer between the cover and the wave spring. If the clearance is 2 mm (0.08 in.) or less, use the wave spring alone.

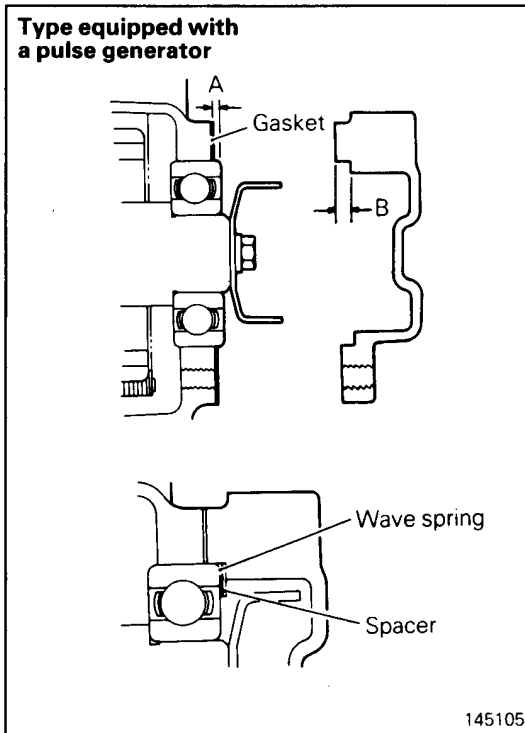

145105

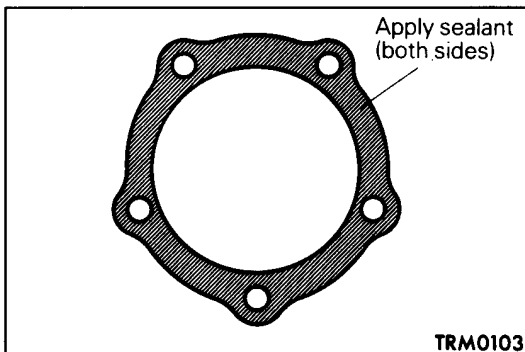

TRM0103

(2) Apply specified sealant to both sides of the cover gasket.

Specified sealant:

Mitsubishi genuine sealant Part No. 997740 or equivalent

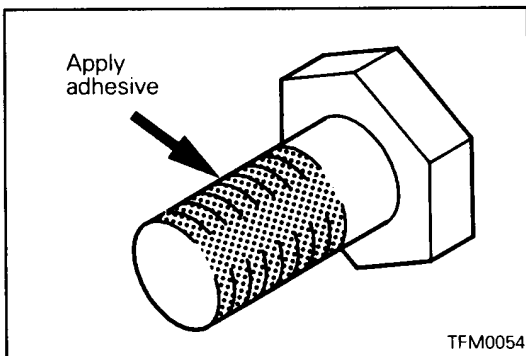

- (3) Install the cover.
- (4) Apply the specified adhesive to the threaded part of the cover installation bolt.

Specified adhesive:

3M STUD Locking No. 4170 or equivalent

- (5) Tighten the cover installation bolt at the specified torque.

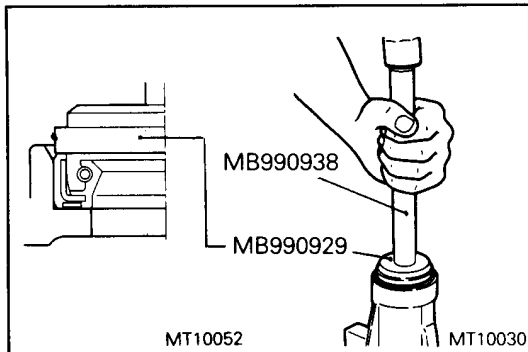

◆N◆ INSTALLATION OF OIL SEAL

- (1) Apply transmission oil to the lip of the oil seal before press-fitting.

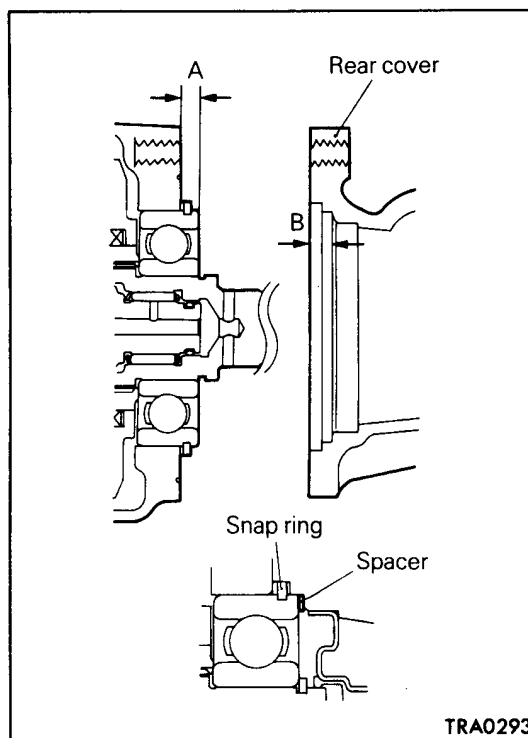

◆O◆ INSTALLATION OF SPACER / REAR COVER

- (1) Measure projection "A" of the rear output shaft bearing and depth "B" of the second stage of the rear cover. Subtract A from B and let the answer be C. Subtract the thickness of the spacer from C, and select a snap ring so that the subtracted value will be the standard value shown below.

Standard value: 0 – 0.1 mm (0 – 0.004 in.)

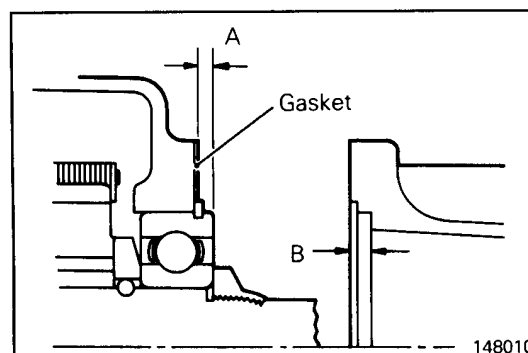

◆P◆ INSTALLATION OF SPACER / REAR COVER GASKET / REAR COVER

- (1) Measure the amount of protrusion of the rear output shaft rear bearing "A" and the amount of inset in the cover "B". Select a spacer which adjusts the end play to the standard value.

Standard value: 0 – 0.1 mm (0 – 0.004 in.)

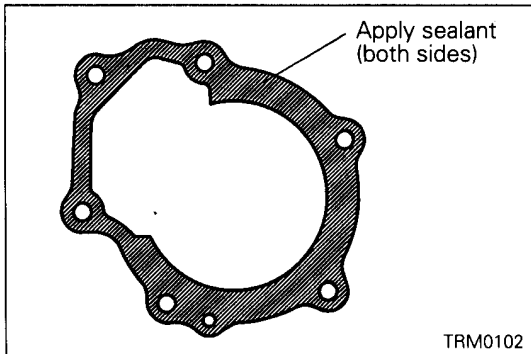

- (2) Apply sealant to both sides of the rear cover gasket.

Specified sealant:

Mitsubishi genuine sealant Part No. 997740 or equivalent

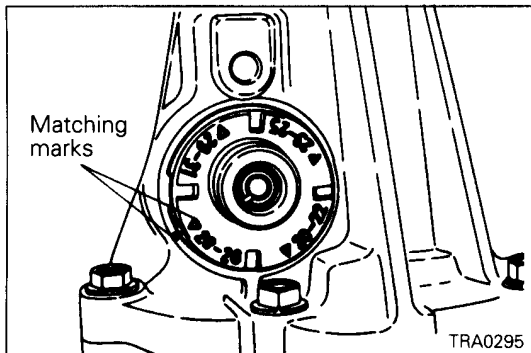

◆Q◆ INSTALLATION OF SPEEDOMETER GEAR

- (1) Match the matching marks to the number of teeth.

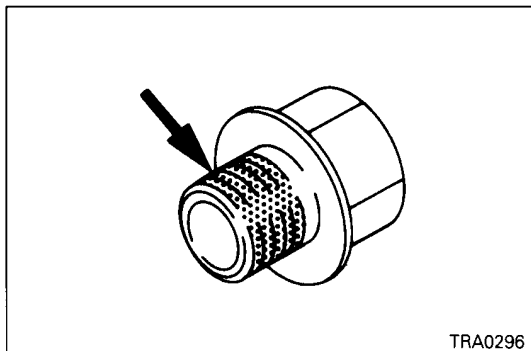

◆R◆ APPLICATION OF SEALANT TO POPPET PLUG

- (1) Apply sealant to the poppet plug before installation.

Specified sealant:

3M ATD Part No. 8660 or equivalent

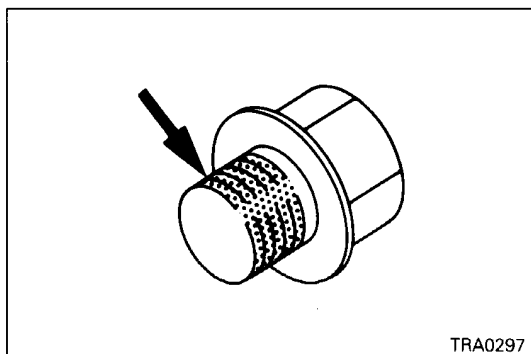

◆S◆ APPLICATION OF SEALANT TO PLUG

- (1) The plug is a precoated one. When it is to be reused, apply sealant to the plug beforehand.

Specified sealant:

3M ATD Part No. 8660 or equivalent

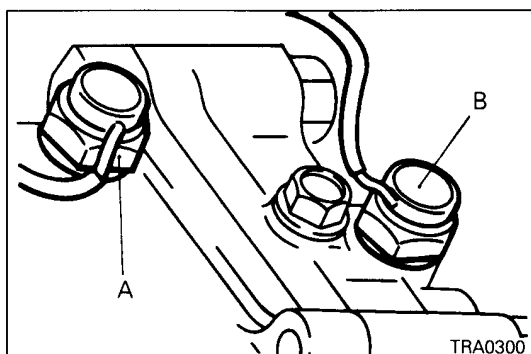

◆T◆ INSTALLATION OF DETECTION SWITCH

- (1) Mount detection switches in the right position, while being careful not to confuse anything.

LHD

A: Ball built in

B: Ball separate

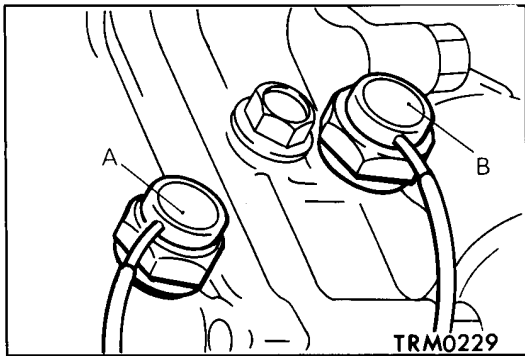

RHD
A: Ball built in
B: Ball separate

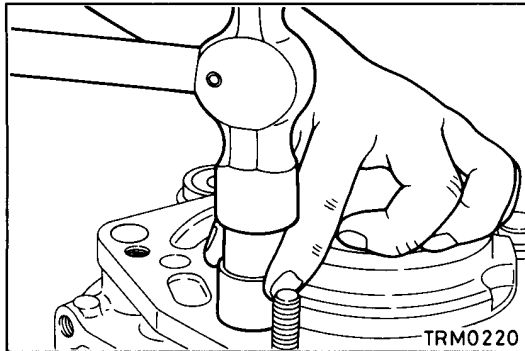

◆U◆ INSTALLATION OF OIL SEAL

- (1) Using a socket wrench, install the oil seal. After installation, pack the lips with grease.

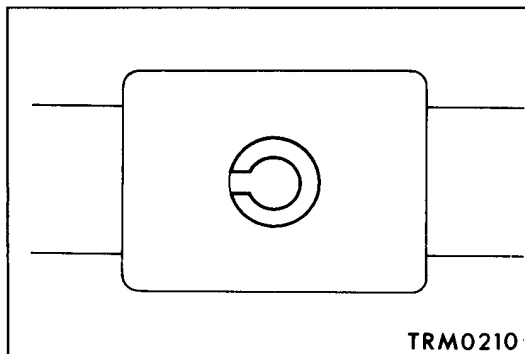

◆V◆ INSTALLATION OF SPRING PIN

11a. TRANSFER <V5M21-A>

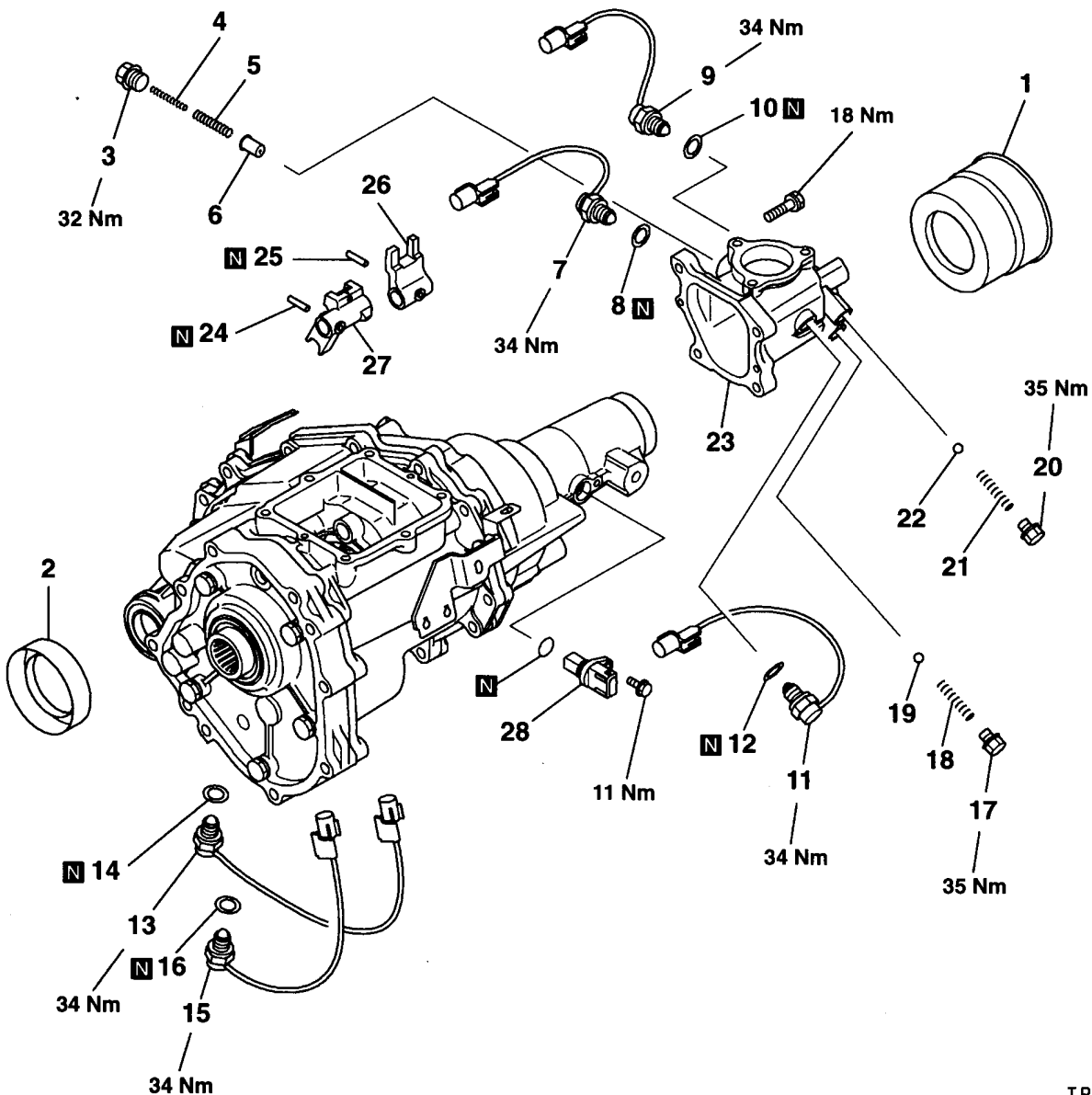

TRM1277

Disassembly steps

- | | | | | | |
|-----|------------------------------------|-----|------------------------------|--|--|
| | 1. Dust seal guard | | | | |
| | 2. Dust seal guard | | | | |
| ▶c◀ | 3. Select plunger seal plug | ▶Z◀ | 15. Lock detector switch | | |
| | 4. Return spring | ▶Y◀ | 16. Gasket | | |
| | 5. Return spring | ▶X◀ | 17. Poppet seal bolt | | |
| | 6. Select plunger | | 18. Spring | | |
| ▶b◀ | 7. Hi-Lo detector switch | | 19. Steel ball | | |
| | 8. Gasket | ▶Y◀ | 20. Poppet seal bolt | | |
| ▶b◀ | 9. 4WD operation detector switch | ▶X◀ | 21. Spring | | |
| | 10. Gasket | | 22. Steel ball | | |
| ▶a◀ | 11. Lock operation detector switch | ▶W◀ | 23. Transfer control housing | | |
| | 12. Gasket | ▶V◀ | 24. Spring pin | | |
| ▶Z◀ | 13. 4WD detector switch | ▶U◀ | 25. Spring pin | | |
| | 14. Gasket | ▶T◀ | 26. Hi-Lo shift lug | | |
| | | | 27. 2WD/4WD shift lug | | |
| | | | 28. Vehicle speed sensor | | |

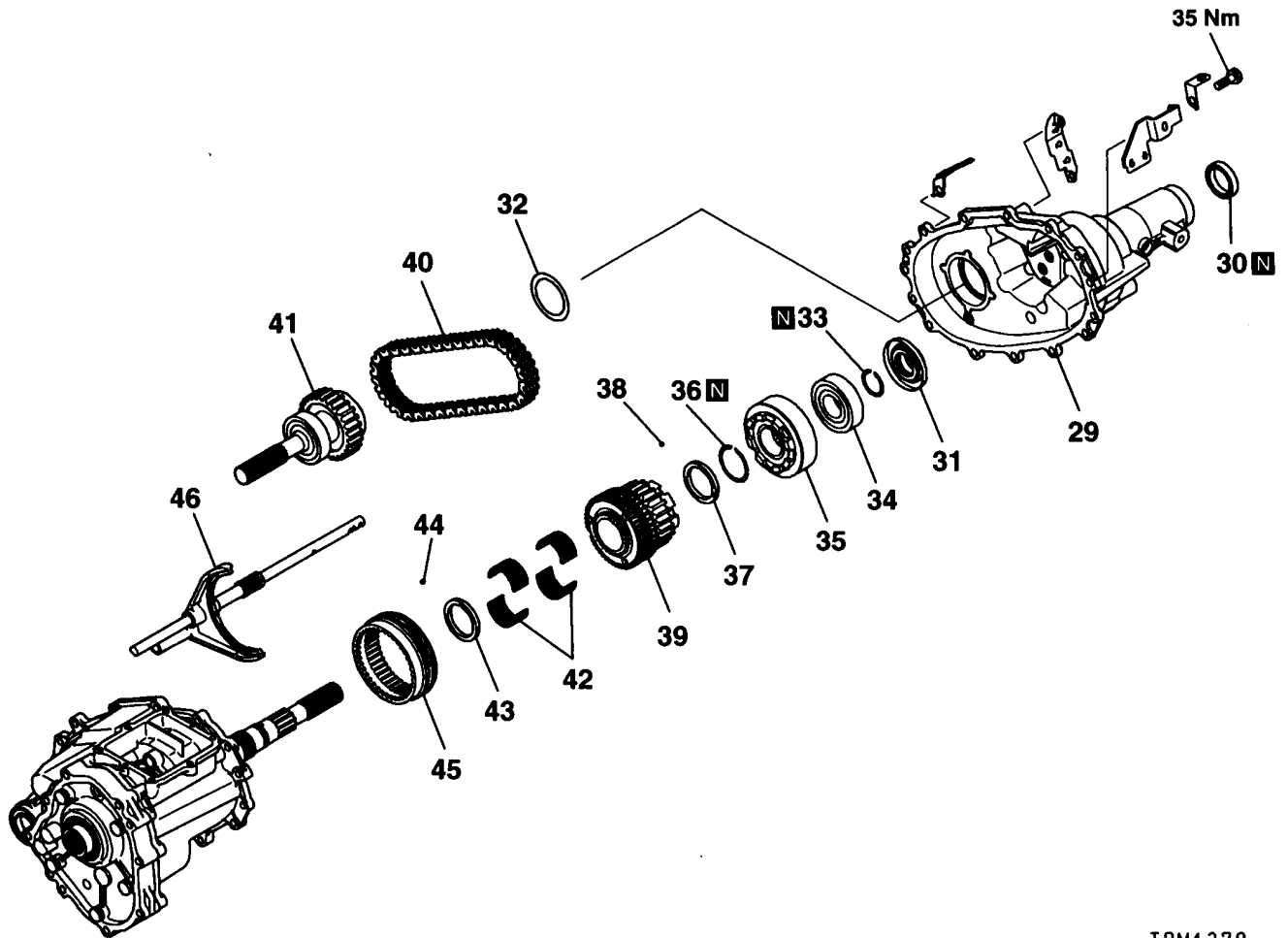

TRM1278

Disassembly steps

- ◀B▶ ▶S▶ 29. Transfer rear cover
- ▶R▶ 30. Oil seal
- ▶Q▶ 31. Oil guide
- ▶P▶ 32. Wave spring
- ▶O▶ 33. Snap ring
- ◀C▶ ▶N▶ 34. Ball bearing
- ▶M▶ 35. Viscous coupling
- ▶L▶ 36. Snap ring
- ▶L▶ 37. Spacer

- ◀D▶ ▶K▶ 38. Steel ball
- ◀D▶ ▶K▶ 39. 2WD/4WD synchronizer
- ◀D▶ ▶K▶ 40. Chain
- ▶J▶ 41. Front output shaft
- ▶I▶ 42. Needle bearings
- ▶I▶ 43. Spacer
- ▶I▶ 44. Steel ball
- ▶I▶ 45. Synchronizer sleeve
- ▶I▶ 46. 2WD/4WD shift fork and rail

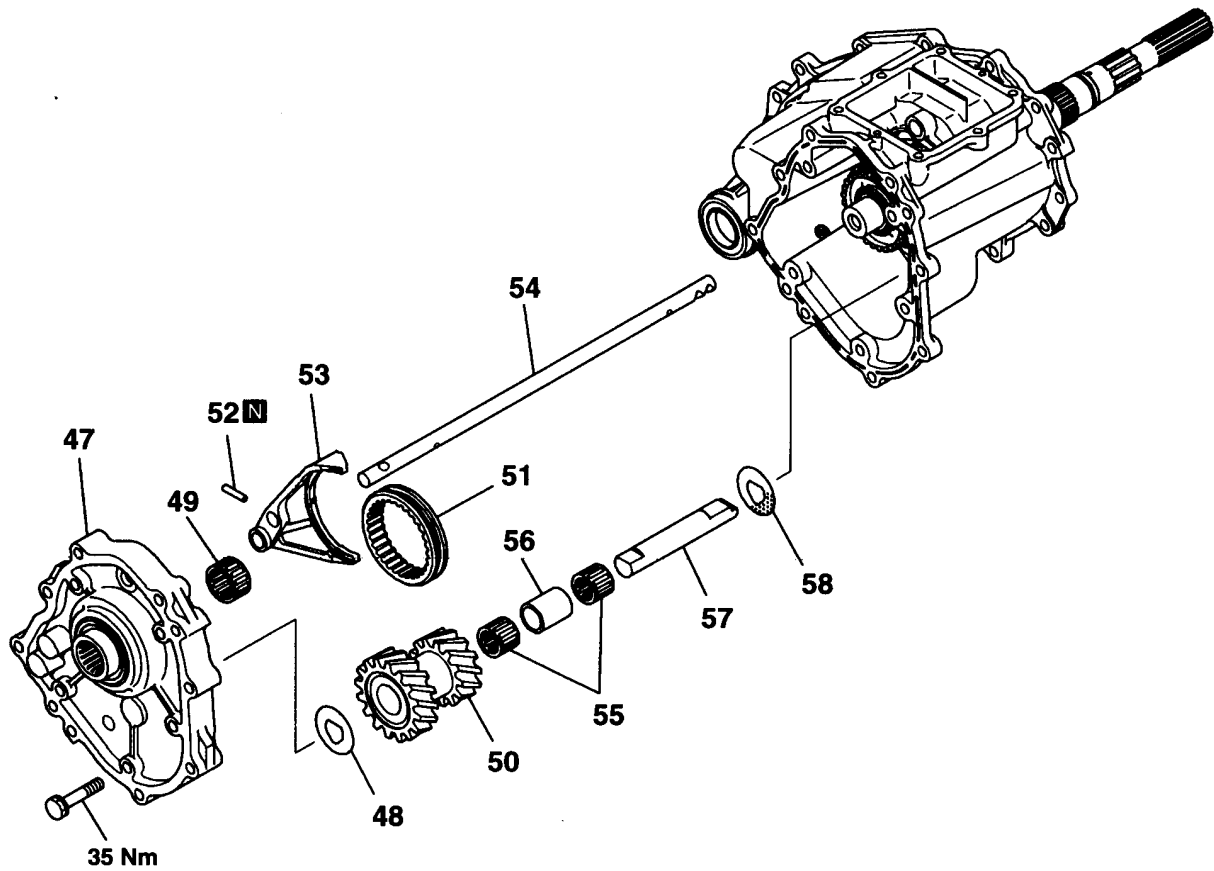

TRM1279

Disassembly steps

- ◀E▶ ▶H▶ 47. Transfer case plate
- ▶G▶ 48. Thrust washer
- ▶G▶ 49. Needle bearing
- ▶G▶ 50. Counter gear
- ▶F▶ 51. Hi-Lo clutch sleeve
- ▶E▶ 52. Spring pin

- ▶E▶ 53. Hi-Lo shift fork
- ▶E▶ 54. Hi-Lo shift rail
- ▶E▶ 55. Needle bearings
- ▶E▶ 56. Bearing spacer
- ▶D▶ 57. Counter gear shaft
- ▶D▶ 58. Thrust washer

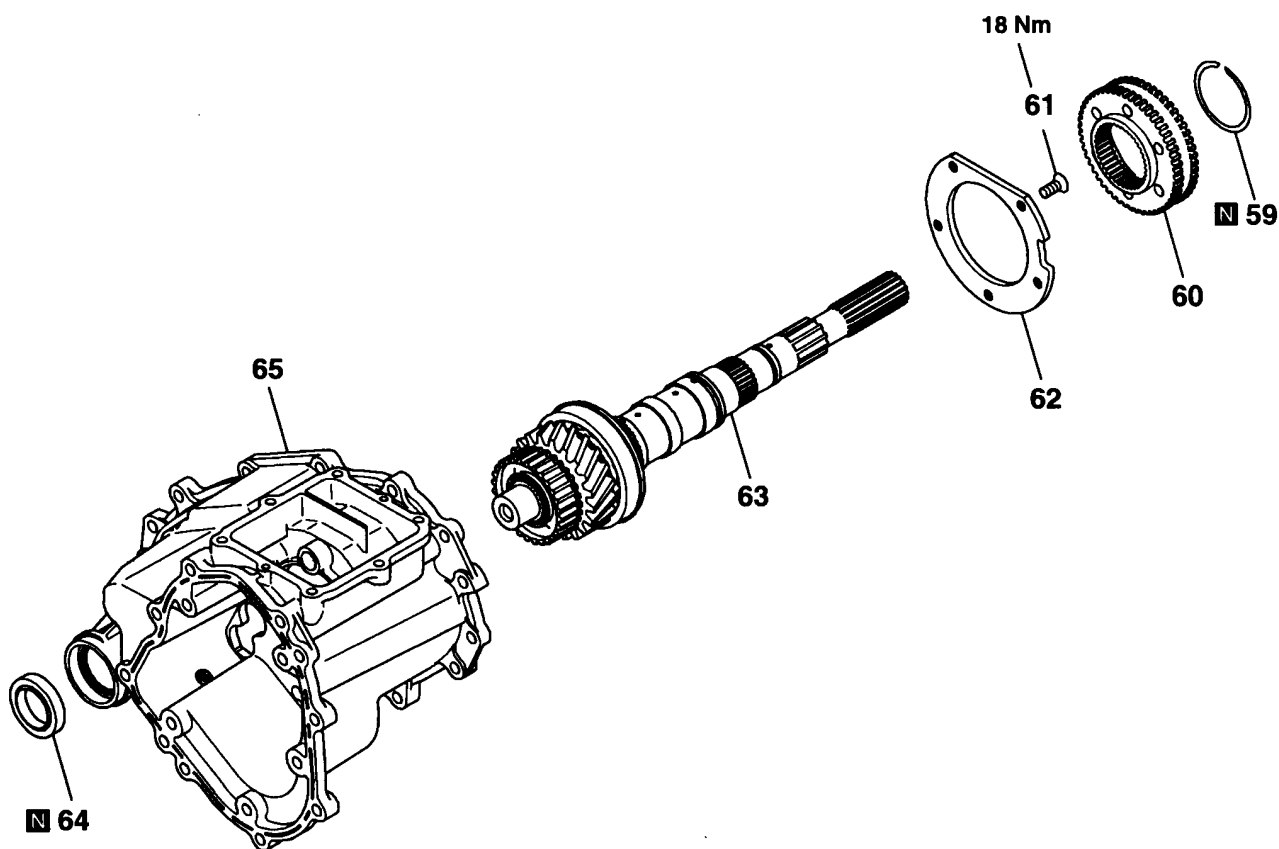

TRM1280

Disassembly steps

- ▶C◀ 59. Snap ring
- 60. Differential lock hub
- ▶B◀ 61. Center bearing retainer seal bolt
- 62. Center bearing retainer
- 63. Rear output shaft
- ▶A◀ 64. Oil seal
- 65. Transfer case

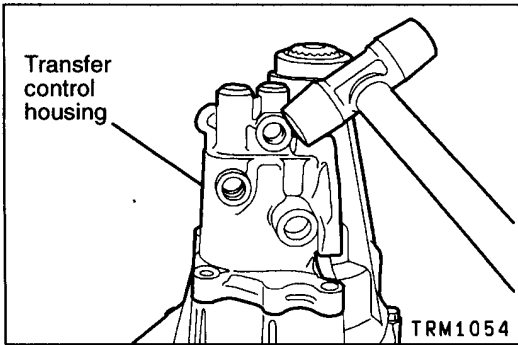

DISASSEMBLY SERVICE POINTS

◀A▶ TRANSFER CONTROL HOUSING REMOVAL

- (1) Remove the transfer control housing by tapping lightly with a plastic hammer or some other similar tool.

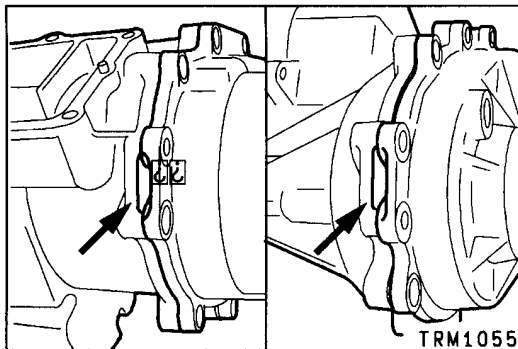

◀B▶ TRANSFER REAR COVER REMOVAL

- (1) Tap the transfer rear cover at the two locations indicated in the illustration to remove it.

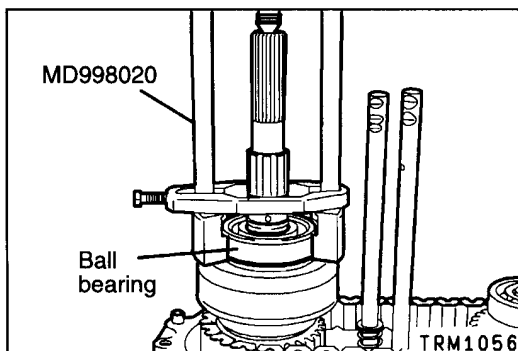

◀C▶ BALL BEARING REMOVAL

- (1) Remove the ball bearing using the indicated special tool.

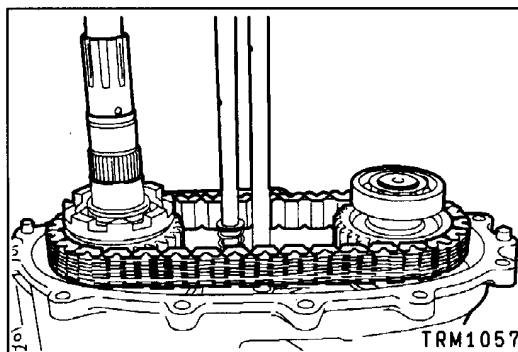

◀D▶ 2WD/4WD SYNCHRONIZER / CHAIN / FRONT OUTPUT SHAFT REMOVAL

- (1) Remove the 2WD/4WD synchronizer, chain, and front output shaft at the same time.

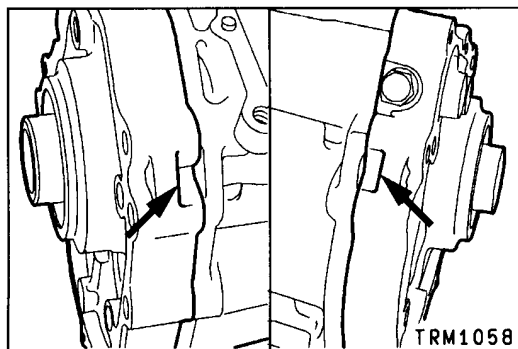

◀E▶ TRANSFER CASE PLATE REMOVAL

- (1) Tap the transfer case plate at the two locations indicated in the illustration to remove it.

Caution

- The counter gear and ancillary parts will be freed together; take care to avoid letting them fall.

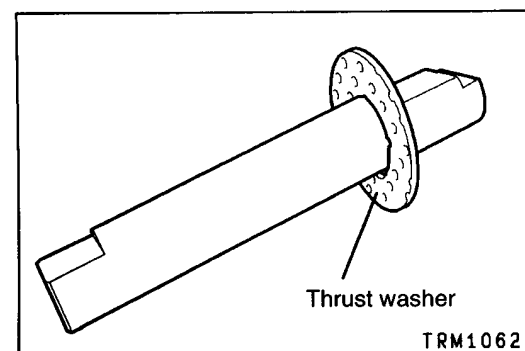
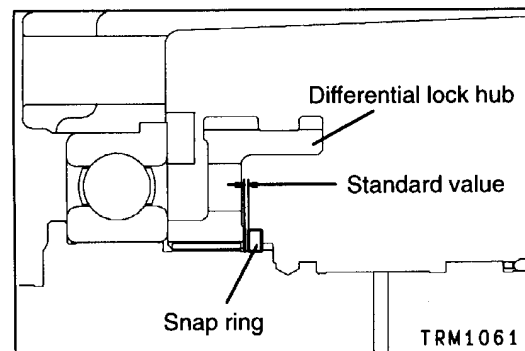
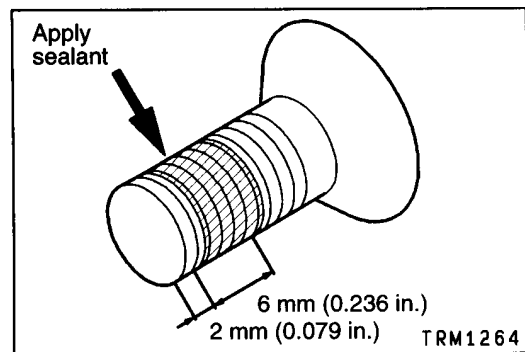
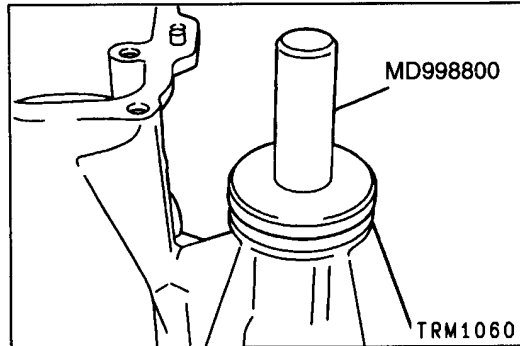
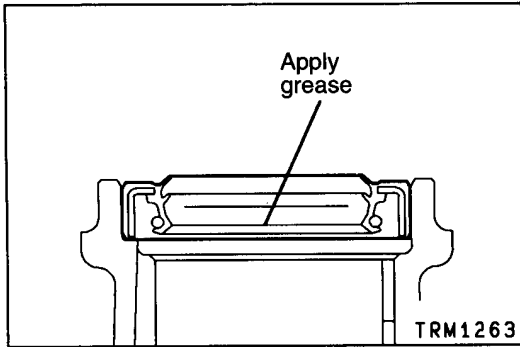

REASSEMBLY SERVICE POINTS

▶A◀ OIL SEAL INSTALLATION

- (1) Apply grease to the lip of the oil seal; then assemble the seal using the indicated special tool.

Specified grease:

Mitsubishi genuine grease Part No. MD0101011 or equivalent

▶B◀ CENTER BEARING RETAINER SEAL BOLT INSTALLATION (when reused)

- (1) Apply sealant to the threaded area of the bolt indicated in the illustration; following this, tighten to the specified torque.

Specified sealant:

3M STUD Locking No. 4170 or equivalent

NOTE

Ensure that any old sealant still adhering to the seal bolt is fully removed.

▶C◀ SNAP RING INSTALLATION

- (1) Select and install a suitable snap ring to ensure that the end play of the differential lock hub is at the standard value.

Standard value: 0 – 0.08 mm (0 – 0.0031 in.)

▶D◀ THRUST WASHER / COUNTER GEAR SHAFT INSTALLATION

- (1) Install the thrust washer on the counter gear shaft as shown with the oil grooves in the washer oriented in the indicated direction.

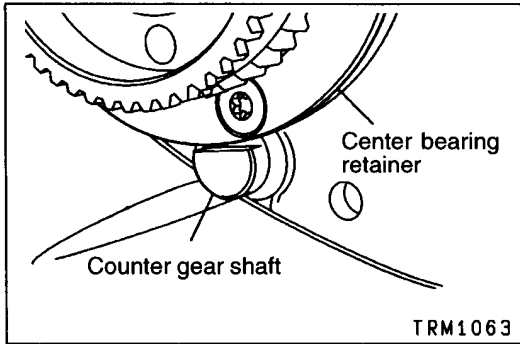

- (2) Install the counter gear shaft with its notch toward the center bearing retainer so that it can be prevented from turning by the retainer.

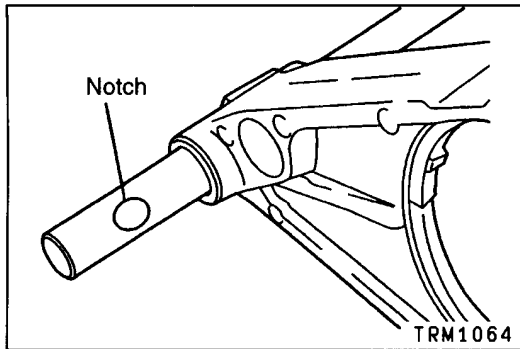

▶E◀ HI-LO SHIFT RAIL / HI-LO SHIFT FORK / SPRING PIN INSTALLATION

- (1) Assemble the Hi-Lo shift rail and Hi-Lo shift fork in such a way that they are oriented as shown.

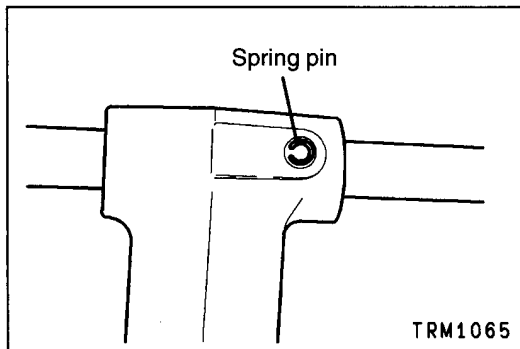

- (2) Drive in the spring pin with its slit oriented as shown.

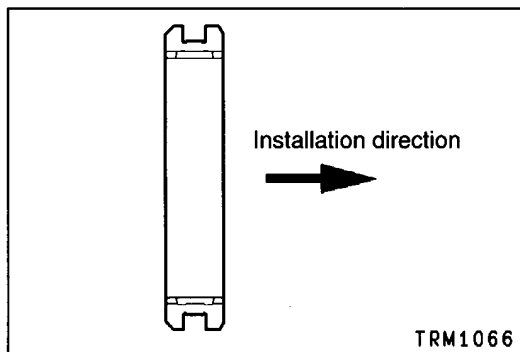

▶F◀ HI-LO CLUTCH SLEEVE INSTALLATION

- (1) Install the Hi-Lo clutch sleeve in the indicated orientation.

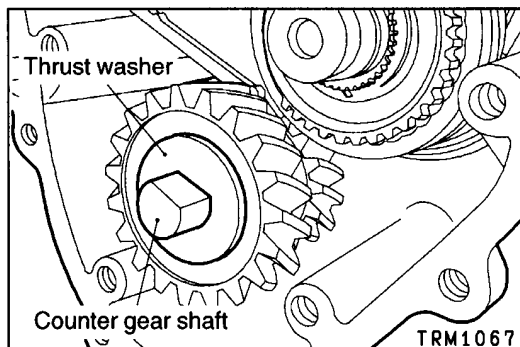

▶G◀ THRUST WASHER INSTALLATION

- (1) Align the flat of the thrust washer with that of the counter gear shaft, then install the thrust washer with its oil-grooved surface facing the counter gear.

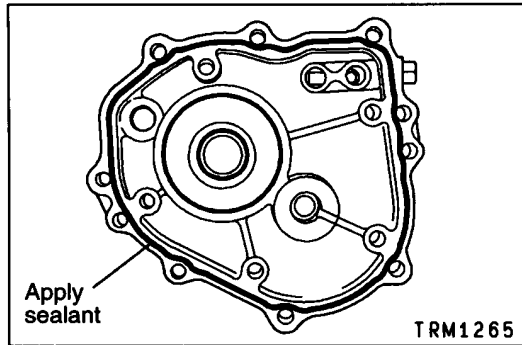
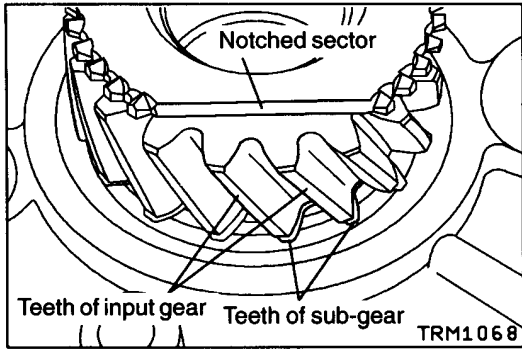

▶H◀ TRANSFER CASE PLATE INSTALLATION

- (1) Align the teeth of the input gear which are located at the notched section with those of the sub-gear.

- (2) Apply sealant to the illustrated position of the transfer case plate.

Specified sealant:

Mitsubishi genuine sealant Part No. MD997740 or equivalent

Caution

- Squeeze the sealant out evenly to ensure that the bead is not broken and that over-application is not performed.

- (3) Direct the notch in the input gear toward the counter gear, then install the transfer case plate while using care that the teeth alignment attained in step (1) may be maintained.

NOTE

The transfer case plate must be installed smoothly without hitching.

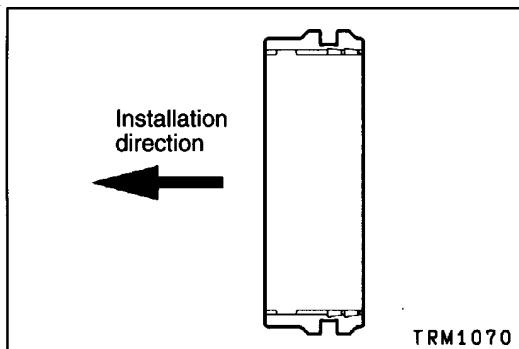

▶I◀ 2WD/4WD SHIFT FORK, SHIFT RAIL / SYNCHRONIZER SLEEVE INSTALLATION

- (1) Install the synchronizer sleeve in the indicated direction.

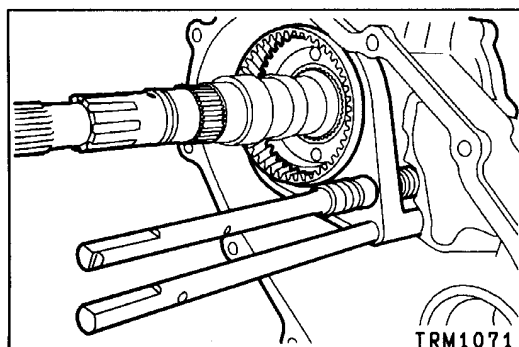

- (2) Shift the Hi-Lo shift rail in the illustrated position, then assemble the synchronizer sleeve, the 2WD/4WD shift fork, and the shift rail.

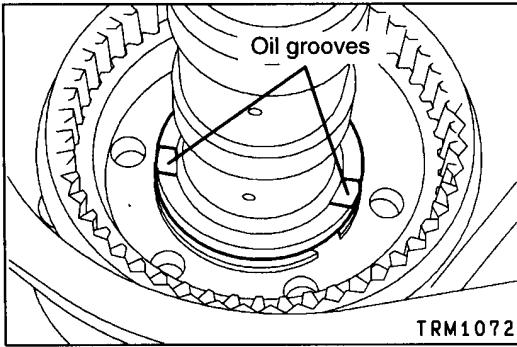

►J◄ SPACER INSTALLATION

- (1) Install the spacer with its oil grooves oriented as indicated.

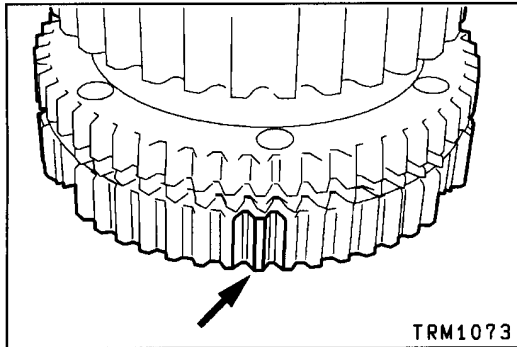

►K◄ FRONT OUTPUT SHAFT / CHAIN / 2WD/4WD SYNCHRONIZER INSTALLATION

- (1) Apply white paint or something similar to the three deep tooth grooves in the 2WD/4WD synchronizer sprocket.

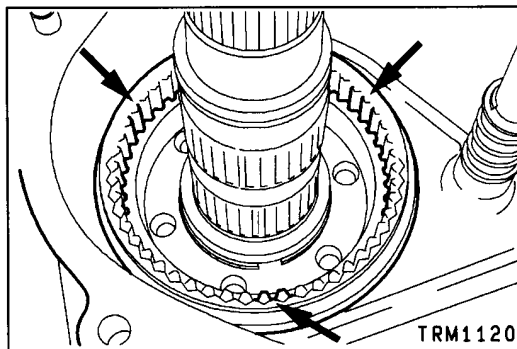

- (2) Apply white paint or something similar to the three spline projections on the synchronizer sleeve.

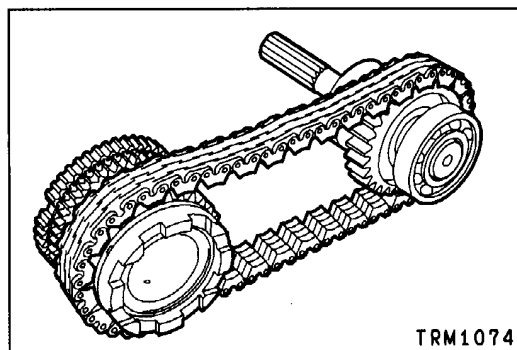

- (3) Mesh the chain with the 2WD/4WD synchronizer sprocket and the front output shaft sprocket.
- (4) With the sprockets distanced as far from each other as possible, install the assembly in the case while aligning the markings made in steps (1) and (2) above.

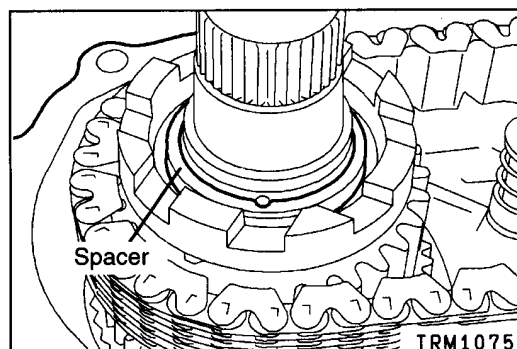

►L◄ SPACER INSTALLATION

- (1) Install the spacer with its oil grooves facing the 2WD/4WD synchronizer.

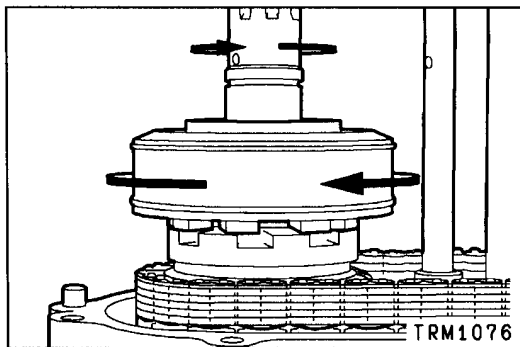

►M◄ VISCIOUS COUPLING INSTALLATION

- (1) If the grooves in the viscous coupling and the 2WD/4WD synchronizer are not aligned, slowly rotate either the rear output shaft or the viscous coupling itself to bring each into alignment.

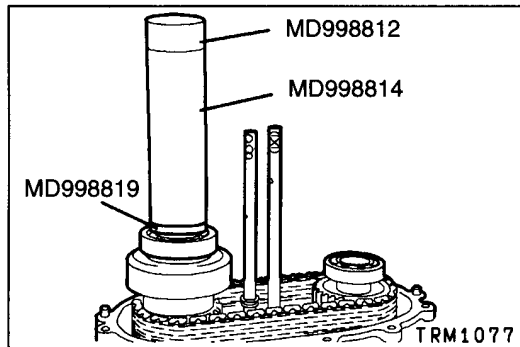

►N◄ BALL BEARING INSTALLATION

- (1) Assemble the ball bearing using the indicated special tools.

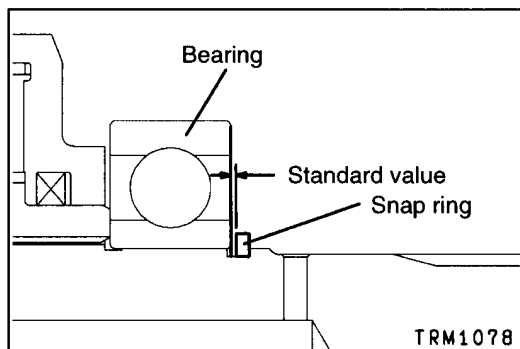

►O◄ SNAP RING INSTALLATION

- (1) Select and install a suitable snap ring to ensure that the rear output shaft rear bearing clearance is at the standard value.

Standard value: 0 – 0.08 mm (0 – 0.0031 in.)

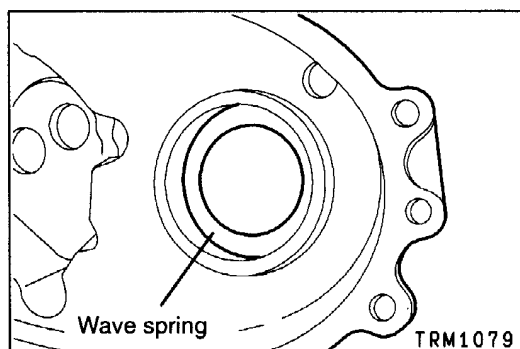

►P◄ WAVE SPRING INSTALLATION

- (1) Apply grease to the wave spring and secure it to the transfer rear cover.

Specified grease:

Mitsubishi genuine grease Part No. MD0101011 or equivalent

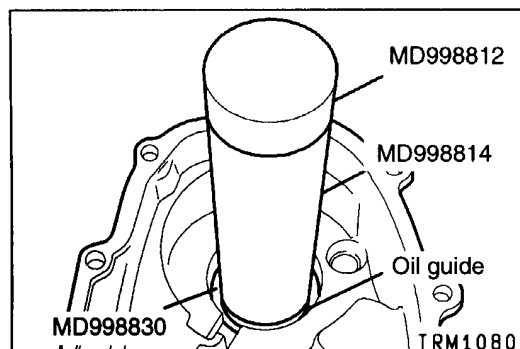

►Q◄ OIL GUIDE INSTALLATION

- (1) Install the oil guide using the indicated special tools.

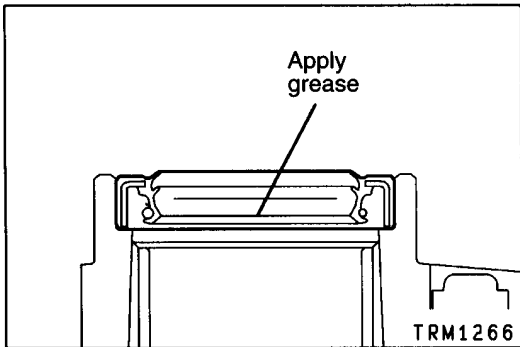

►R◄ OIL SEAL INSTALLATION

- (1) Apply grease to the lip of the oil seal; then assemble the seal using the indicated special tool.

Specified grease:

Mitsubishi genuine grease Part No. MD0101011 or equivalent

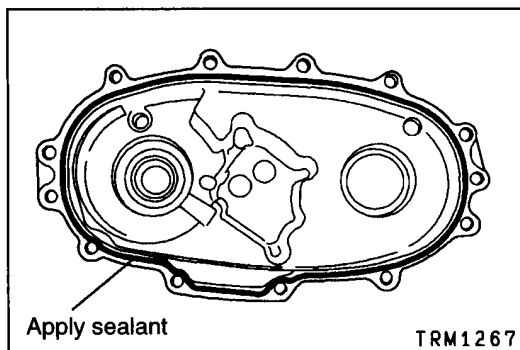
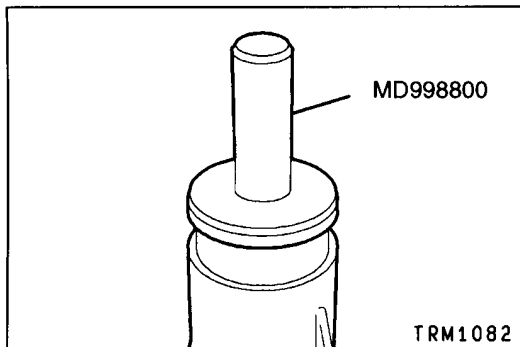

►S◄ TRANSFER REAR COVER INSTALLATION

- (1) Apply sealant to the illustrated position of the transfer rear cover.

Specified sealant:

Mitsubishi genuine sealant Part No. MD997740 or equivalent

Caution

- Squeeze the sealant out evenly to ensure that the bead is not broken and that over-application is not performed.

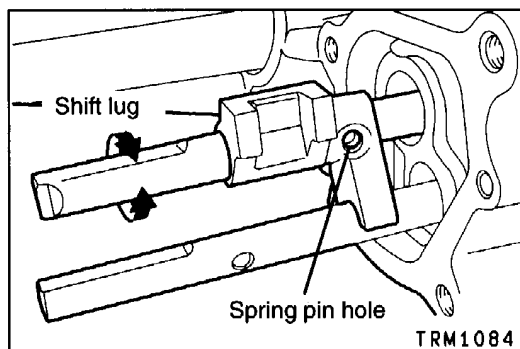

►T◄ 2WD/4WD SHIFT LUG INSTALLATION

- (1) Rotate the 2WD/4WD shift rail to line up the spring pin hole in the 2WD/4WD shift lug with that in the shift rail.

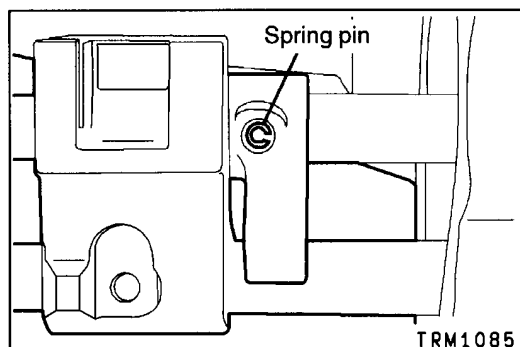

►U◄ SPRING PIN INSTALLATION

- (1) Drive in the spring pin in such a way that its slit is oriented as shown.

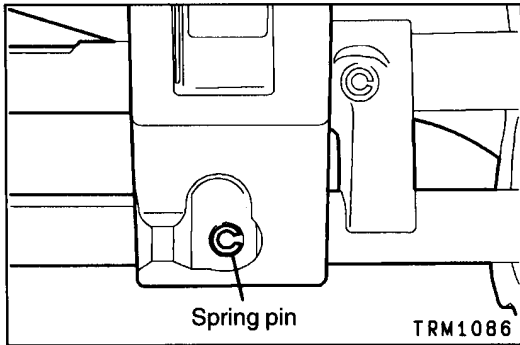

▶V◀ SPRING PIN INSTALLATION

- (1) Drive in the spring pin in such a way that its slit is oriented as shown.

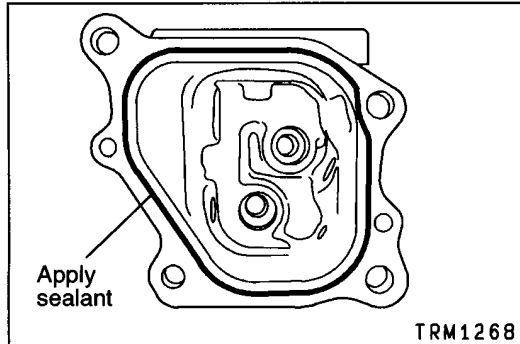

▶W◀ TRANSFER CONTROL HOUSING INSTALLATION

- (1) Apply sealant to the transfer control housing at the indicated position.

Specified sealant:

Mitsubishi genuine sealant Part No. MD997740 or equivalent

Caution

- Squeeze the sealant out evenly to ensure that the bead is not broken and that over-application is not performed.

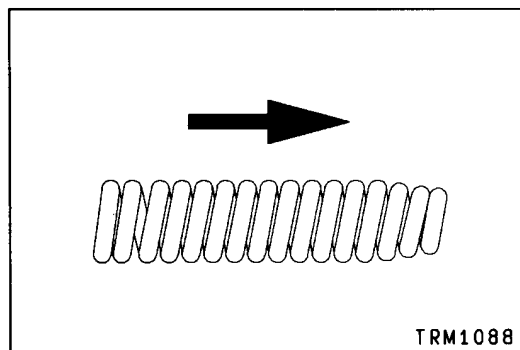

▶X◀ SPRING INSTALLATION

- (1) Install the spring with the tapered end facing the ball side.

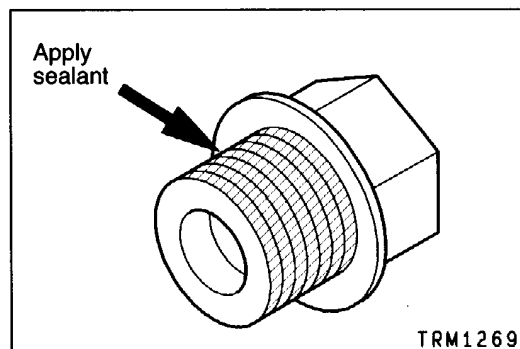

▶Y◀ POPPET SEAL BOLT INSTALLATION (when reused)

- (1) Apply sealant to the threaded area of the poppet seal bolt before tightening to the specified torque.

Specified sealant:

3M ATD Part No. 8660 or equivalent

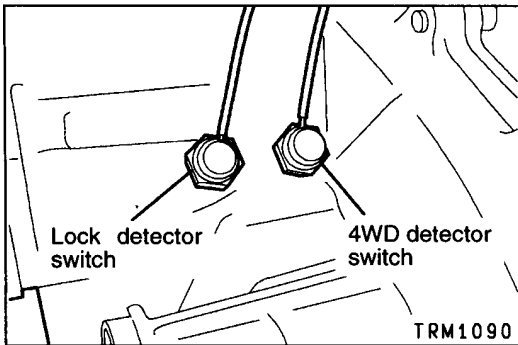

▶Z◀ LOCK DETECTOR SWITCH / 4WD DETECTOR SWITCH INSTALLATION

- (1) Install each of the detector switches at the correct position.

Name	Connector color	Harness tube color
Lock detector switch	Brown	Black
4WD detector switch	White	Black

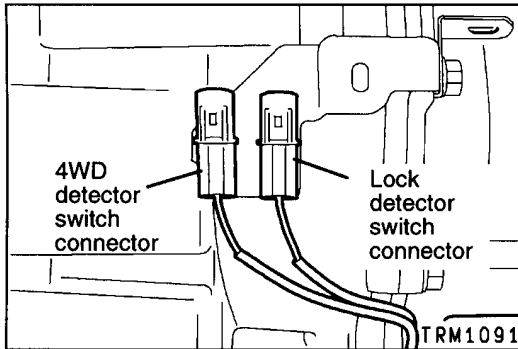

▶a◀ LOCK OPERATION DETECTOR SWITCH INSTALLATION

- (1) Install the detector switch as illustrated.

Name	Connector color	Harness tube color
Lock operation detector switch	Brown	Yellow

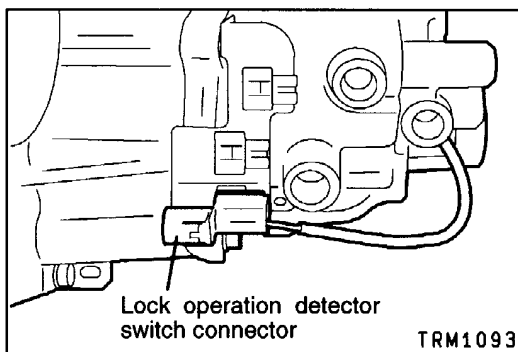
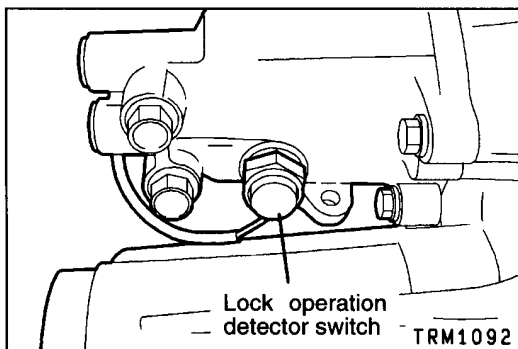

▶b◀ 4WD OPERATION DETECTOR SWITCH / HI-LO DETECTOR SWITCH INSTALLATION

- (1) Install each of these detector switches as illustrated.

Name	Connector color	Harness tube color
4WD operation detector switch	White	Blue
Hi-Lo detector switch	Black	Black

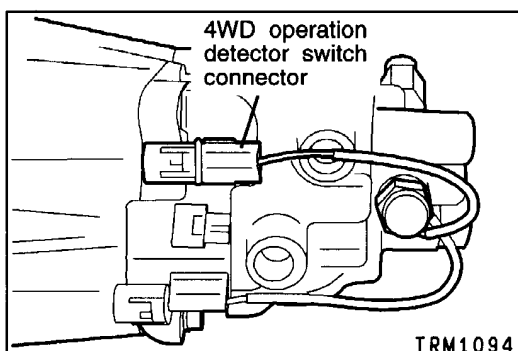

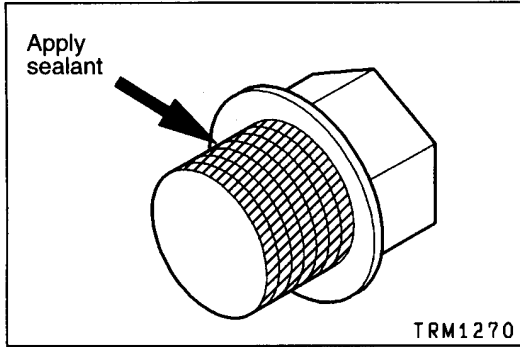
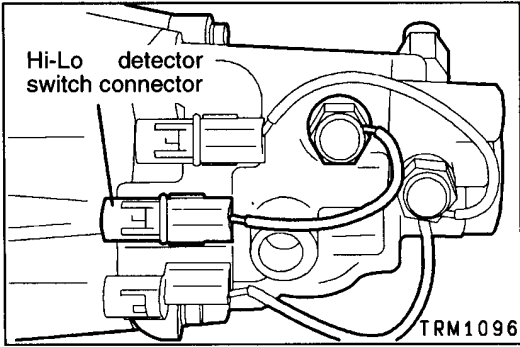

▶◀ SELECT PLUNGER SEAL PLUG INSTALLATION (when reused)

- (1) Apply sealant to the threaded area of the seal plug before tightening to the specified torque.

Specified sealant:
3M ATD Part No. 8660 or equivalent

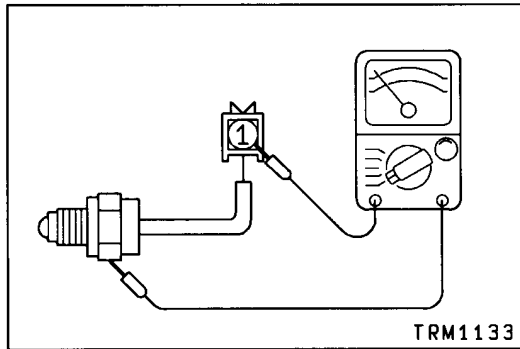

INSPECTION

DETECTOR SWITCHES

- (1) Check each detector switch for continuity between the connector terminal and the switch body.
- (2) Replace the switch if the test results shown below are not obtained.

Names	Connector color	Harness tube color	Switch pressed	Switch released
Hi-Lo detector switch	Black	Black	No continuity	Continuity exists
4WD detector switch	White	Black	No continuity	Continuity exists
Lock detector switch	Brown	Black	No continuity	Continuity exists
4WD operation detector switch	White	Blue	Continuity exists	No continuity
Lock operation detector switch	Brown	Yellow	Continuity exists	No continuity

12. REAR OUTPUT SHAFT
<EXCEPT V5M21-A>

KM145, KM147, V5M21

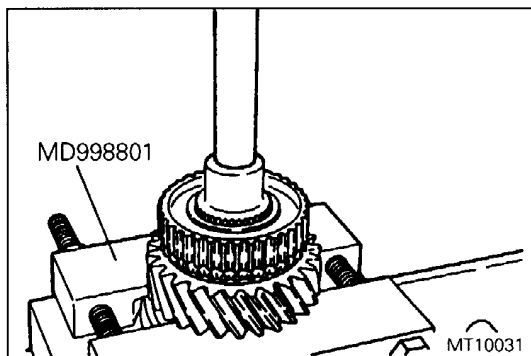
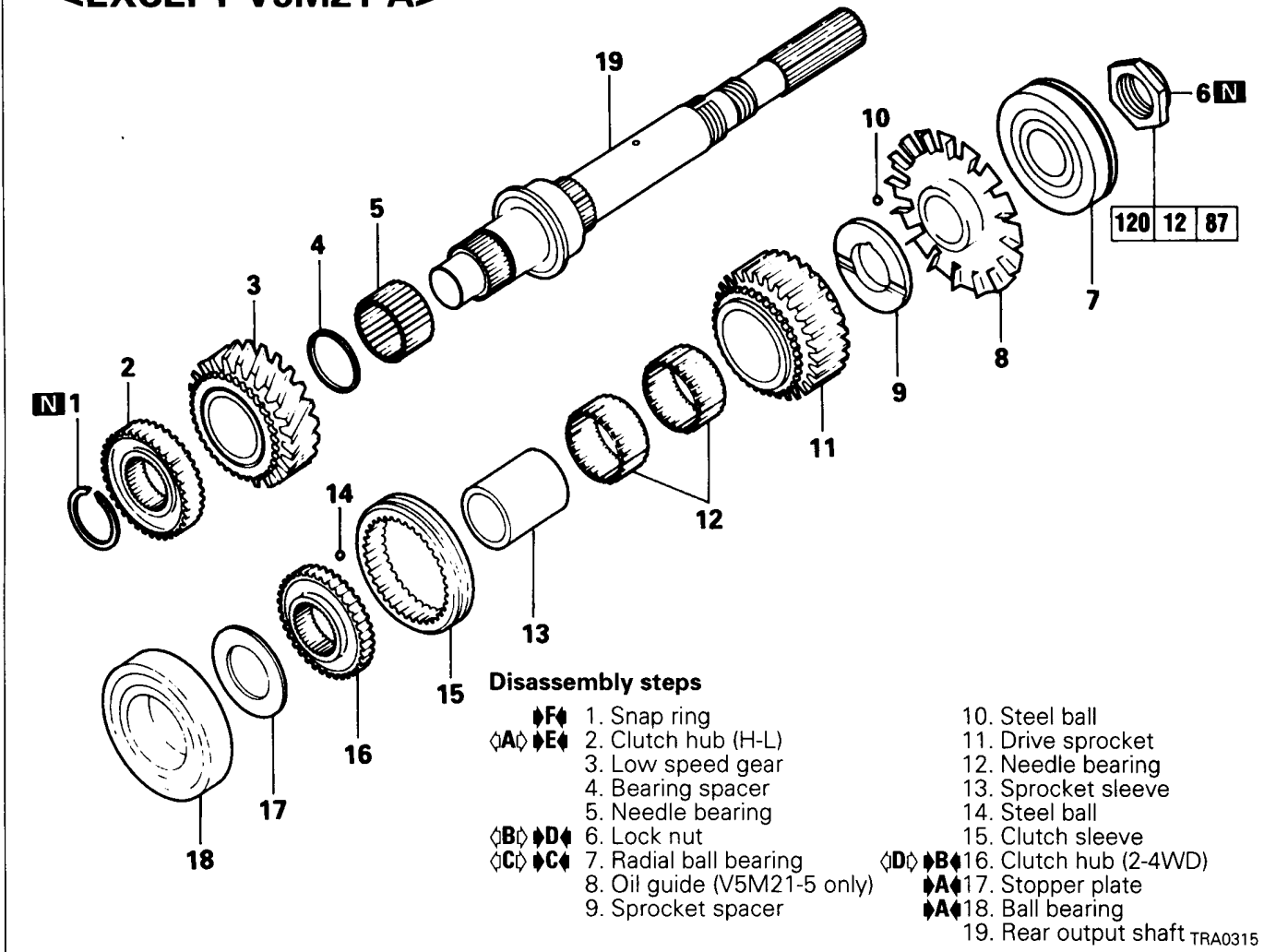

SERVICE POINTS OF DISASSEMBLY

↙A ↘A REMOVAL OF CLUTCH HUB (H-L)

NOTE

Some of the clutch hubs may be removed without using a press.

- (1) Set the special tool so that load may be received by the low speed gear.
- (2) Use a press to push the front end of the rear output shaft and remove the hub and gear.

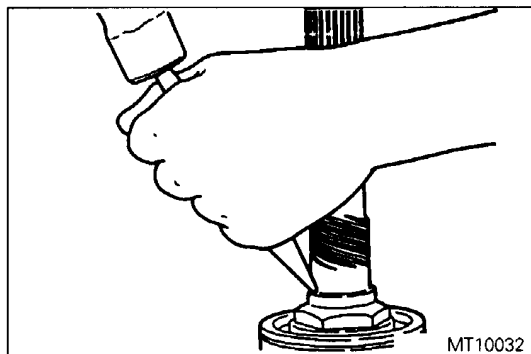

↙B ↘D REMOVAL OF LOCK NUT

- (1) Use a chisel and hammer to set the lock nut free.

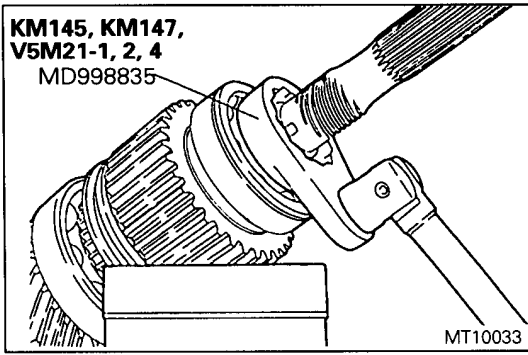

(2) Using the special tool, remove the lock nut.

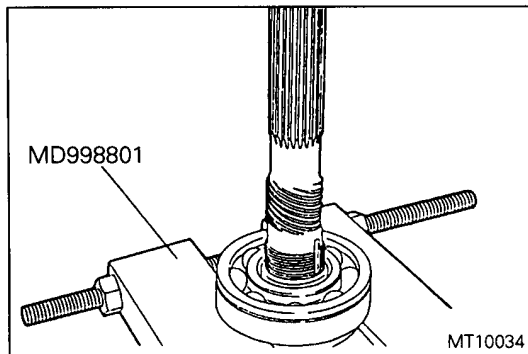
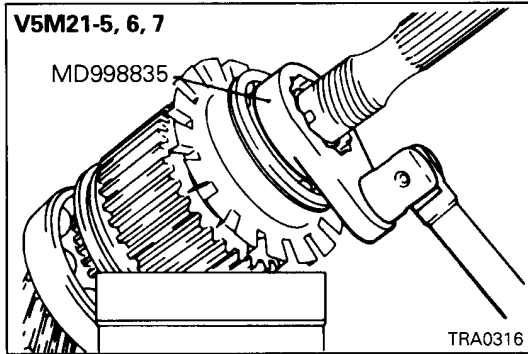

◊C◊ **REMOVAL OF RADIAL BALL BEARING**

NOTE

Some of the bearings are loosely fitted on the shaft and may be removed without using a press.

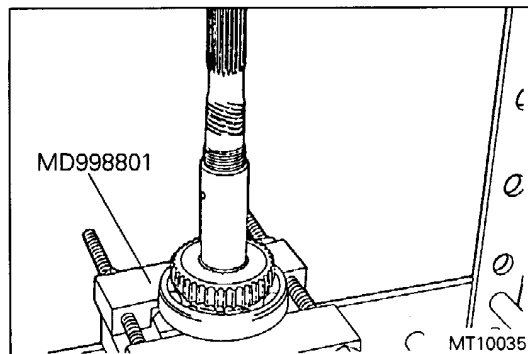

◊D◊ **REMOVAL OF CLUTCH HUB (2-4WD) / BALL BEARING**

NOTE

Some of the 2-4WD clutch hubs may be removed without using a press.

- (1) Set the special tool so that load may be received by the bearing.
- (2) Use a press to push the rear end of the rear output shaft and remove the hub and bearing.

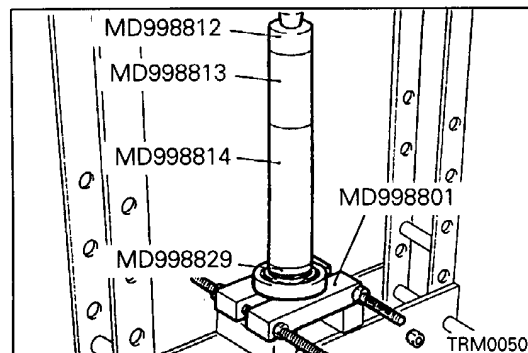

SERVICE POINTS OF REASSEMBLY

▶A▶ **INSTALLATION OF BALL BEARING / STOPPER PLATE**

- (1) Place the stopper plate on the bearing.
- (2) Using a special tool, install the ball bearing on the rear output shaft.

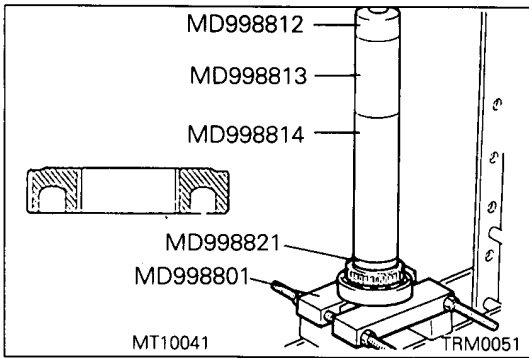

▶B◀ INSTALLATION OF CLUTCH HUB (2-4WD)

- (1) Direct the clutch hub as shown in the illustration to install it to the rear output shaft.

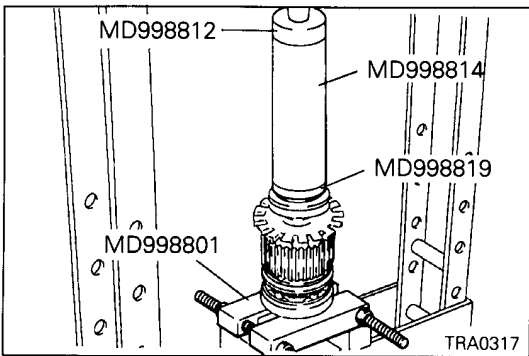

▶C◀ INSTALLATION OF RADIAL BALL BEARING

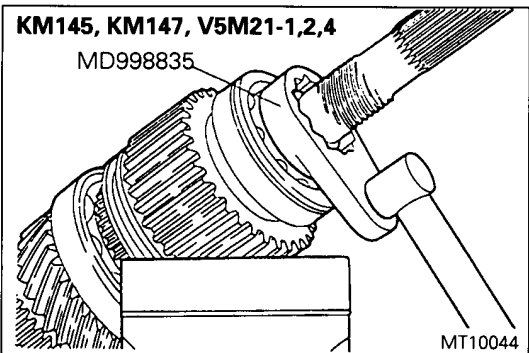

▶D◀ INSTALLATION OF LOCK NUT

- (1) Use the special tool to tighten the rear output shaft lock nut to the specified torque.

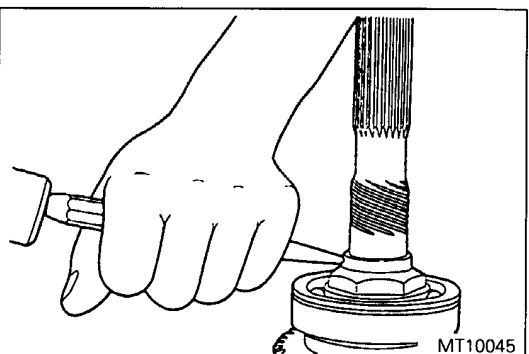
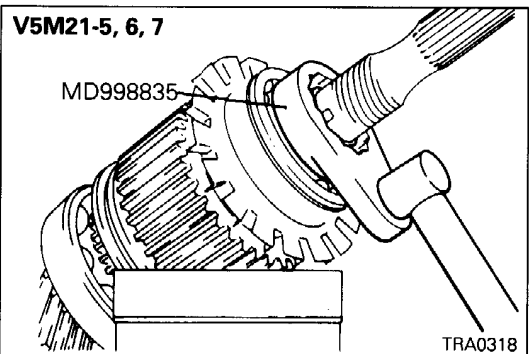

- (2) Use a punch and hammer to secure the lock nut in alignment with the groove in the output shaft.

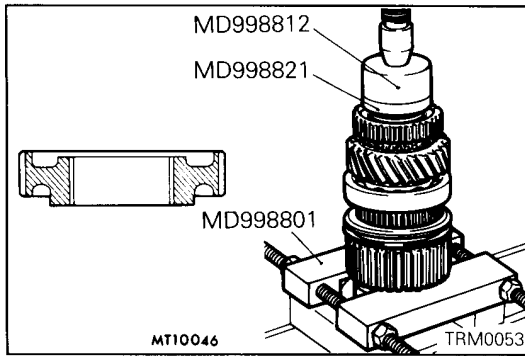

▶E▶ INSTALLATION OF CLUTCH HUB (H-L)

- (1) Use the special tools to install the H-L clutch hub to the rear output shaft.

NOTE

Some of the hubs may be installed without using a press.

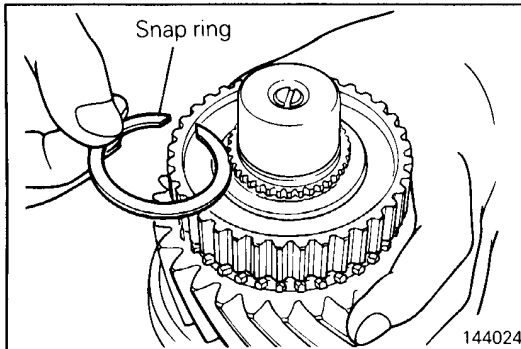

▶F▶ INSTALLATION OF SNAP RING

- (1) Select the thickest snap ring that will fit into the groove in the front end of the rear output shaft and install it.

Standard value: 0 – 0.08 mm (0 – 0.003 in.)

12a. REAR OUTPUT SHAFT <V5M21-A>

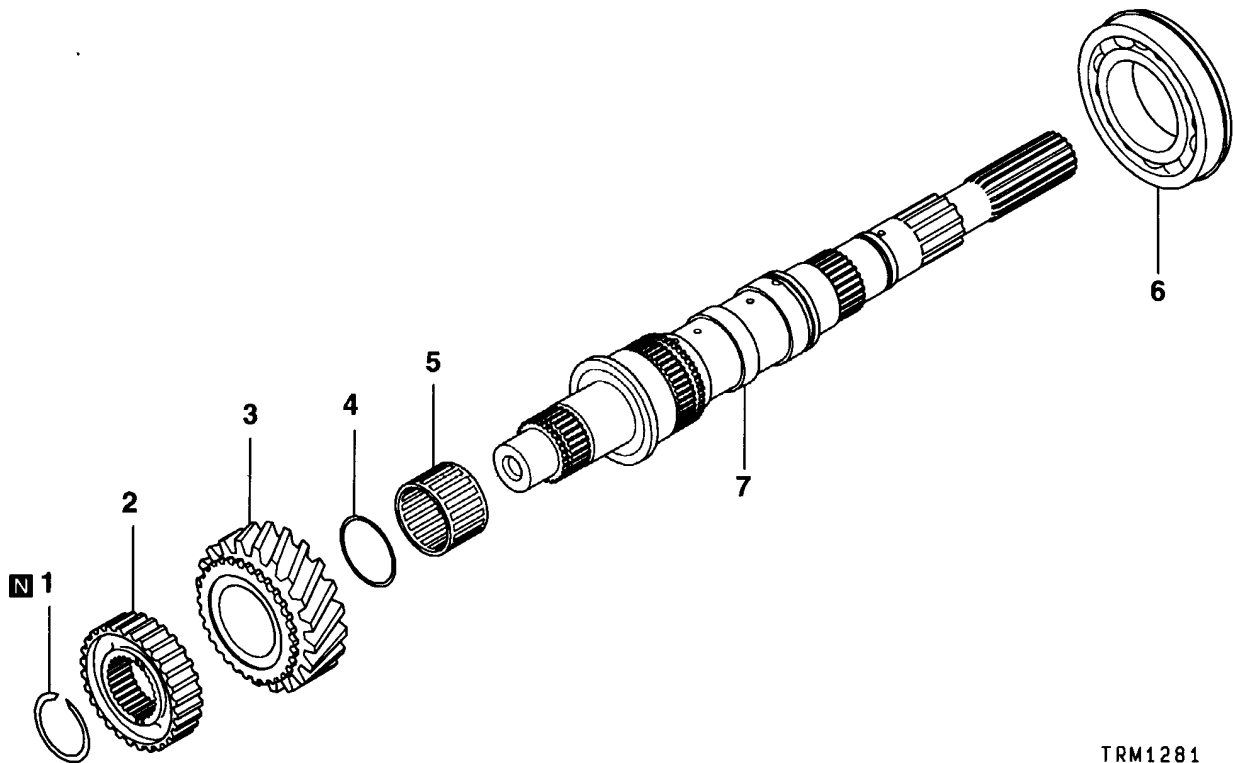

TRM1281

Disassembly steps

- ▶C◀ 1. Snap ring
- ▶B◀ 2. Hi-Lo clutch hub
- 3. Low speed gear
- 4. Bearing spacer
- 5. Needle bearing
- ◀A▶ ▶A▶ 6. Center bearing
- 7. Rear output shaft

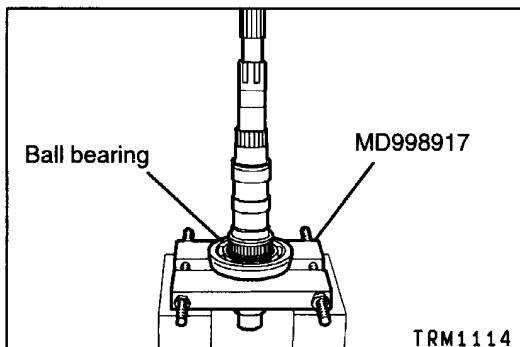

DISASSEMBLY SERVICE POINT

◀A▶ **CENTER BEARING REMOVAL**

- (1) Remove the center bearing using the indicated special tool.

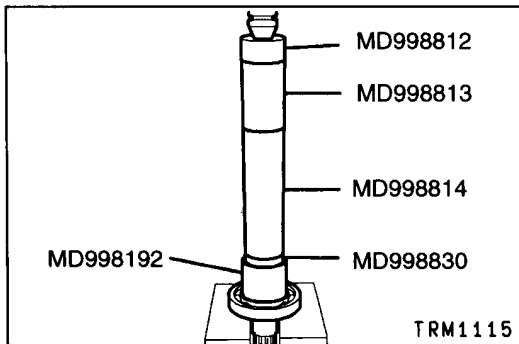

REASSEMBLY SERVICE POINT

▶A◀ CENTER BEARING INSTALLATION

- (1) Install the center bearing using the indicated special tool.

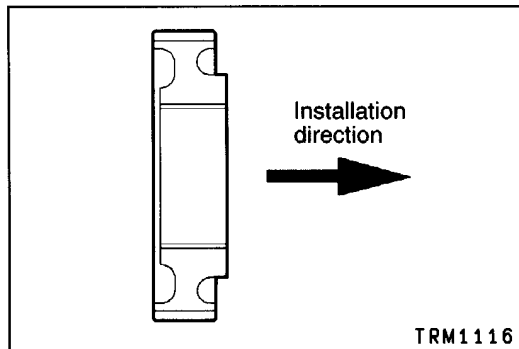

▶B◀ HI-LO CLUTCH HUB INSTALLATION

- (1) Install the Hi-Lo clutch hub in the direction indicated by arrow.

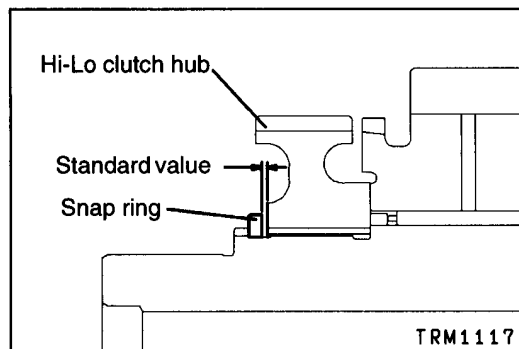

▶C◀ SNAP RING INSTALLATION

- (1) Choose and assemble a suitable snap ring to ensure that the Hi-Lo clutch hub clearance is at the standard value.

Standard value: 0 – 0.08 mm (0 – 0.0031 in.)

13.INPUT SHAFT <EXCEPT V5M21-A>

KM145, KM147, V5M21

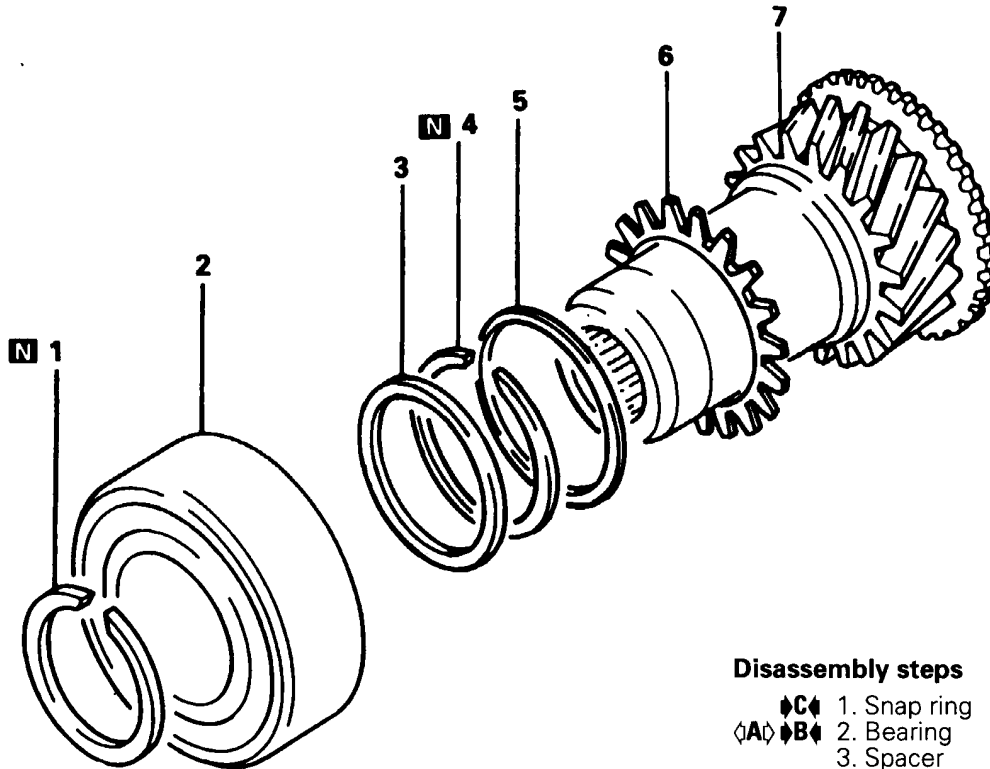

Disassembly steps

- ↕C↕ 1. Snap ring
 - ↕A↕ ↕B↕ 2. Bearing
 - 3. Spacer
 - 4. Snap ring
 - ↕A↕ 5. Cone spring
 - 6. Sub gear
 - 7. Input gear
- } KM145
V5M21-1-Q
V5M21-5, 6, 7

145109

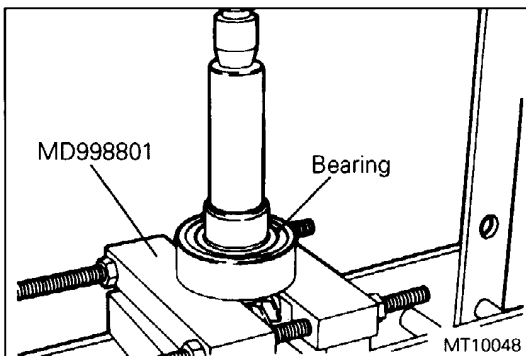

SERVICE POINT OF DISASSEMBLY

↕A↕ **REMOVAL OF BEARING**

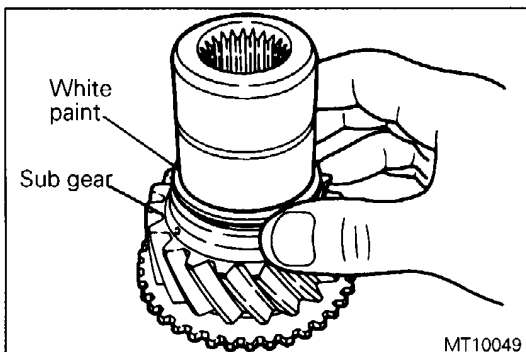

SERVICE POINTS OF REASSEMBLY

↕A↕ **INSTALLATION OF CONE SPRING**

- (1) Install the sub gear to the input gear before installing the cone spring with the white painted side facing up.

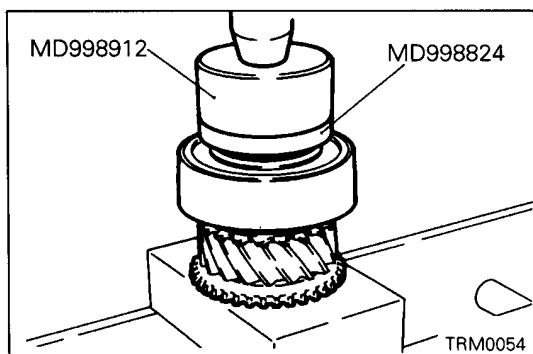
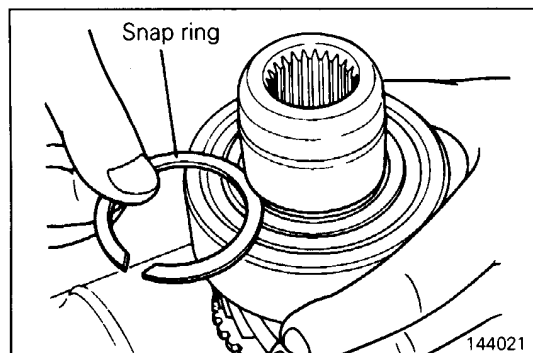
**◆B◆ INSTALLATION OF BEARING****◆C◆ INSTALLATION OF SNAP RING**

- (1) Select the thickest snap ring that will fit into the groove in the front end of the input gear and install it.

Standard value: 0 - 0.06 mm (0 - 0.0024 in.)

13a. INPUT SHAFT <V5M21-A>

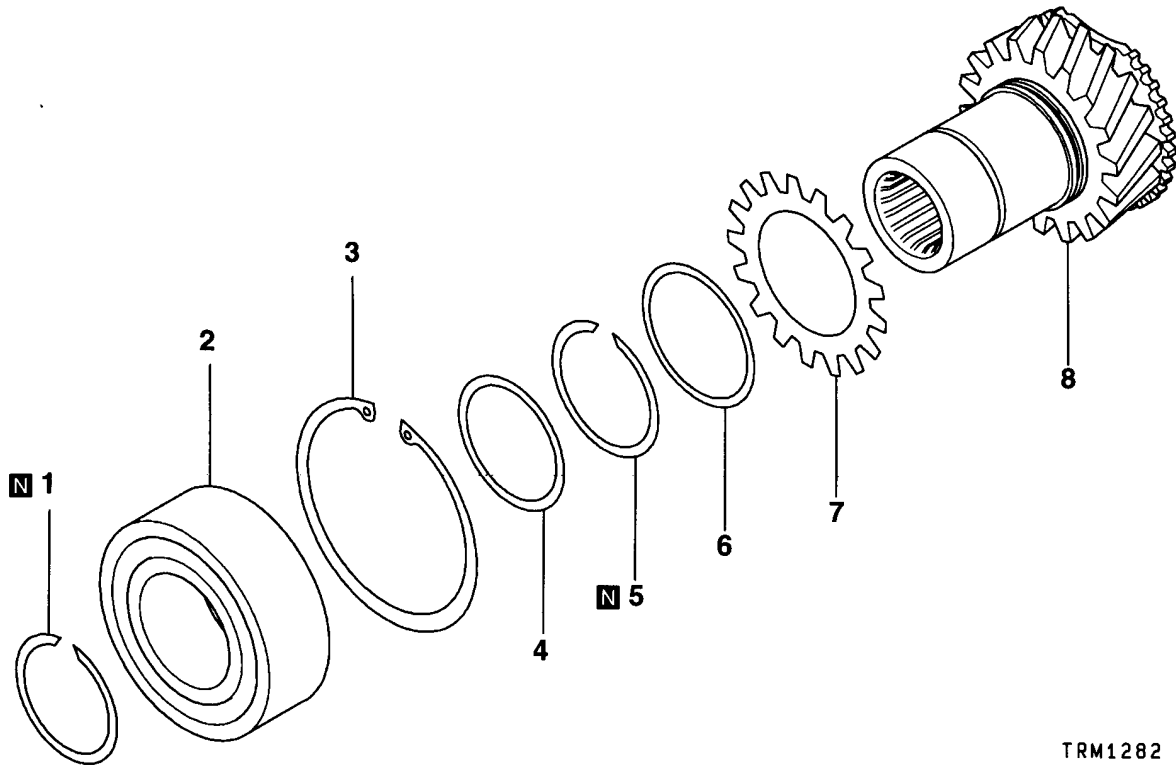

Disassembly steps

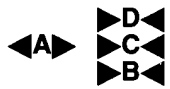

- 1. Snap ring
- 2. Bearing
- 3. Snap ring
- 4. Spacer



- 5. Snap ring
- 6. Cone spring
- 7. Sub gear
- 8. Input gear

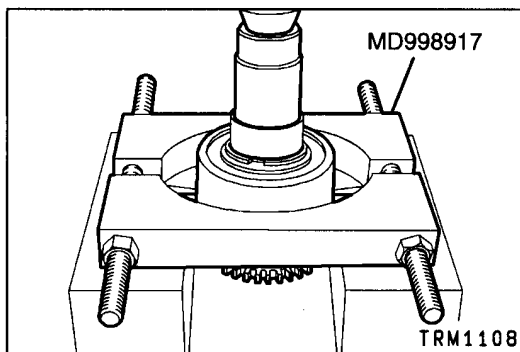

DISASSEMBLY SERVICE POINT

◀A▶ BEARING REMOVAL

- (1) Remove the bearing using the indicated special tool.

Caution

- Do not allow the special tool to contact the spacer.

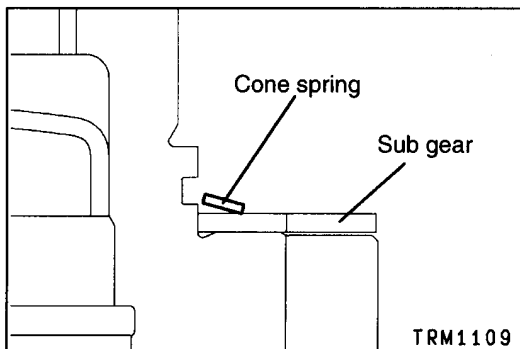

REASSEMBLY SERVICE POINTS

▶A◀ CONE SPRING INSTALLATION

- (1) Install the cone spring in the indicated orientation.

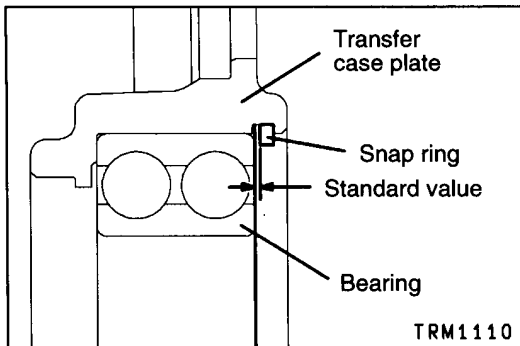

▶B◀ SNAP RING SELECTION

- (1) Install the bearing in the transfer case plate.
- (2) Choose and assemble a suitable snap ring to ensure that the input gear end play is at the standard value.

Standard value: 0 – 0.06 mm (0 – 0.0024 in.)

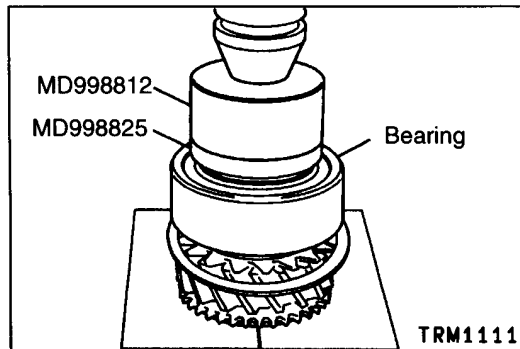

▶C◀ BEARING INSTALLATION

- (1) Install the bearing using the indicated special tool.

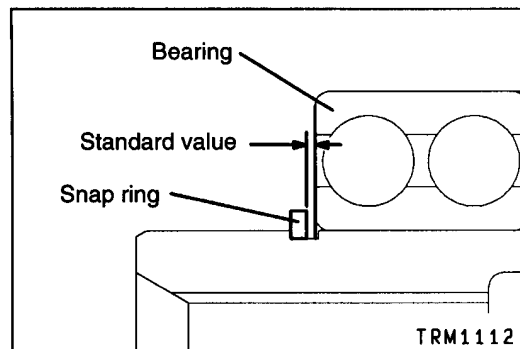

▶D◀ SNAP RING INSTALLATION

- (1) Choose and assemble a suitable snap ring to ensure that the input gear bearing clearance is at the standard value.

Standard value: 0 – 0.06 mm (0 – 0.0024 in.)

14. FRONT OUTPUT SHAFT

KM145, KM147, V5M21

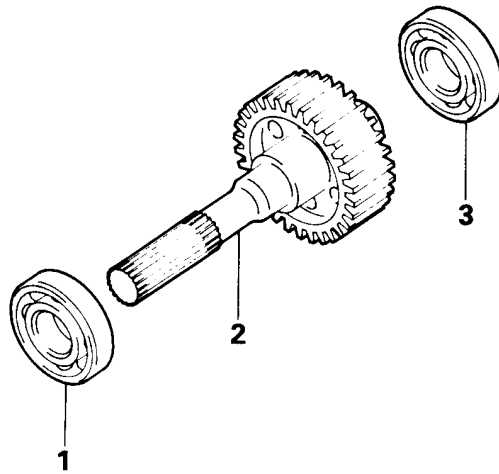

Disassembly steps

- ◊A◊ ▶A▶ 1. Ball bearing
- ◊A◊ ▶A▶ 2. Ball bearing
- 3. Front output shaft

TRA0319

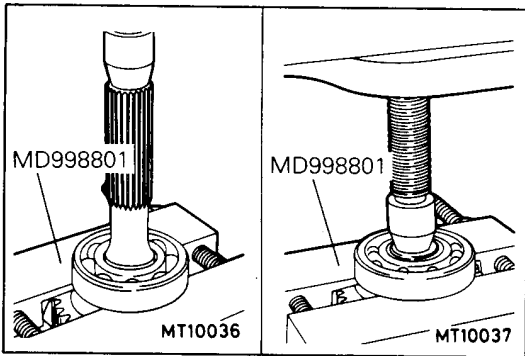

SERVICE POINT OF DISASSEMBLY

◊A◊ REMOVAL OF BALL BEARING

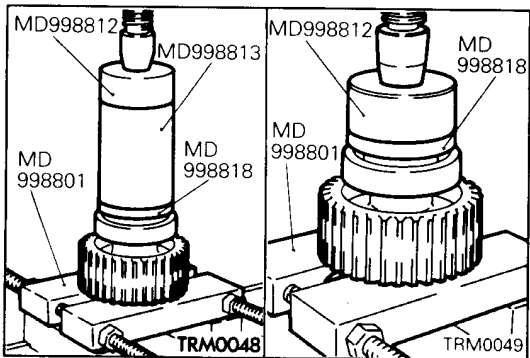

SERVICE POINT OF REASSEMBLY

▶A▶ INSTALLATION OF BALL BEARING

15. H-L SHIFT FORK

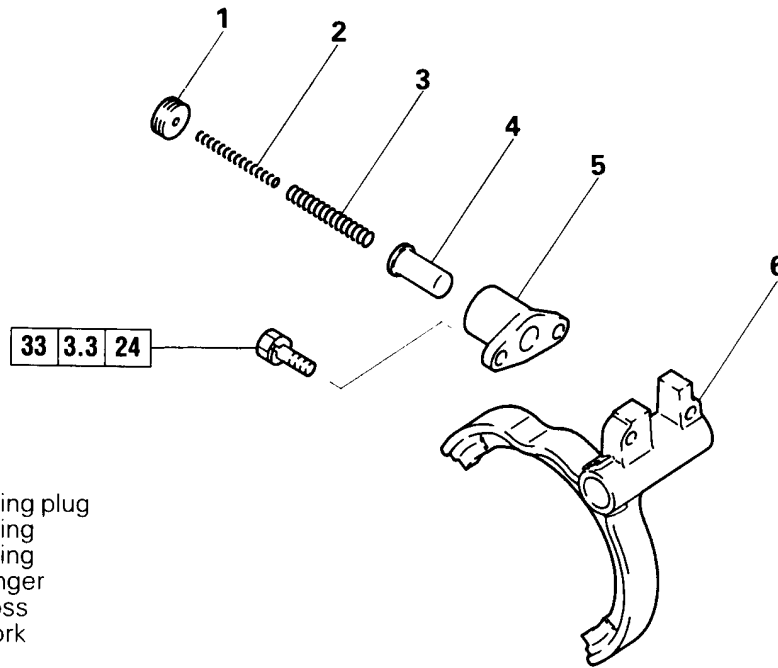

Disassembly steps

- ◆A◆ 1. Return spring plug
- 2. Return spring
- 3. Return spring
- 4. Select plunger
- 5. Plunger boss
- 6. H-L shift fork

TRM0226

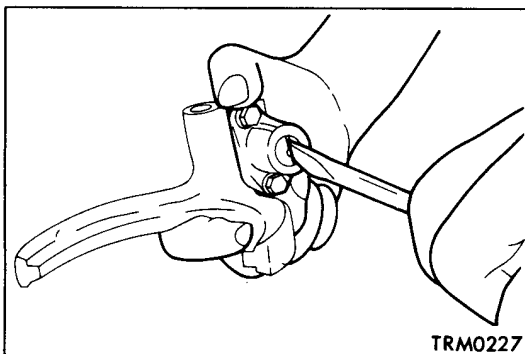

SERVICE POINT OF REASSEMBLY

◆A◆ APPLICATION OF SEALANT TO RETURN SPRING PLUG

- (1) Apply a sealant to the return spring plug and thread the plug in until it is flush with the plunger boss end.

Specified sealant:

3M Super Weatherstrip No. 8001 or equivalent

TRM0227

16. 2WD/4WD SHIFT FORK AND RAIL <V5M21-A>

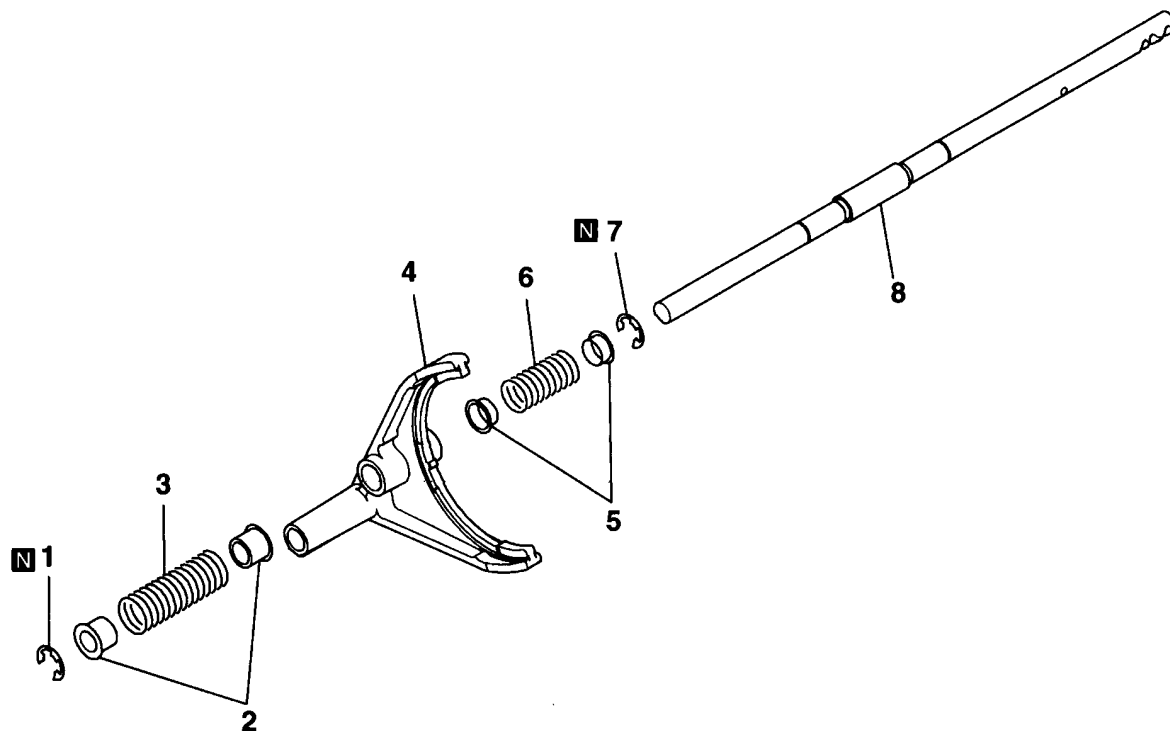

TRM1283

Disassembly steps

1. Snap ring
2. Spring retainers
3. Return spring
4. 2WD/4WD shift fork
5. Spring retainers
6. Return spring
7. Snap ring
8. 2WD/4WD shift rail

17. 2WD/4WD SYNCHRONIZER <V5M21-A>

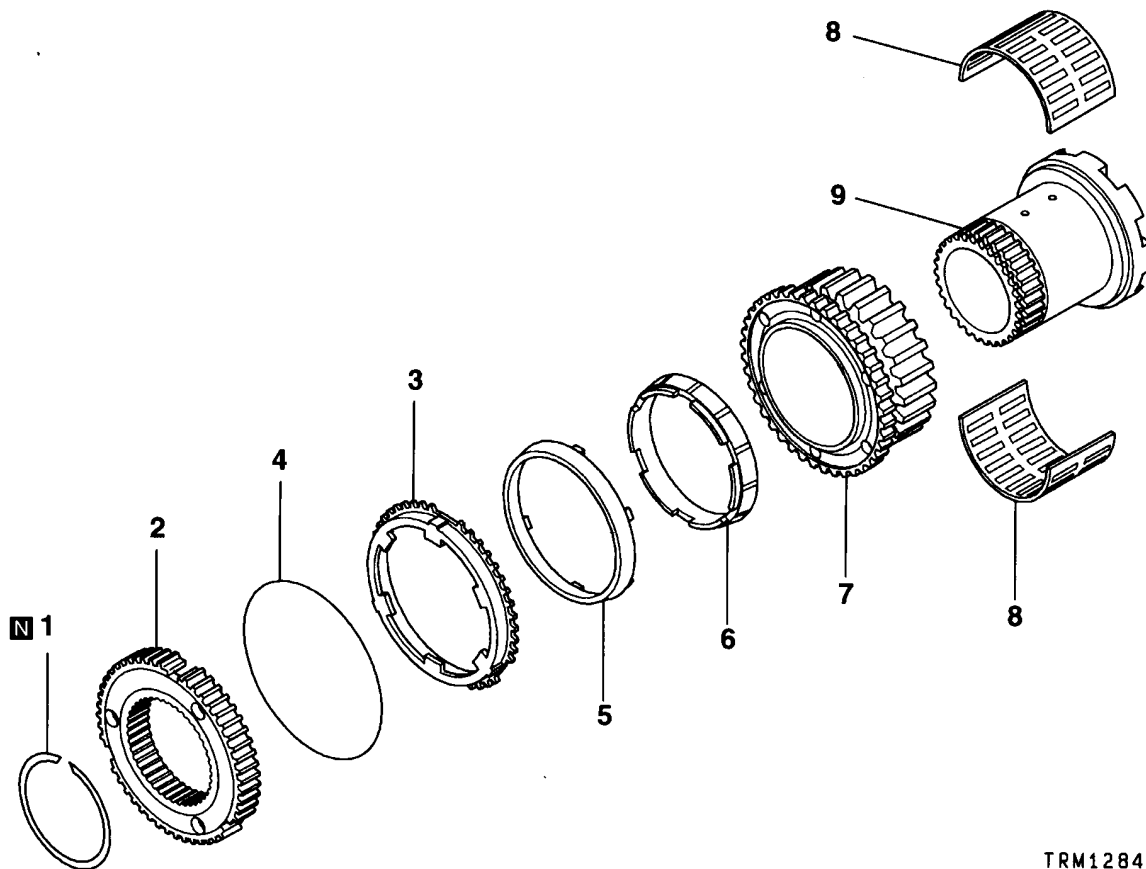

TRM1284

Disassembly steps

- ▶C◀ 1. Snap ring
- ▶B◀ 2. 2WD/4WD clutch hub
- ▶A◀ 3. Outer synchronizer ring
- ▶A◀ 4. Synchronizer spring
- 5. Synchronizer cone
- 6. Inner synchronizer ring
- 7. Drive sprocket
- 8. Needle bearing
- 9. Front input sleeve

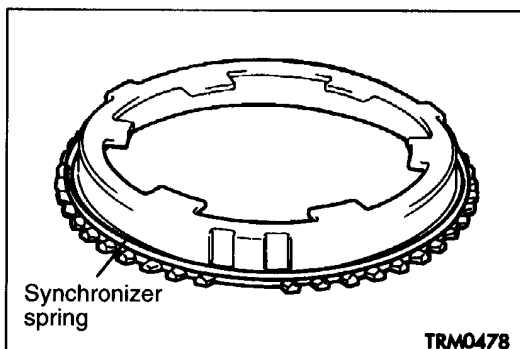

TRM0478

REASSEMBLY SERVICE POINTS

▶A◀ **SYNCHRONIZER SPRING INSTALLATION**

- (1) Securely mount the synchronizer spring on the outer synchronizer ring.

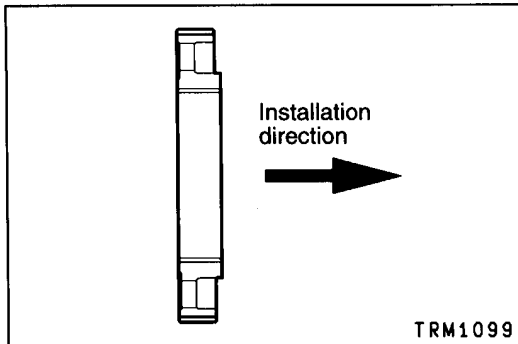

▶B◀ 2WD/4WD CLUTCH HUB INSTALLATION

- (1) Install the 2WD/4WD clutch hub in the arrowed direction.

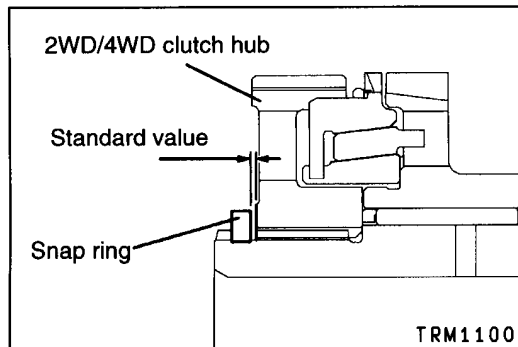

▶C◀ SNAP RING INSTALLATION

- (1) Choose and assemble a suitable snap ring to ensure that the 2WD/4WD clutch hub end play is at the standard value.

Standard value: 0 – 0.08 mm (0 – 0.0031 in.)

18. TRANSFER CASE PLATE <V5M21-A>

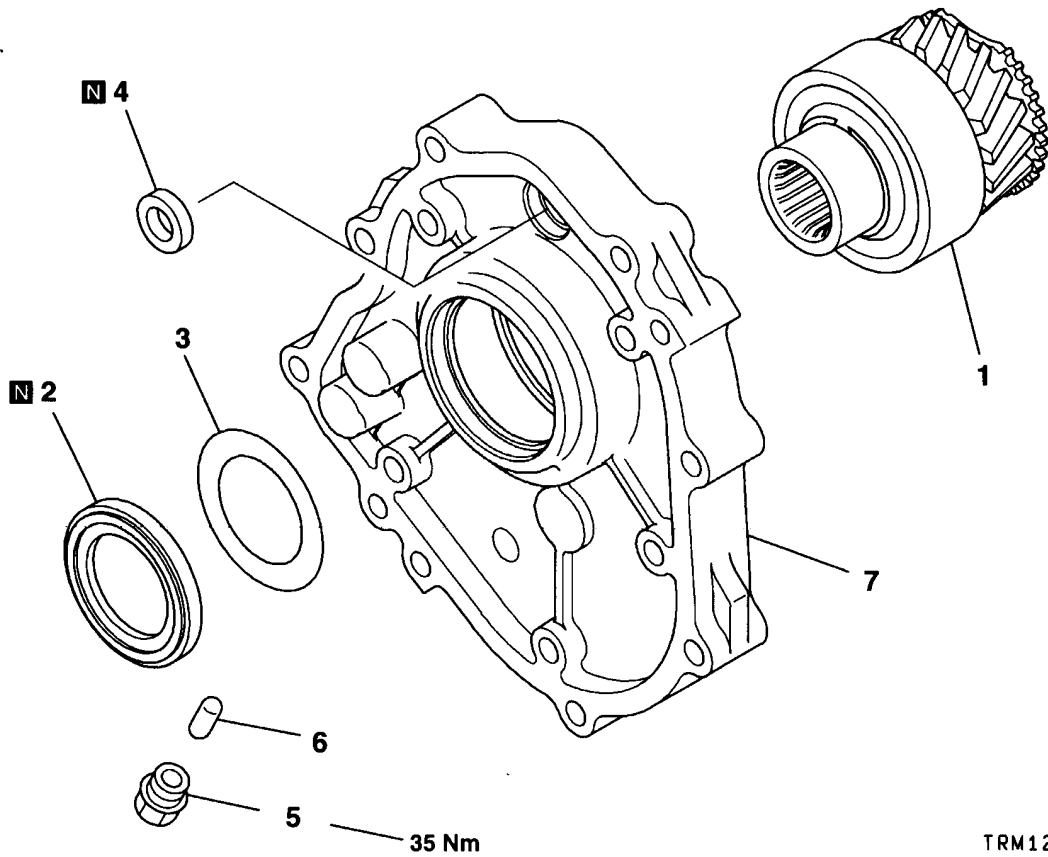

Disassembly steps

- ▶C◀ 1. Input shaft
- ▶B◀ 2. Oil seal
- ▶A◀ 3. Baffle plate
- ▶B◀ 4. Oil seal
- ▶A◀ 5. Interlock plunger seal bolt
- ▶A◀ 6. Interlock plunger
- 7. Transfer case plate

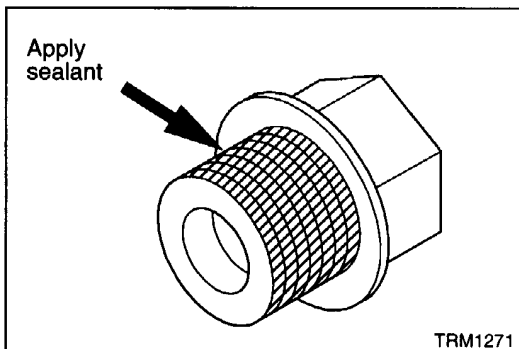

REASSEMBLY SERVICE POINTS

▶A◀ **INTERLOCK PLUNGER SEAL BOLT INSTALLATION (when reused)**

- (1) Apply sealant to the threaded area of the seal bolt before tightening to the specified torque.

Specified sealant:

3M ATD Part No. 8660 or equivalent

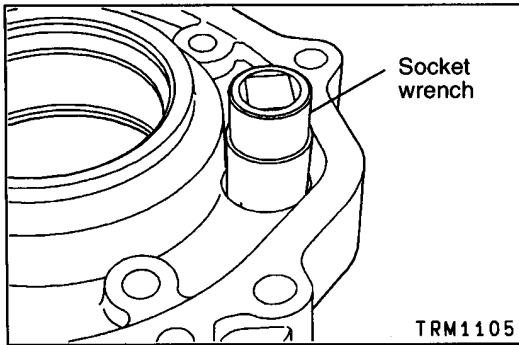

▶B◀ OIL SEAL INSTALLATION

- (1) Install the oil seal using a socket wrench or some other similar tool. After installation, apply grease to the lip of the oil seal.

Specified grease:

**Mitsubishi genuine grease Part No. MD0101011
or equivalent**

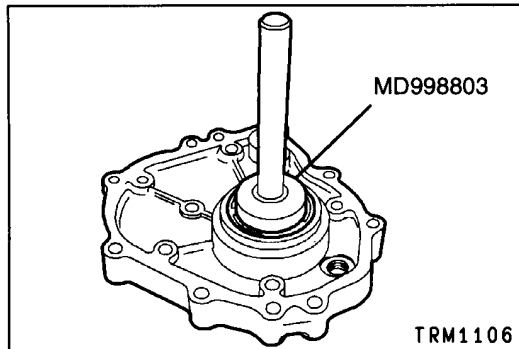

▶C◀ OIL SEAL INSTALLATION

- (1) Install the oil seal using the indicated special tool. Following this, apply grease to the lip of the oil seal.

Specified grease:

**Mitsubishi genuine grease Part No. MD0101011
or equivalent**