

AUTOMATIC TRANSMISSION

F4AC1

CONTENTS

GENERAL INFORMATION	23C-0- 3	4. INPUT CLUTCHES-RECONDITION	23C-4- 1
1. SPECIFICATIONS	23C-1- 1	DISASSEMBLY	23C-4- 1
TRANSMISSION MODEL TABLE	23C-1- 1	REASSEMBLY	23C-4- 4
GEAR RATIO TABLE	23C-1- 1	5. VALVE BODY-RECONDITION	23C-5- 1
SERVICE SPECIFICATIONS	23C-1- 1	6. OIL PUMP SEAL REPLACE	23C-6- 1
SEALANTS	23C-1- 2	7. DIFFERENTIAL REPAIR	23C-7- 1
TORQUE SPECIFICATIONS	23C-1- 2	8. BEARING ADJUSTMENT PROCEDURE	23C-8- 1
2. SPECIAL TOOLS	23C-2- 1	GENERAL RULES ON SERVICING BEARING	23C-8- 1
3. TRANSMISSION-RECONDITION ..	23C-3- 1	OUTPUT GEAR BEARING	23C-8- 1
DISASSEMBLY	23C-3- 1	DIFFERENTIAL BEARING	23C-8- 2
REASSEMBLY	23C-3-11	TRANSFER SHAFT BEARING	23C-8- 3
DETERMINING No.4 THRUST PLATE THICKNESS; INPUT SHAFT END PLAY	23C-3-12		

GENERAL INFORMATION

SECTIONAL VIEW

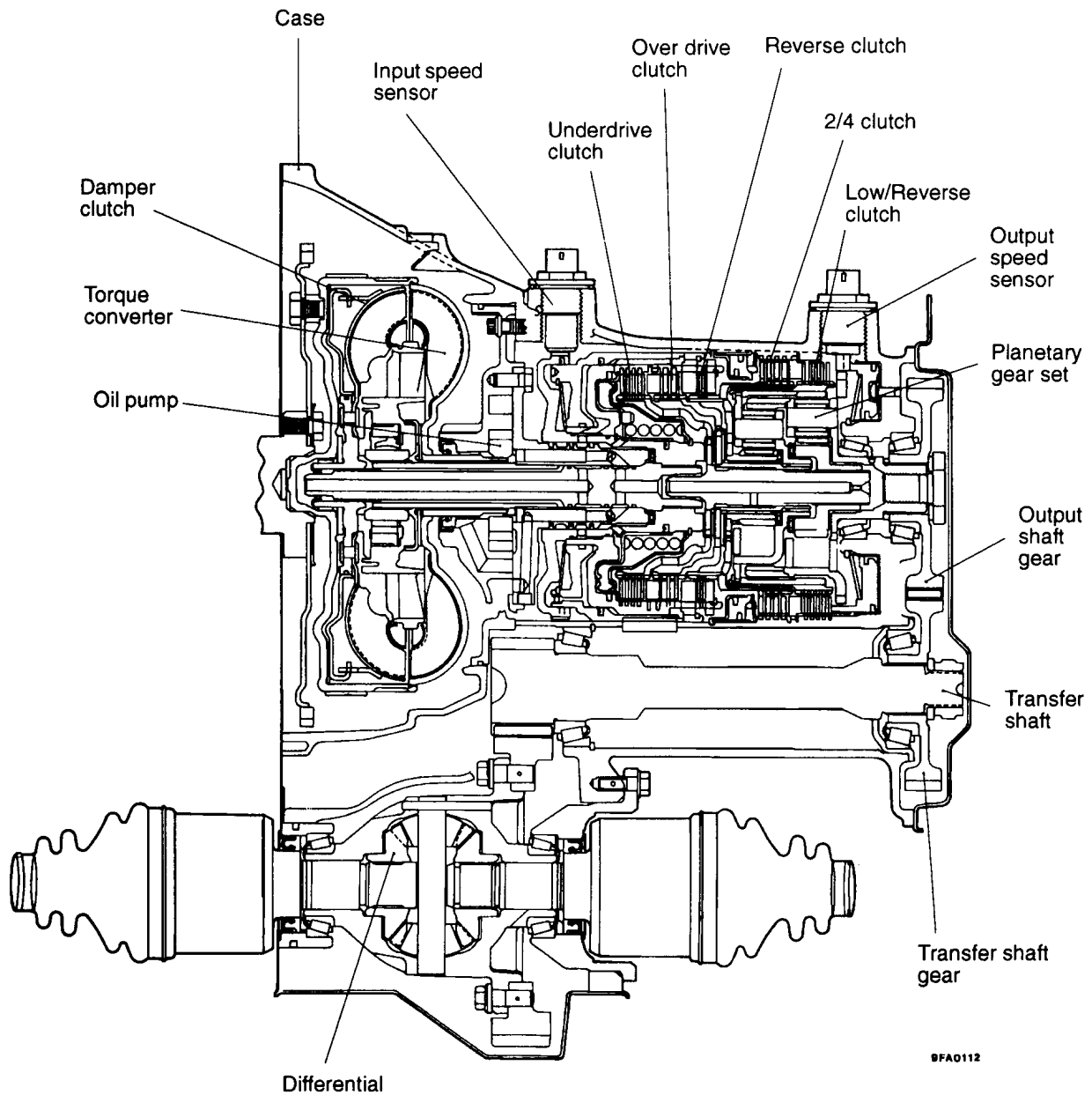

9FA0112

1. SPECIFICATIONS

TRANSMISSION MODEL TABLE

Transmission model	Gear ratio	Final gear ratio	Vehicle model	Engine model
EC	F4AC1-1-QZAF	A	E99A	420B

GEAR RATIO TABLE

	A
1st	2.84
2nd	1.57
3rd	1.00
4th	0.69
5th	2.21

SERVICE SPECIFICATIONS

mm

Items	Specifications
Standard values	
Oil pump outer gear to pocket clearance	0.045–0.141
Oil pump outer gear side clearance	0.020–0.046
Oil pump inner gear side clearance	0.020–0.046
Output gear bearing preload	0.02–0.05
Transfer shaft bearing end play	0.05–0.10
Differential bearing preload	0.15–0.29
Underdrive clutch clearance	0.091–1.47
Overdrive clutch clearance	1.07–2.44
Reverse clutch clearance	0.76–1.24
2/4 clutch clearance	0.76–2.64
Low/reverse clutch clearance	1.04–1.65



SEALANTS

Items	Specified sealant	Quantity
Oil pan	Loctite 5699 or equivalent	As required
Rear cover	Loctite 5699 or equivalent	As required
Rear cover bolts	Loctite 5699 or equivalent	As required
Differential cover	Loctite 5699 or equivalent	As required
Differential bearing retainer	Loctite 5699 or equivalent	As required
Differential bearing retainer bolts	Loctite 5699 or equivalent	As required
Extention	Loctite 5699 or equivalent	As required



TORQUE SPECIFICATIONS

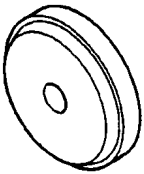
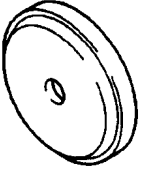
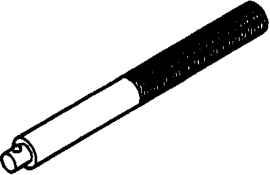

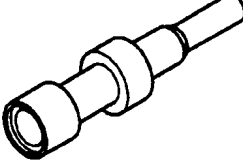
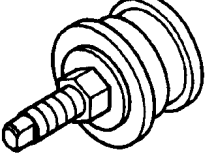
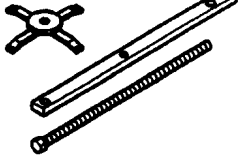
Items	Nm
Transfer shaft gear nut	271
Output gear bolt	271
Clutch housing to transmission case bolts	28

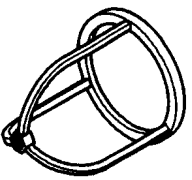
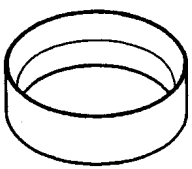
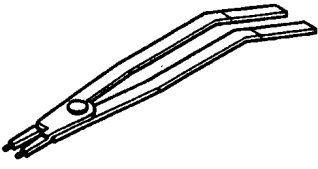
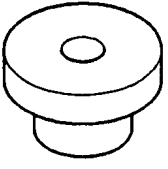
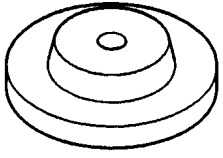
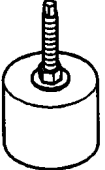
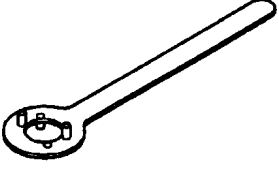
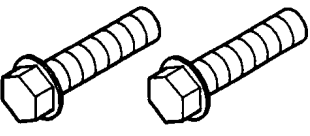
2. SPECIAL TOOLS

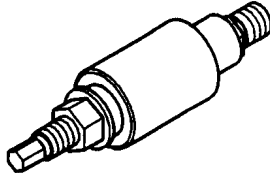
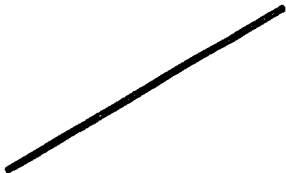
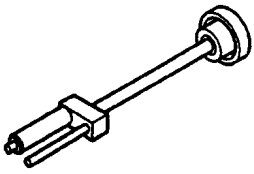
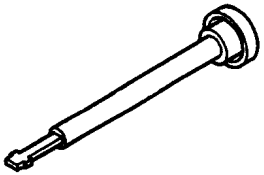
Tool	Number	Name	Use
	MB990933	Installer adapter	Installation of differential bearing retainer bearing cup.
	MB990936	Installer adapter	Installation of transfer shaft gear bearing cup, output bearing cup.
	MB990938	Installer bar	Use with MB990933, MB990936.
	MB995001	Bearing puller	Removal of transfer shaft gear bearing race, rear carrier cone.
	MB995002	Bearing puller	Removal of rear carrier cone.
	MB995003	Installer remover	Installation and removal of transfer shaft.
	MB995004	Bearing cap installer	Installation of output bearing cup.
	MB995005	Spring compressor	Removal of 2/4 clutch retainer snap ring. Installation and removal of low-reverse clutch snap ring.

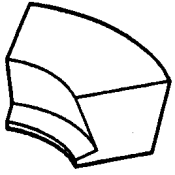
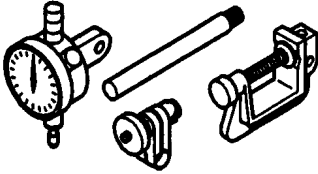
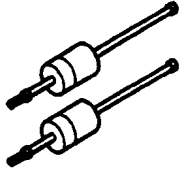
Tool	Number	Name	Use
	MB995006	Spring compressor	Installation and removal of low-reverse clutch snap ring, underdrive clutch spring retainer snap ring.
	MB995007	Seal installer	Installation of underdrive clutch spring retainer snap ring.
	MB995008	Snap ring plier	Installation and removal of transfer shaft bearing snap ring.
	MB995009	Thrust button	Removal of output gear, rear carrier cone.
	MB995010	Disc	Installation and removal of low-reverse clutch snap ring, overdrive piston snap ring.
	MB995011	Bearing cup remover	Removal of transfer shaft gear bearing cup, output bearing cup.
	MB995012	Holder	Installation and removal of transfer shaft gear nut, output gear bolt. Adjustment of output gear, transfer shaft.
	MB995013	Special bolts	Adjustment of output gear clearance.

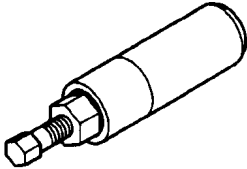
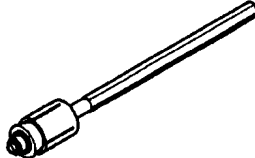
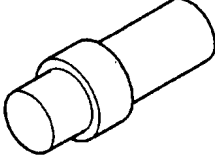
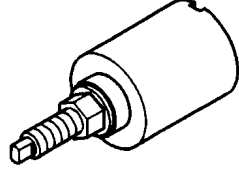
Tool	Number	Name	Use
	MB995014	Gear installer	Installation of transfer shaft gear.
	MB995015	Dial indicator tip	Adjustment of low-reverse clutch.
	MB995016	Installer remover	Installation and removal of T/C control valve, T/C clutch switch valve.
	MB995017	Installer remover	Installation and removal of regulator valve.
	MB995028	Puller	Removal of differential bearing cone.
	MB995029	Adapter blocks	Removal of differential bearing cone.
	MB995030	Dial indicator set	Adjustment of underdrive clutch clearance, overdrive clutch.
	MB995031	Puller set	Removal of oil pump.

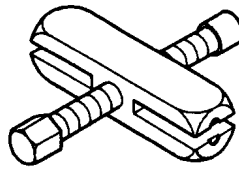
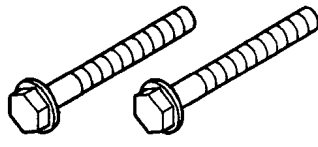
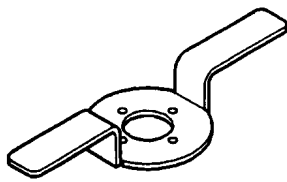
Tool	Number	Name	Use
	MB995032	Seal remover	Removal of oil pump oil seal.
	MB995038	Differential bearing torque tool	Adjustment of differential bearing.
	MB995039	Adapter	Removal of differential bearing cone. Adjustment of differential side gear clearance.
	MB995041	Bearing and gear remover	Removal of differential bearing cone.
	MB995042	Bearing and gear remover	Removal of differential bearing cone.
	MB995043	Gear puller	Removal of transfer shaft gear, output gear. Adjustment of output gear clearance, transfer shaft.
	MB995044	Bolts	Removal of transfer shaft gear, output gear. Adjustment of output gear clearance, transfer shaft.
	MB995045	Fixture	Adjustment of output gear clearance, transfer shaft.

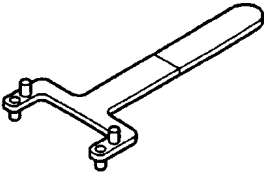
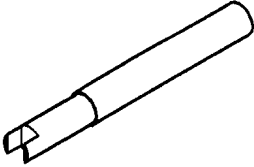
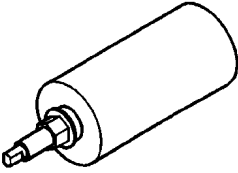
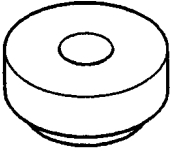
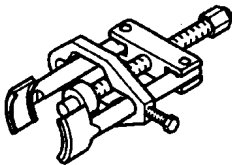
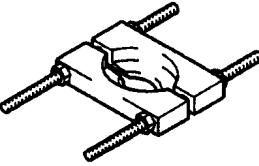
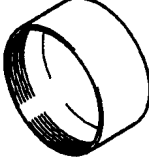
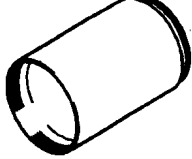
Tool	Number	Name	Use
	MB995046	Remover	Installation and removal of differential bearing retainer.
	MB995047	Checking tool	Adjustment of differential clearance, differential turning drive torque.
	MB995048	Cup remover	Removal of differential bearing retainer bearing cup. Adjustment of differential bearing.
	MB995049	Button	Removal of transfer shaft gear bearing cone.
	MD998348	Bearing and gear puller	Removal of transfer shaft gear bearing cone.
	MD998801	Bearing remover	Removal of transfer shaft bearing cone.
	MD998812	Installer cap	Use with MD998813, MD998814, MD998821, MD998823, MD998825, MD998827.
	MD998813	Installer-100	Use with MD998812, MD998821, MD998825.

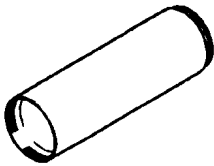
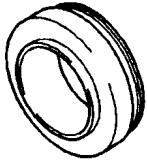
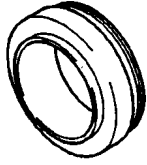
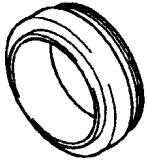
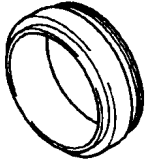
Tool	Number	Name	Use
	MD998814	Installer-200	Use with MD998812, MD998821.
	MD998821	Installer adapter (44)	Installation of transfer shaft bearing cone, rear carrier cone.
	MD998823	Installer adapter (48)	Installation of transfer shaft gear bearing cone, output bearing cone.
	MD998825	Installer adapter (52)	Installation of oil pump oil seal.
	MD998827	Installer adapter (56)	Installation of differential oil seal, differential bearing retainer bearing cup.

3. TRANSMISSION–RECONDITION

DISASSEMBLY

Disassemble according to illustration numbers.

Tag all clutch pack assemblies, as they are removed, for reassembly identification.

Caution

- Do not intermix clutch discs or plates, or the unit might fail.

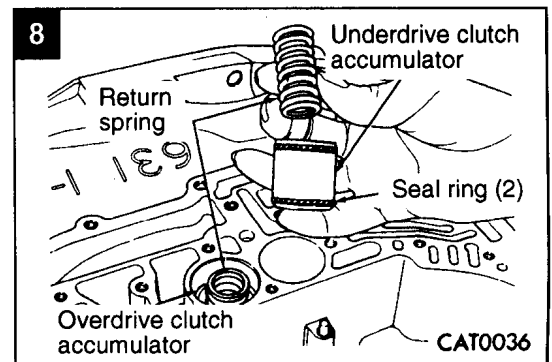
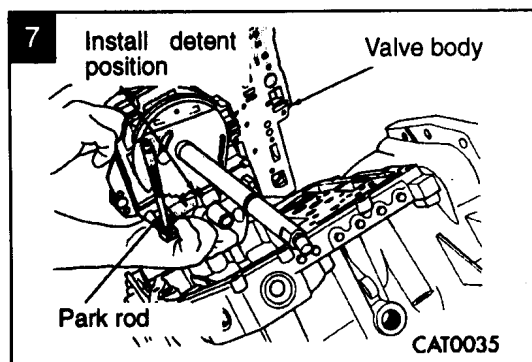
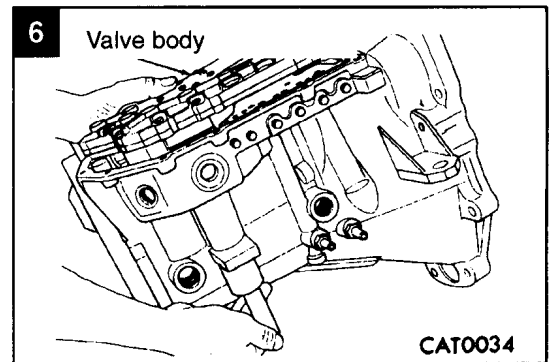
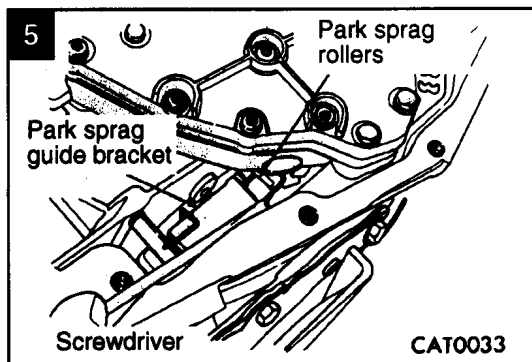
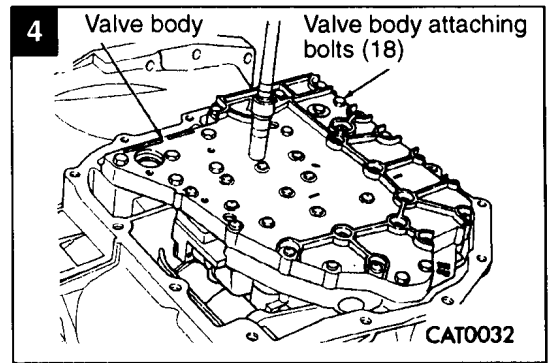
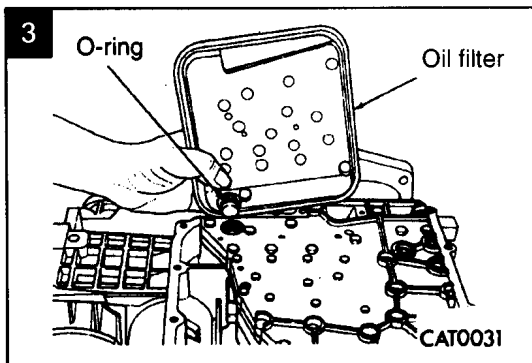
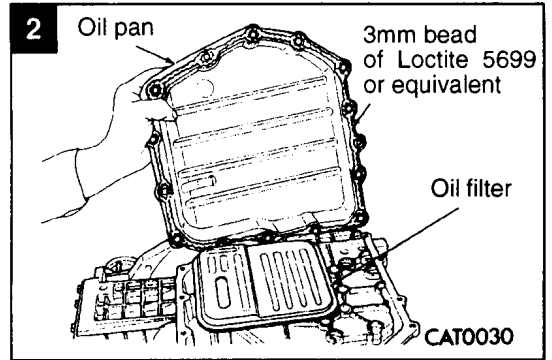
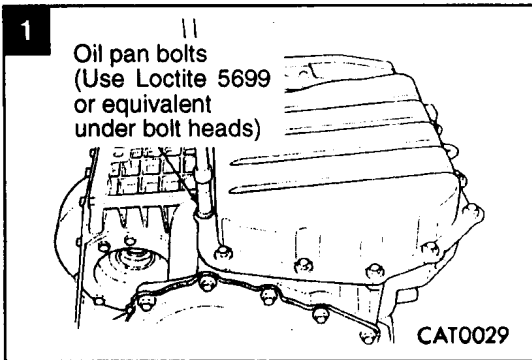

23C-3-2 AUTOMATIC TRANSMISSION – Transmission–Recondition

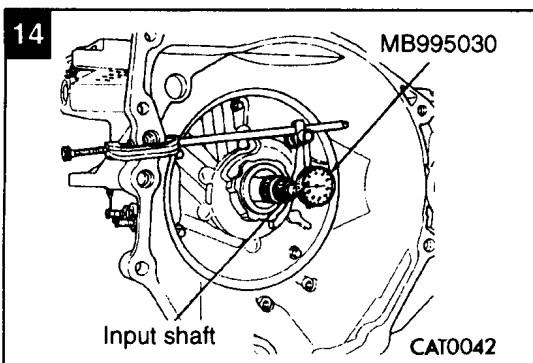
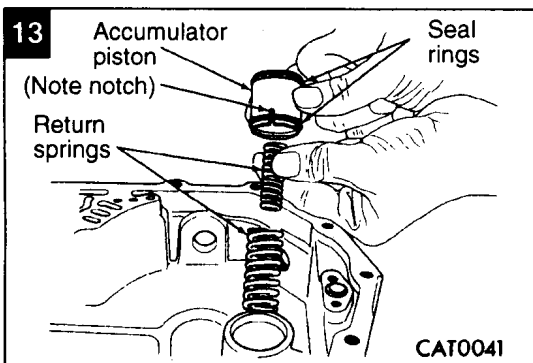
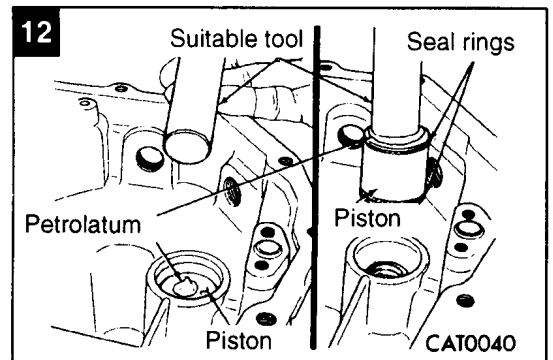
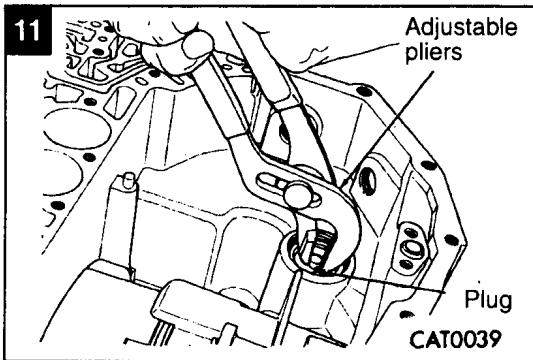
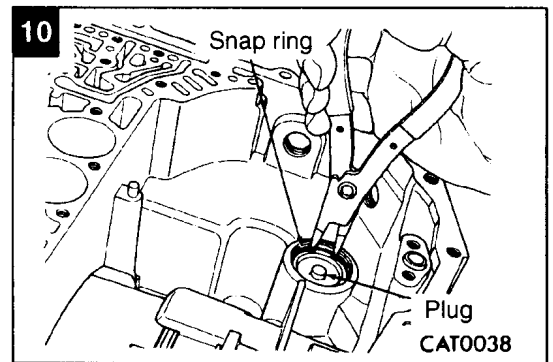
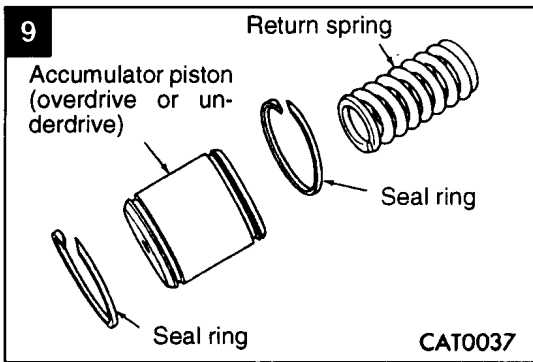

Measuring input shaft end play before disassembly will usually indicate when a No.4 thrust plate change is required (unless major parts are replaced). The No.4 thrust plate is located behind the overdrive clutch hub.

Attach a MB995030 to transmission bell-housing with its plunger seated against end of input shaft.

Move input shaft in and out to obtain end play reading.

End play specifications are 0.13 to 0.64 mm. Record indicator reading for reference when reassembling the transmission.

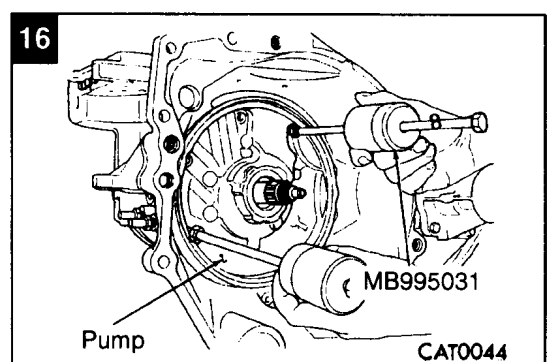
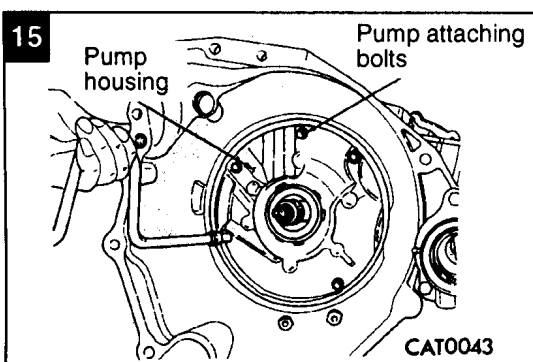

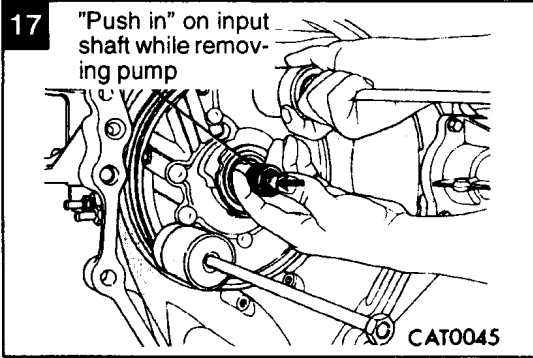

Caution

- Remove input speed sensor before removing oil pump.

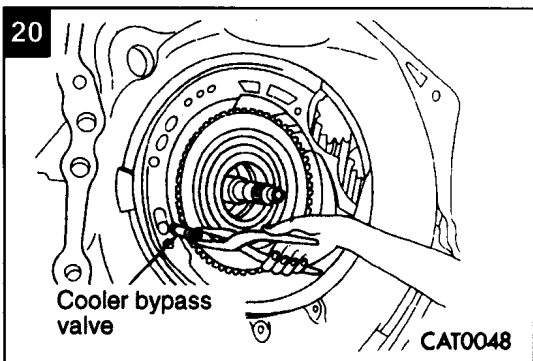
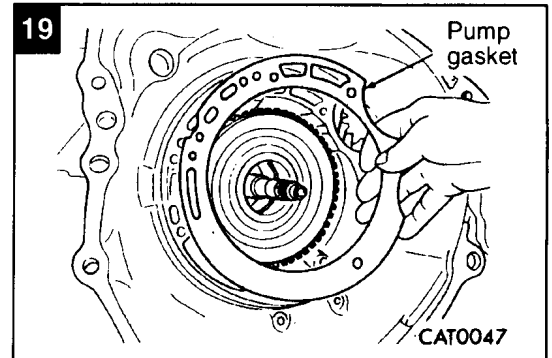
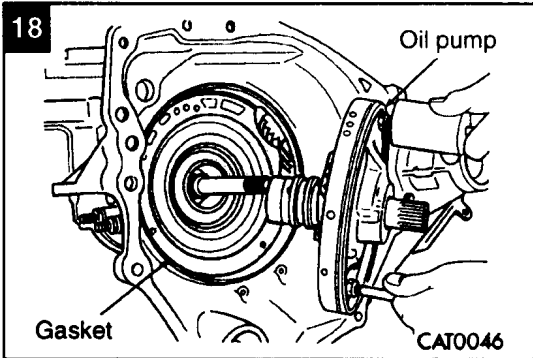

Caution

- The cooler bypass valve must be replaced if a transmission failure has occurred. Do not reuse old valve or attempt to clean old valve. When installing bypass valve, insert with O-ring end toward rear of case.

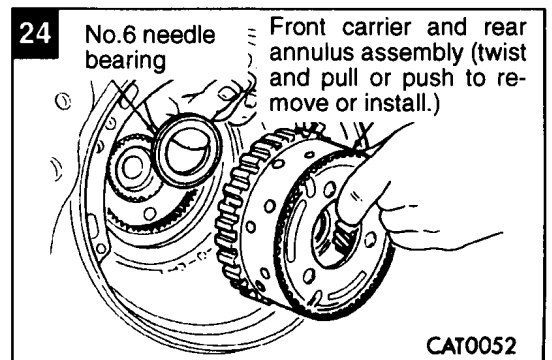
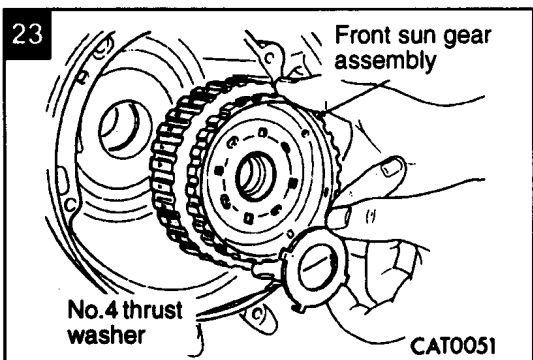
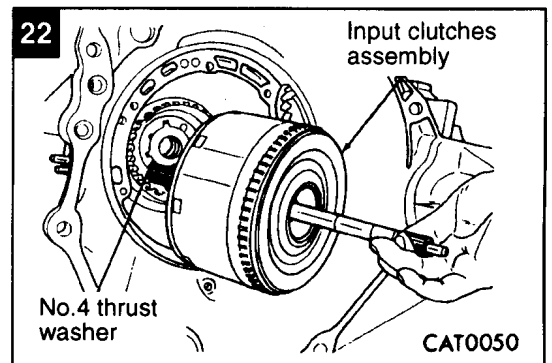
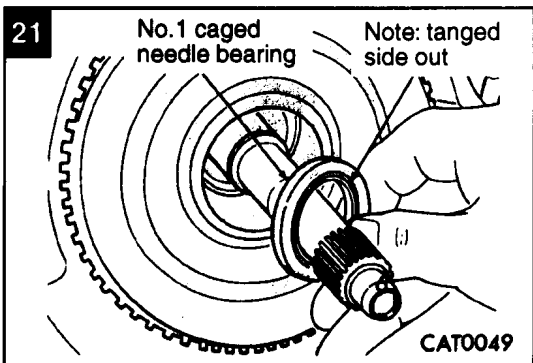

23C-3-4 AUTOMATIC TRANSMISSION – Transmission–Recondition

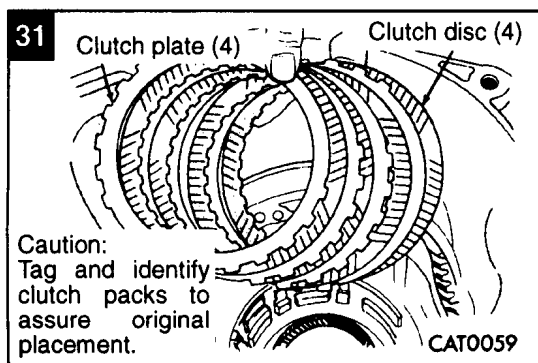
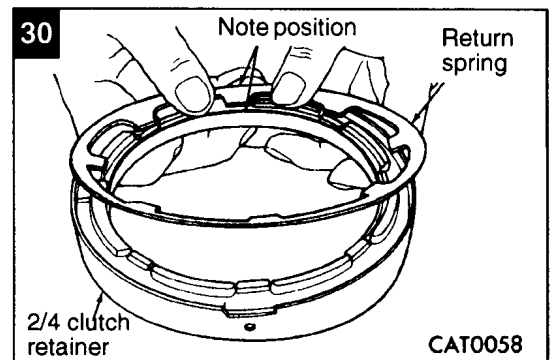
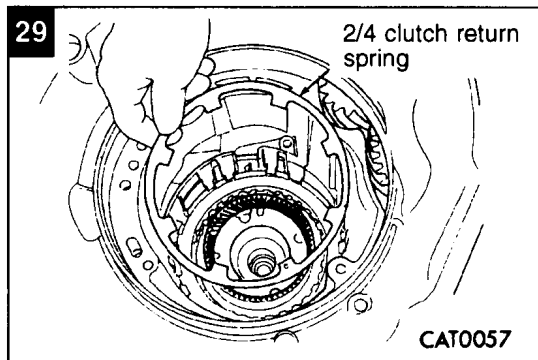
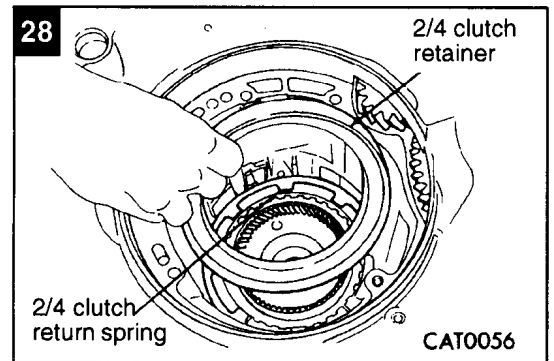
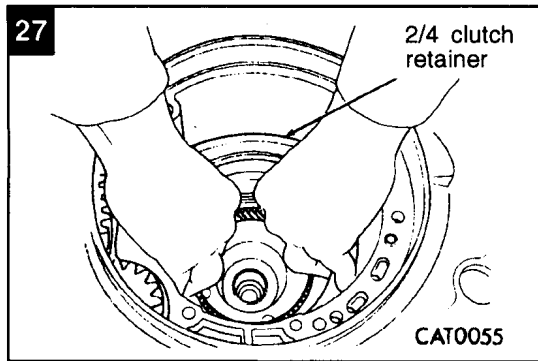
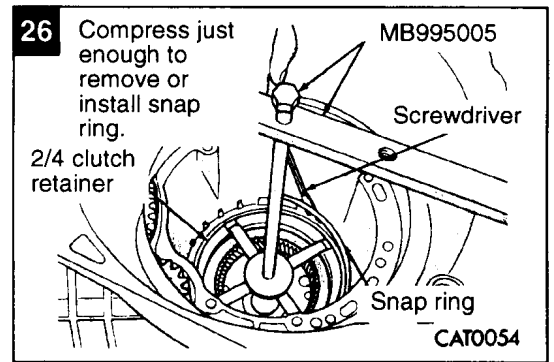
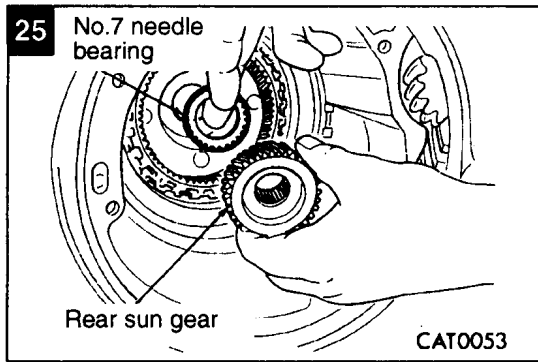

Tag 2/4 clutch pack for reassembly identification.

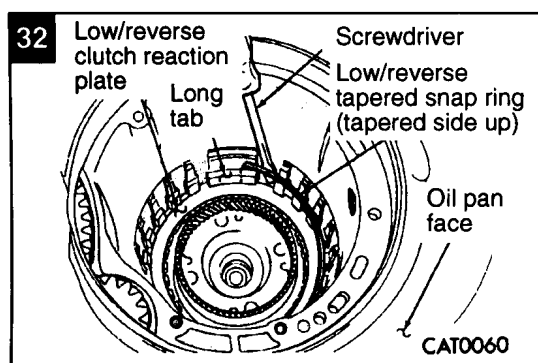

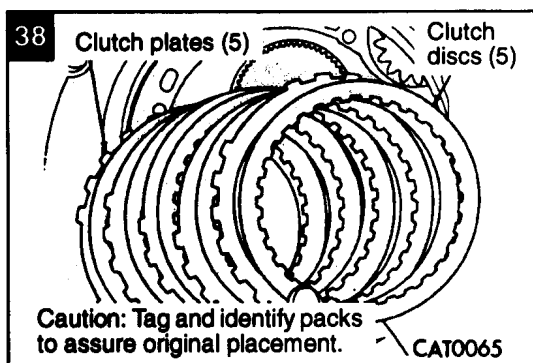
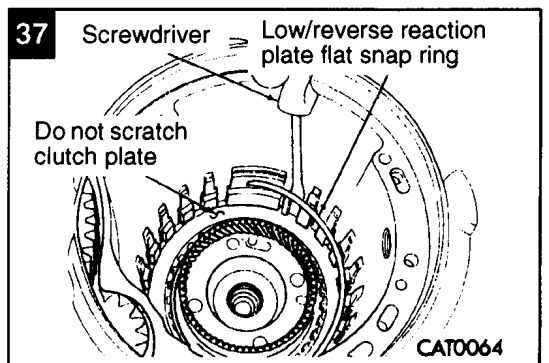
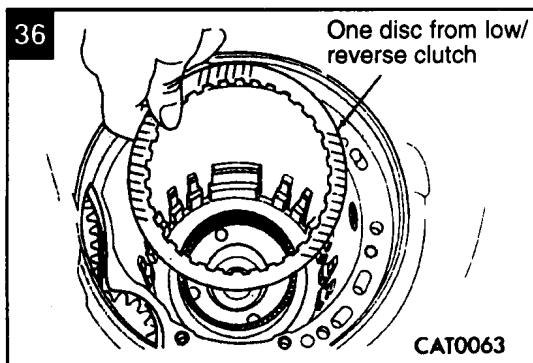
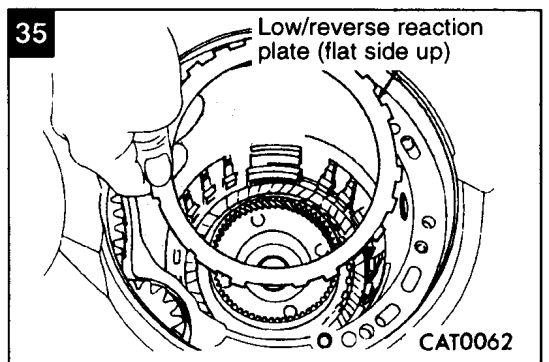
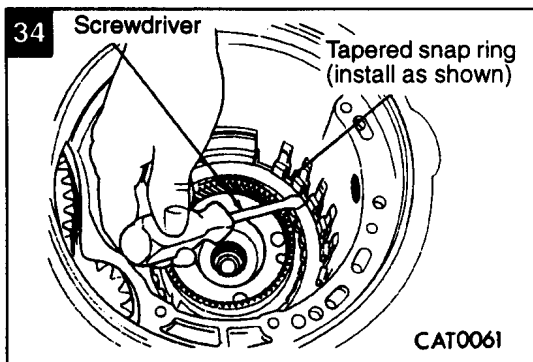
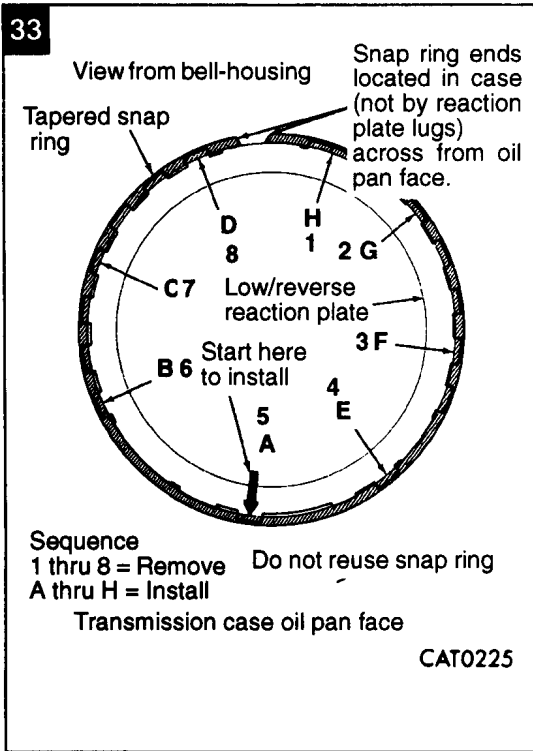

Tag low/reverse clutch pack for reassembly identification.

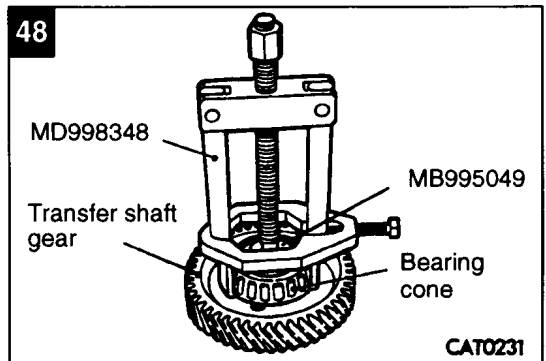
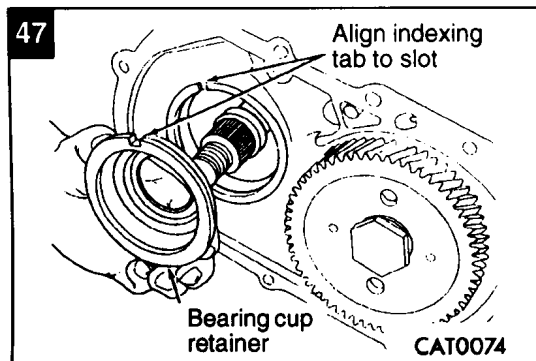
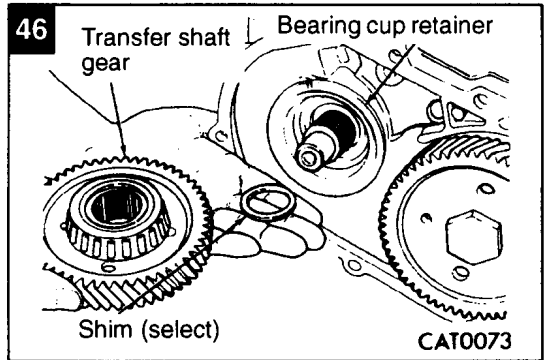
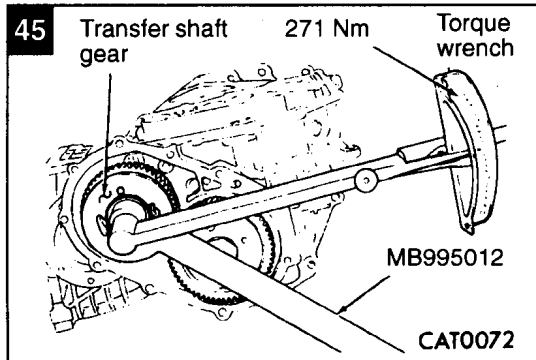
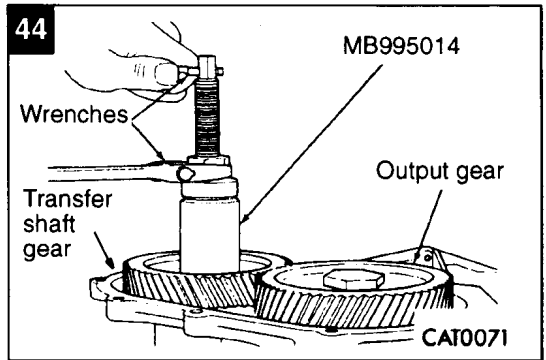
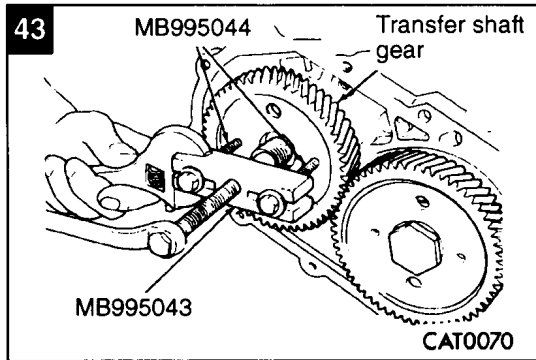
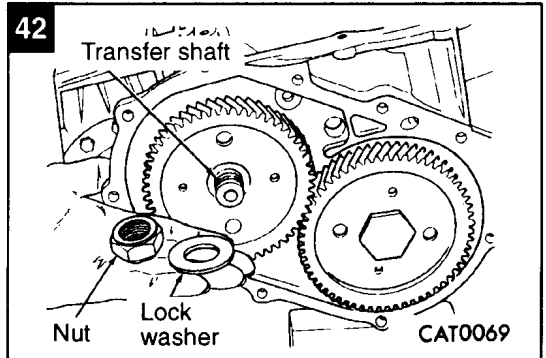
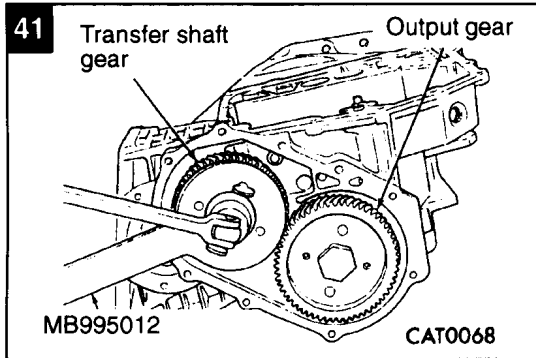
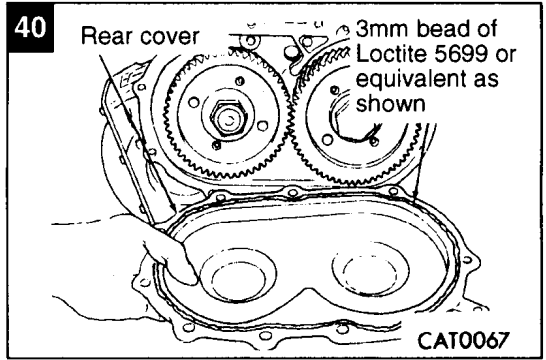
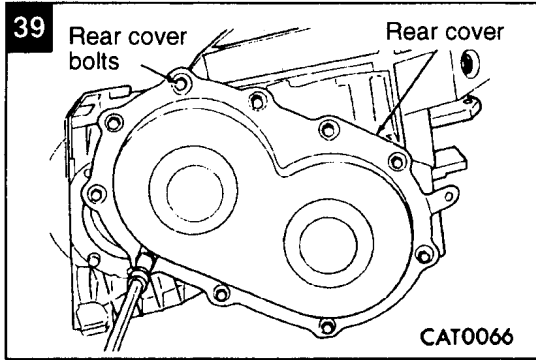

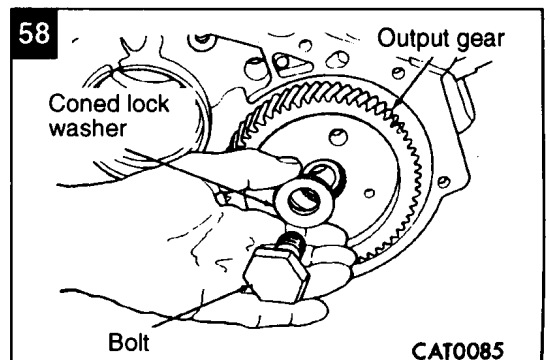
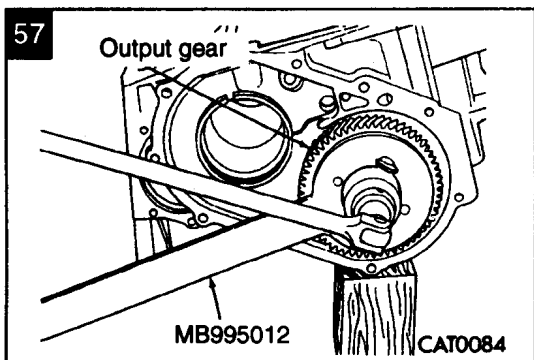
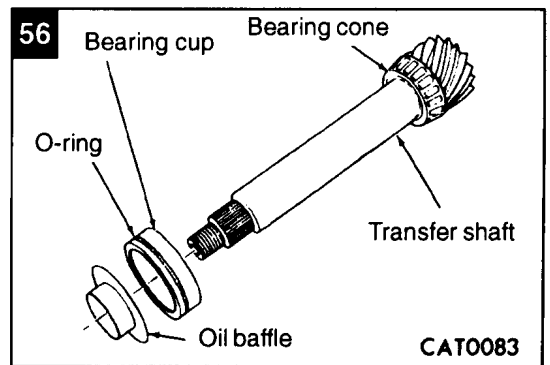
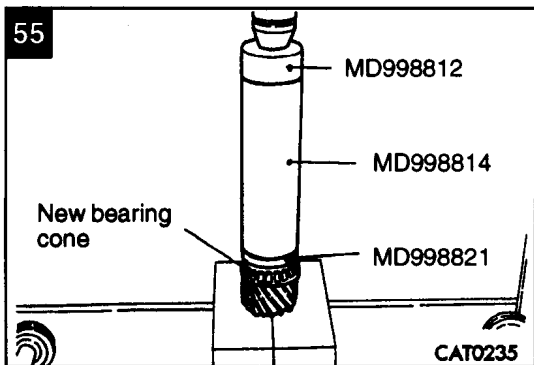
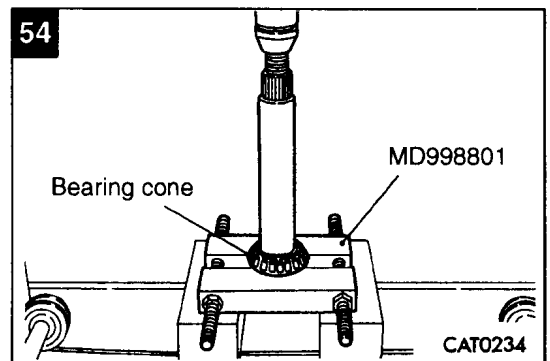
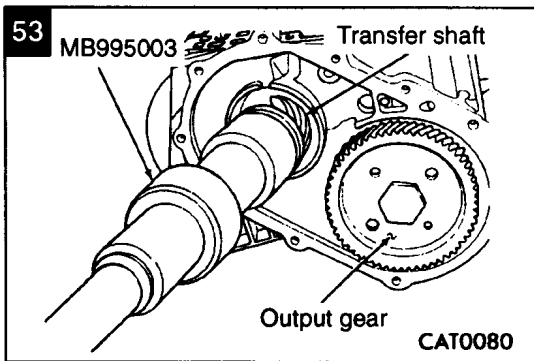
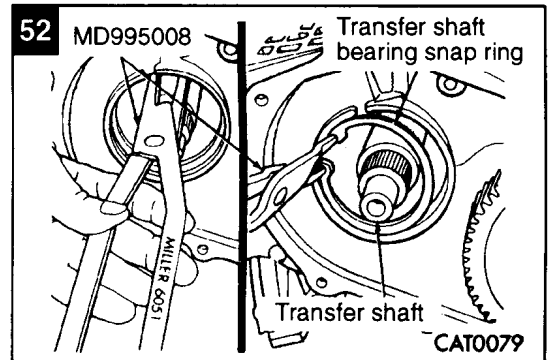
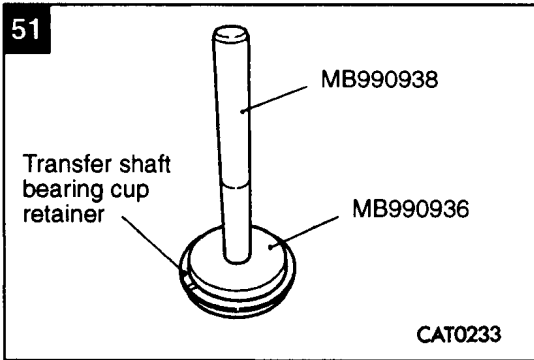
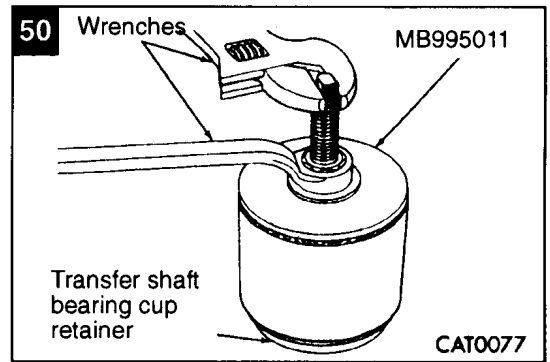
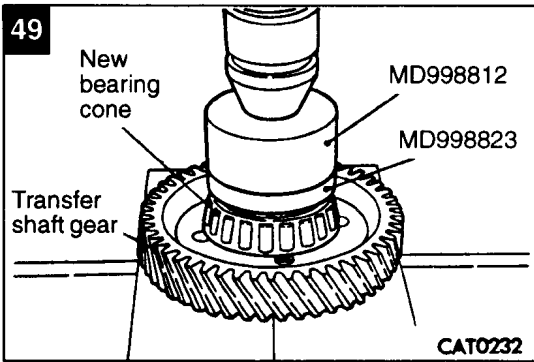

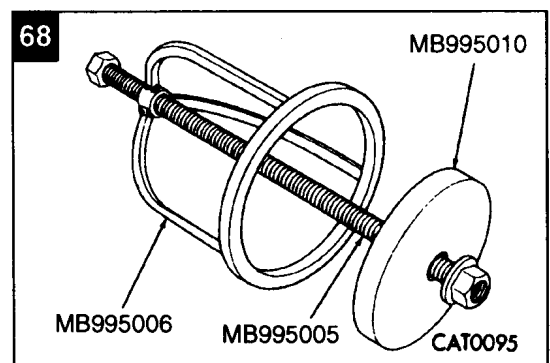
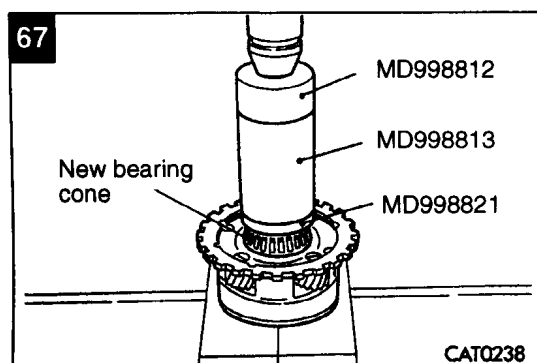
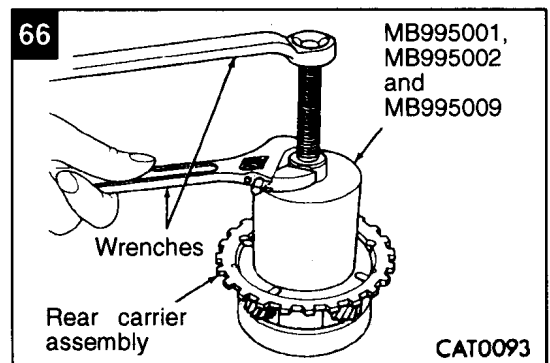
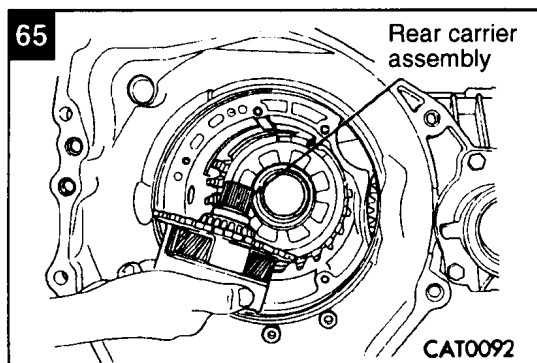
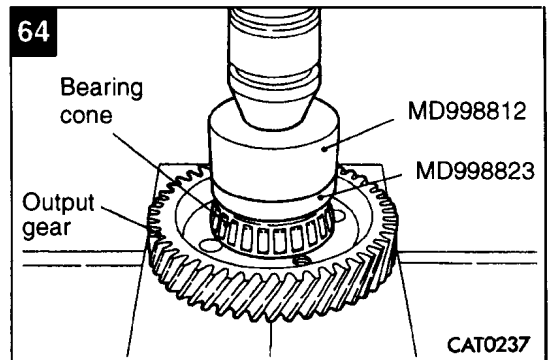
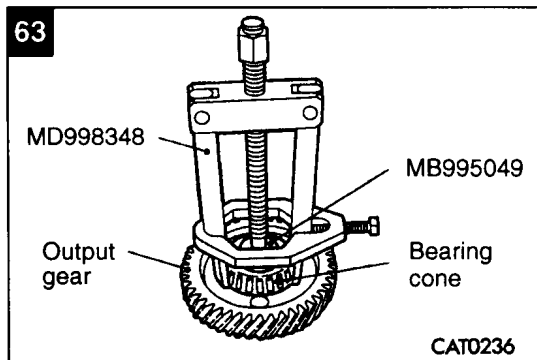
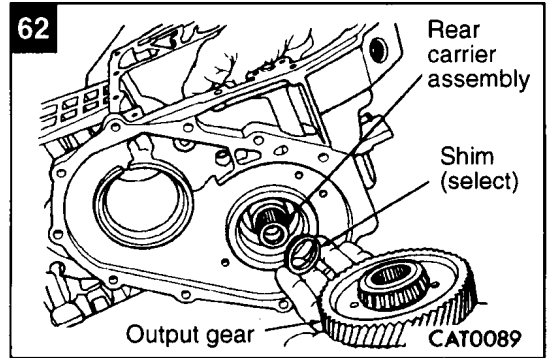
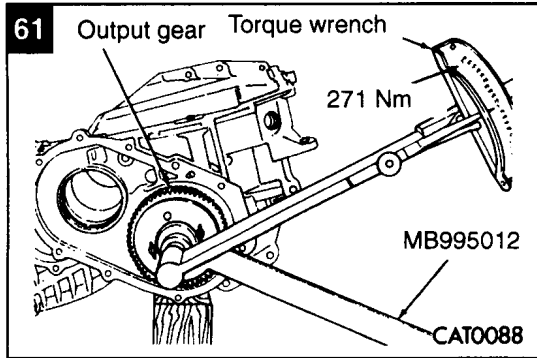
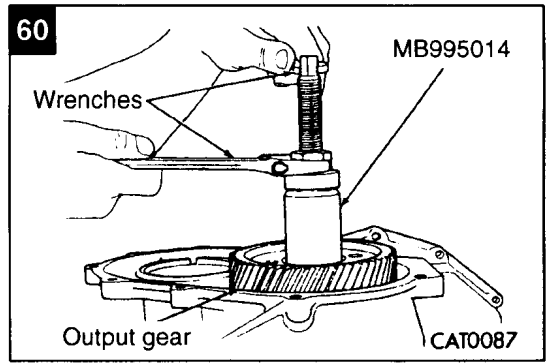
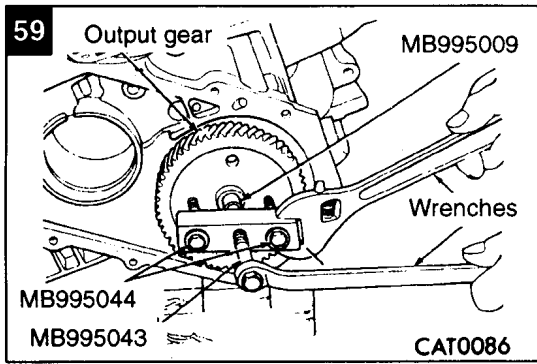

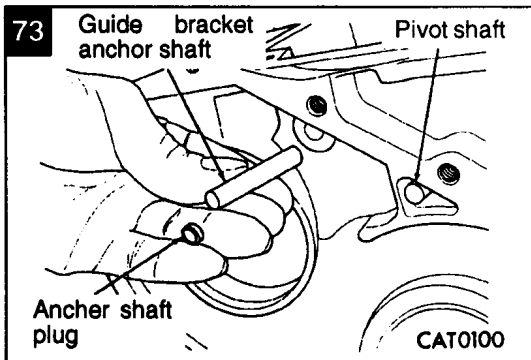
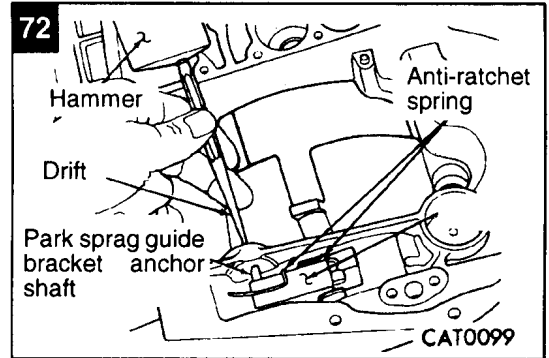
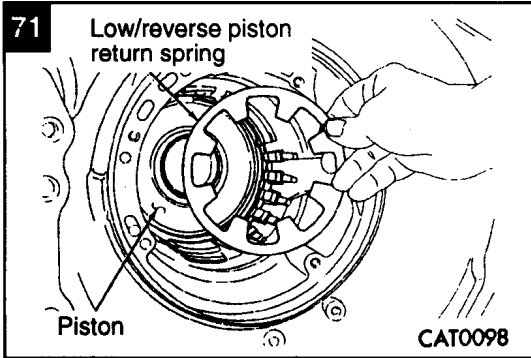
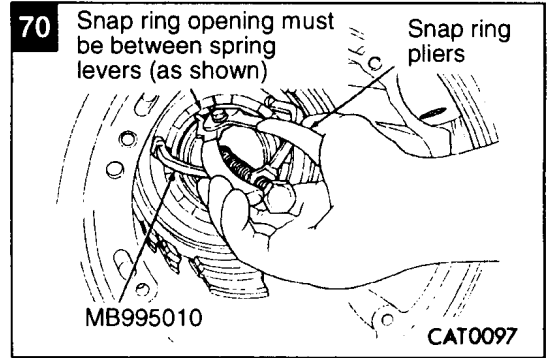
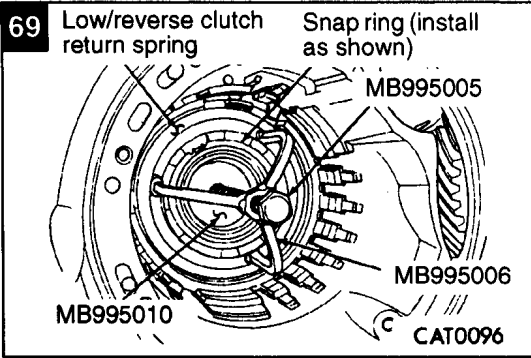

Caution

- When installing, make sure that guide bracket and split sleeve touch the rear of the transmission case.

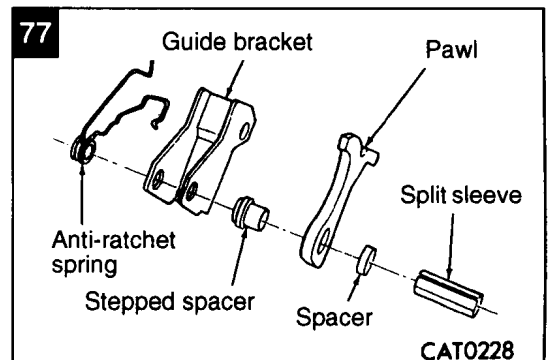
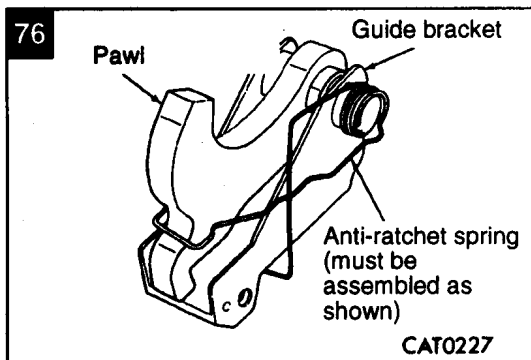
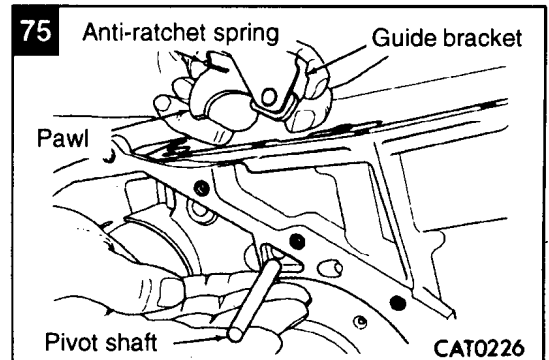
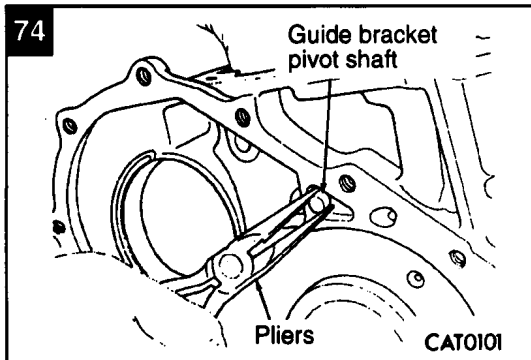

23C-3-10 AUTOMATIC TRANSMISSION – Transmission–Recondition

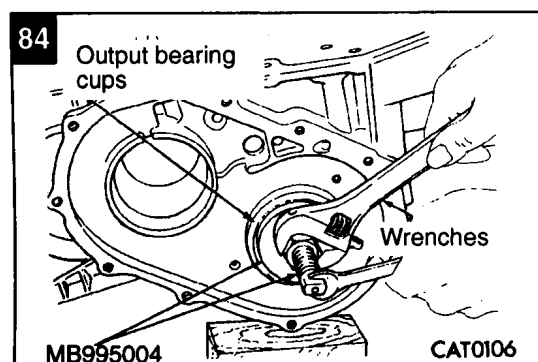
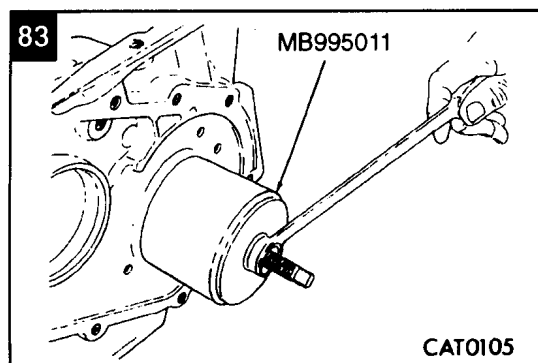
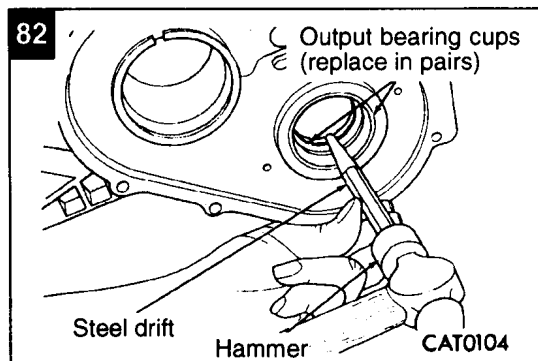
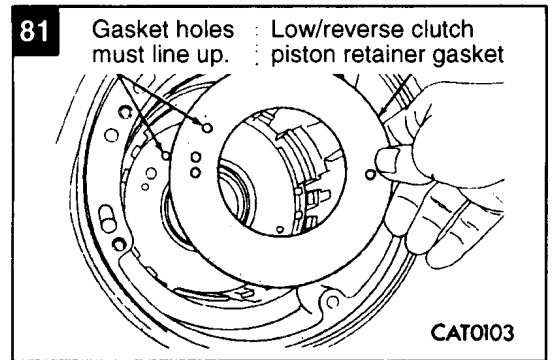
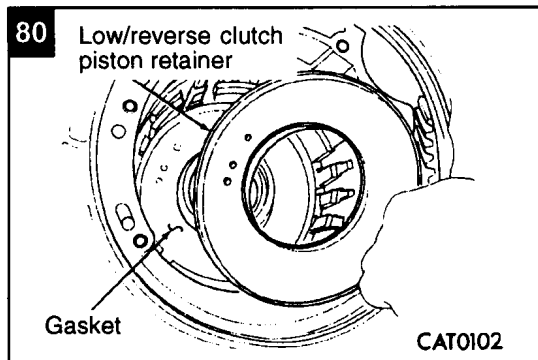
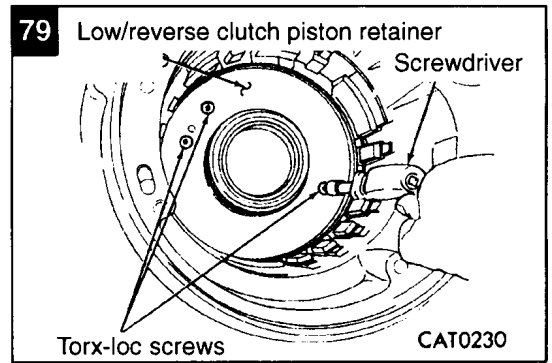
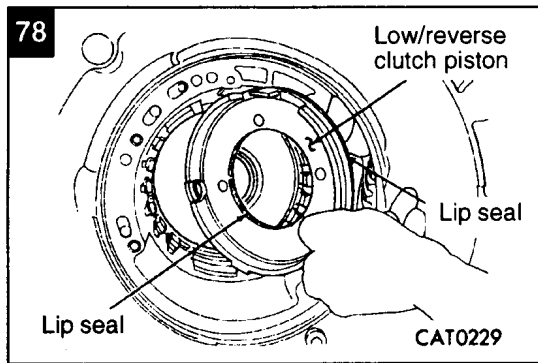

Caution

- Drift bearing cup all the way around.

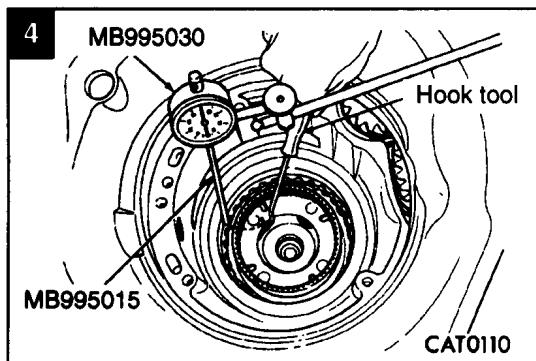
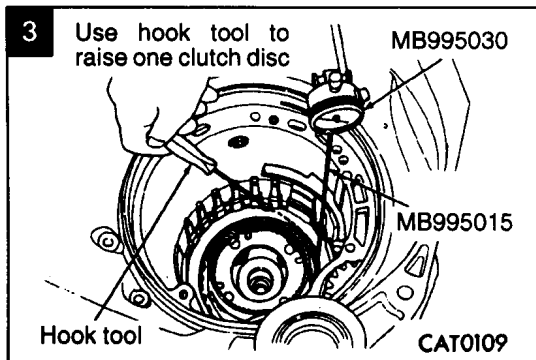
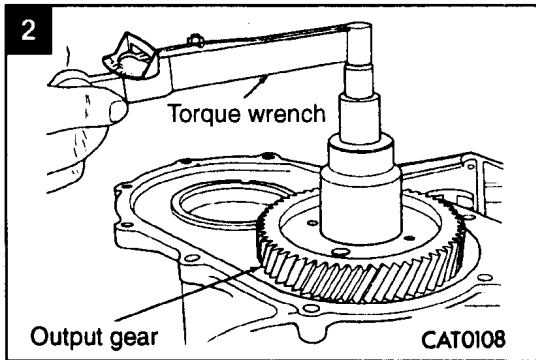
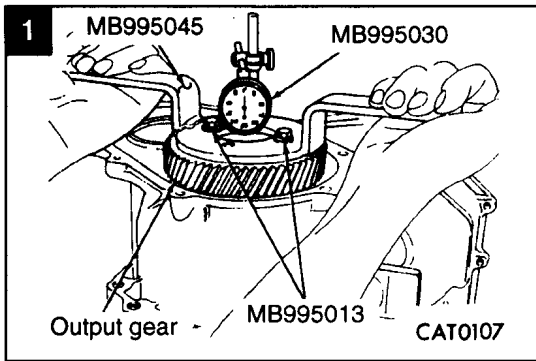

REASSEMBLY

To assemble, reverse the disassembly procedure. Be sure to check both grounded clutch clearances. Before installing the input clutches retainer, follow the instructions in determining No.4 thrust plate thickness.

Press down clutch pack with finger and zero dial indicator. Low/reverse clutch pack clearance is 1.04 to 1.65 mm.

Select the proper low/reverse reaction plate to achieve specifications:

Thickness	
6.92 mm	5.88 mm
6.66 mm	5.62 mm
6.40 mm	5.36 mm
6.14 mm	

Press down clutch pack with finger and zero dial indicator. The 2/4 clutch pack clearance is 0.76 to 2.46 mm. If not within specifications, the clutch is not assembled properly. There is no adjustment for the 2/4 clutch clearance.

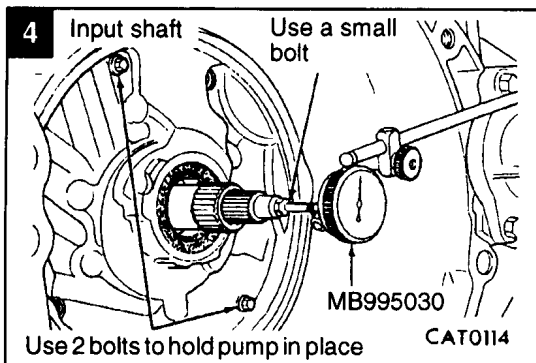
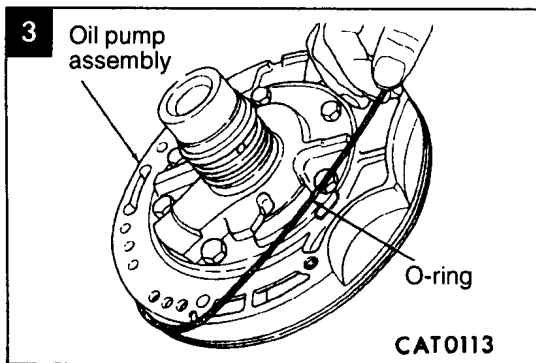
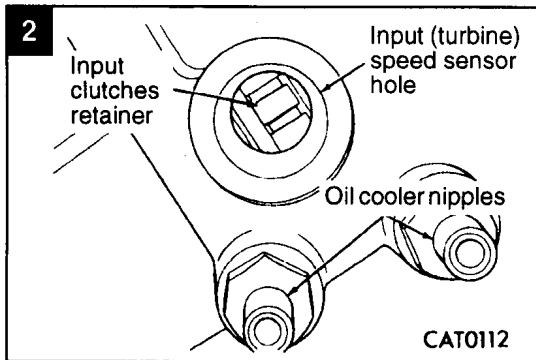
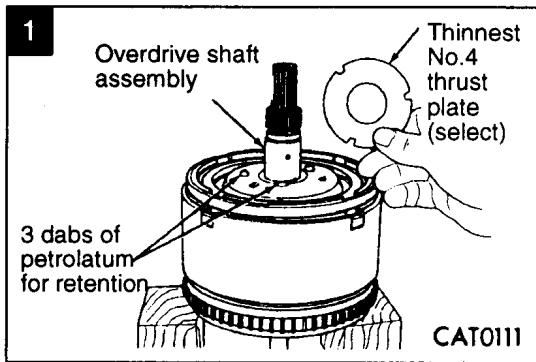

DETERMINING No.4 THRUST PLATE THICKNESS; INPUT SHAFT END PLAY

Determine according to illustration numbers. To determine the proper thickness of the No.4 thrust plate, select the thinnest No.4 thrust plate. Using petrolatum to hold thrust plate in position, install input clutches assembly. Be sure the input clutches assembly is completely seated.

Caution

- If view through input speed sensor hole is not as shown above, the input clutches assembly is not seated properly.

By removing the oil pump O-ring, you will be able to install and remove the oil pump and gasket very easily. This aids selection of the No.4 thrust plate.

Caution

- Be sure to reinstall O-ring on oil pump after selecting the proper No.4 thrust plate.

Input shaft end play must be 0.13 to 0.064 mm. For example, if end play reading is 1.4 mm, select No.4 thrust plate which is 1.8 to 1.9 mm thick. This should provide an input shaft end play reading of 0.51 mm which is within specifications.

See chart below to select the proper No.4 thrust plate.

No.4 THRUST PLATE CHART

Shim thickness
mm
0.81–1.03
1.03–1.25
1.25–1.47
1.47–1.69
1.69–1.91
1.91–2.13
2.13–2.35
2.35–2.57
2.57–2.79
2.79–3.01
3.01–3.23
3.23–3.45

4. INPUT CLUTCHES–RECONDITION

DISASSEMBLY

Disassemble according to illustration numbers.

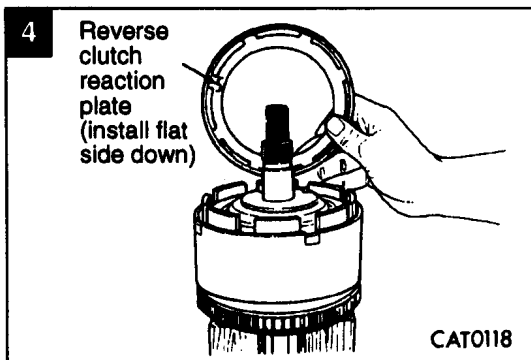
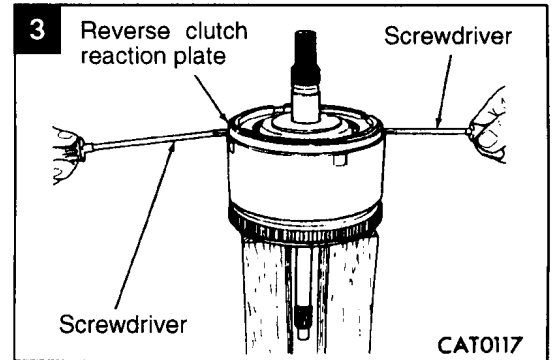
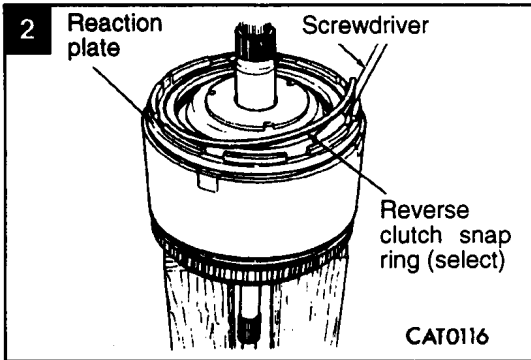
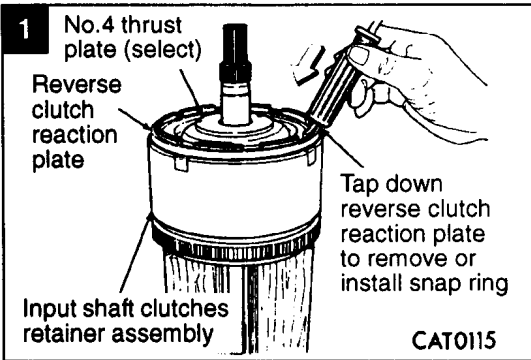

Tag reverse clutch pack for reassembly identification.

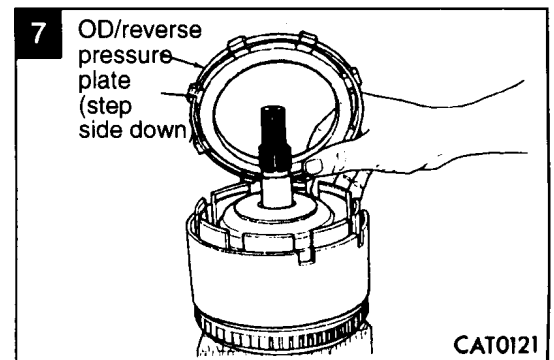
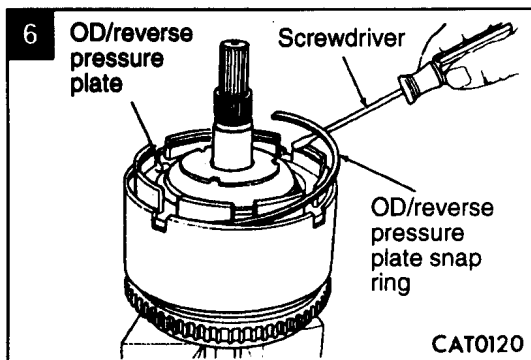
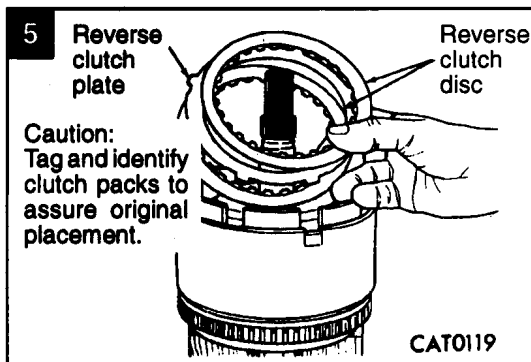

23C-4-2 AUTOMATIC TRANSMISSION – Input Clutches–Recondition

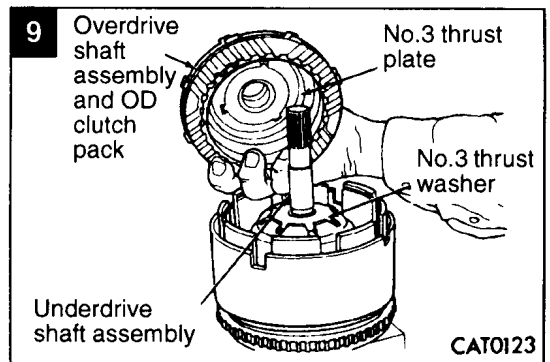
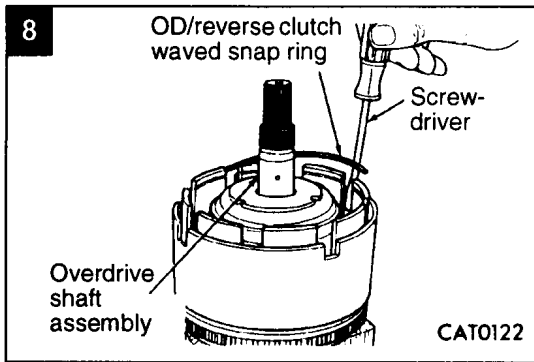

Tag overdrive clutch pack for reassembly identification.

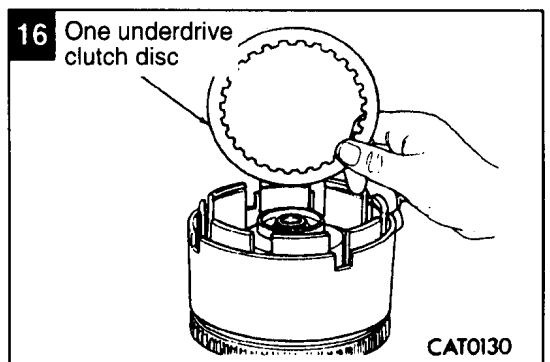
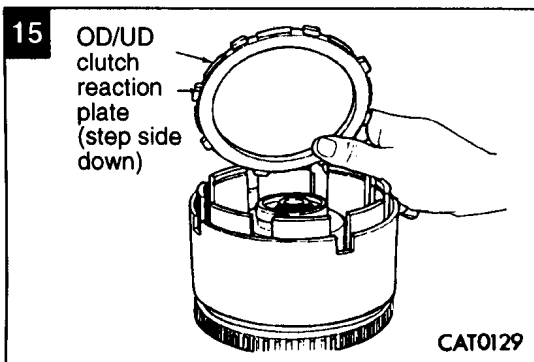
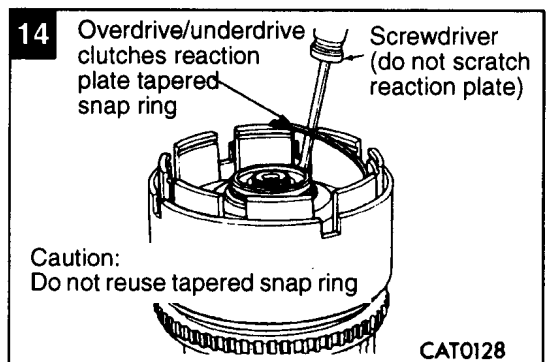
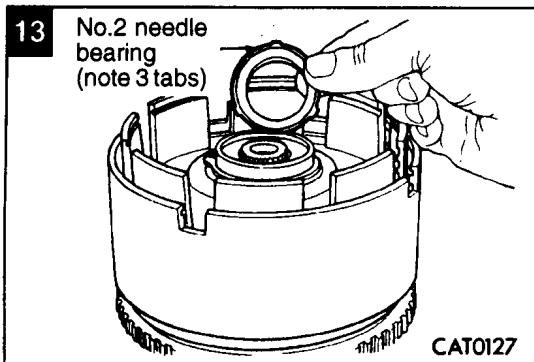
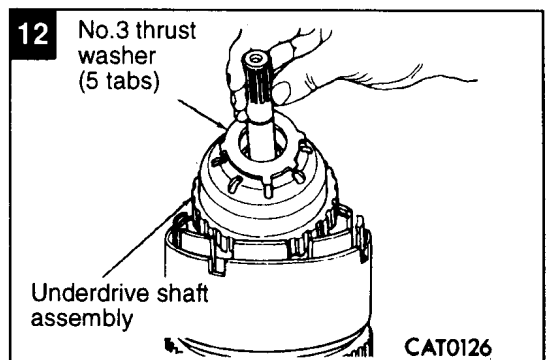
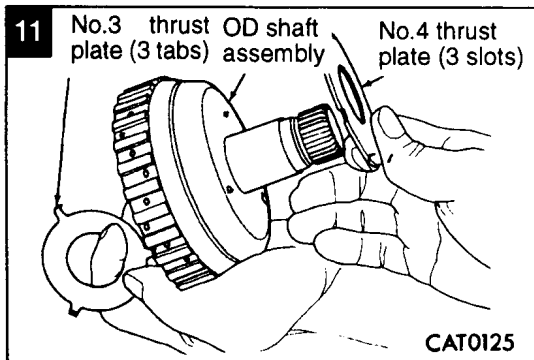
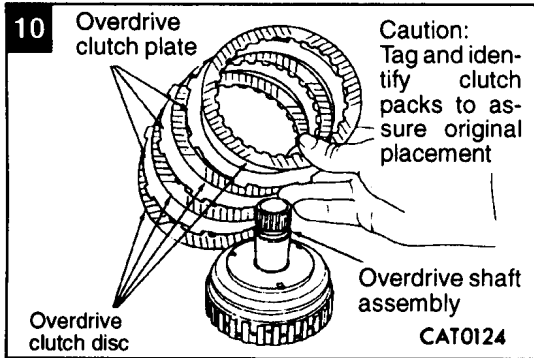

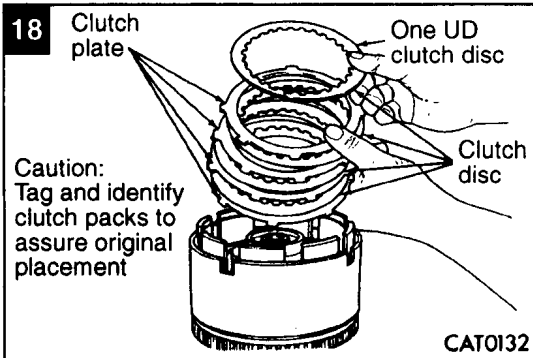
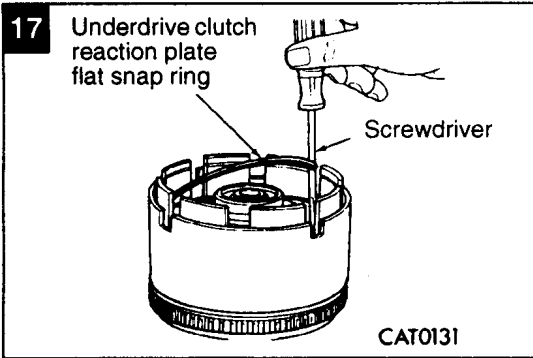

Tag underdrive clutch pack for reassembly identification.

Caution

- Compress return spring just enough to remove or install snap ring.

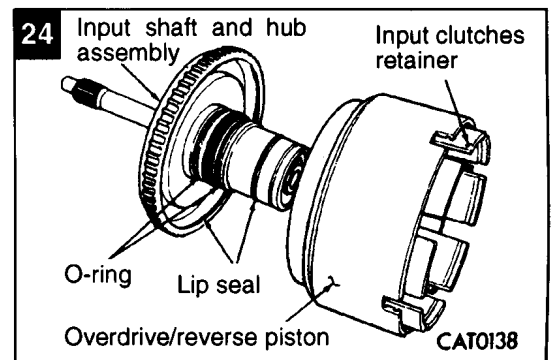
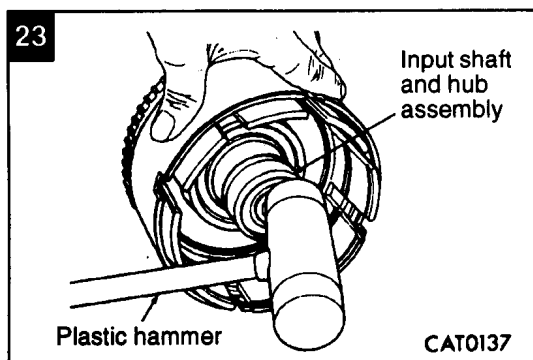
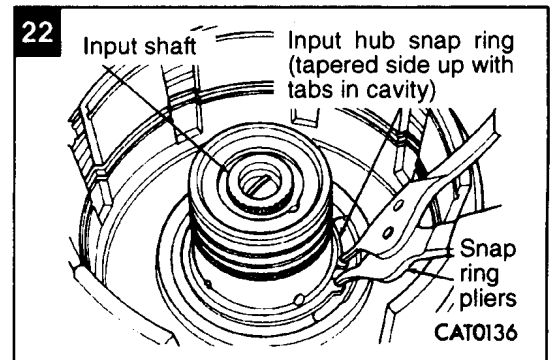
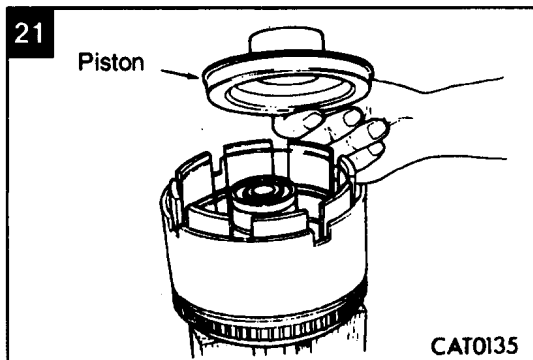
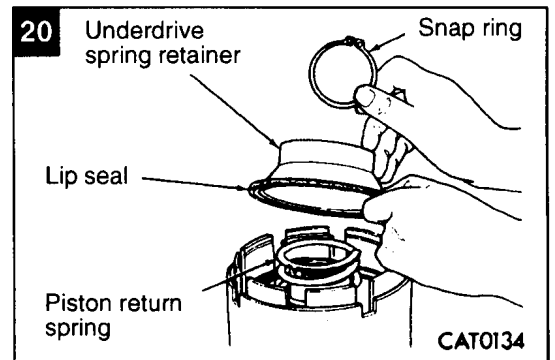
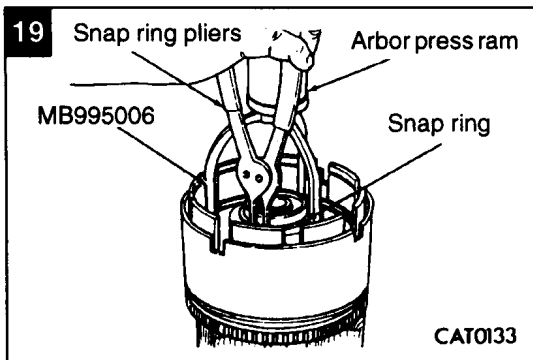

23C-4-4 AUTOMATIC TRANSMISSION – Input Clutches–Recondition

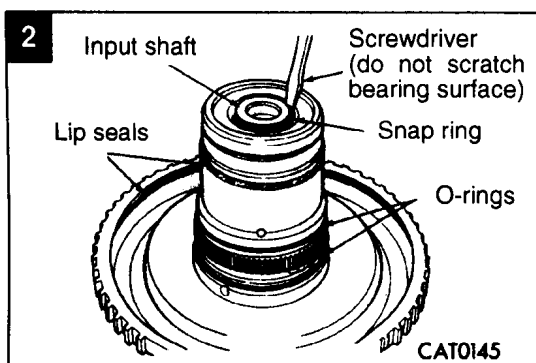
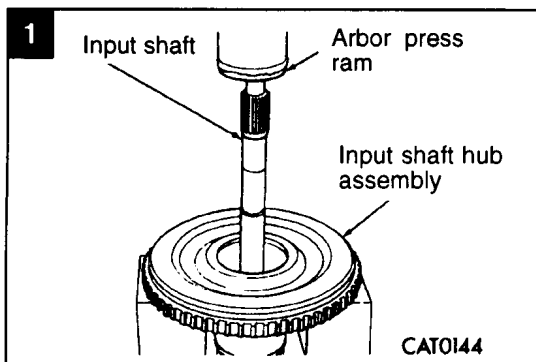
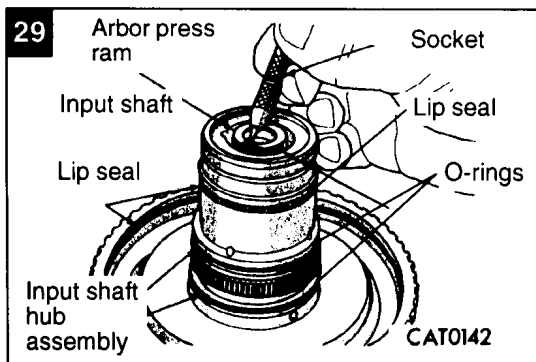
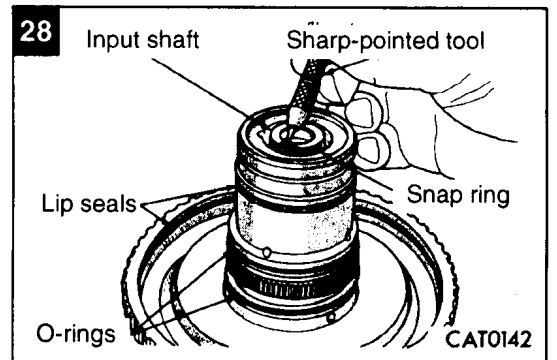
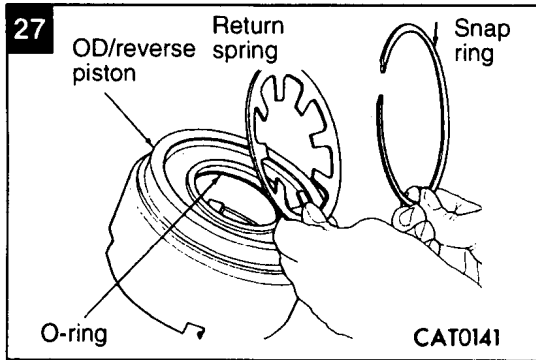
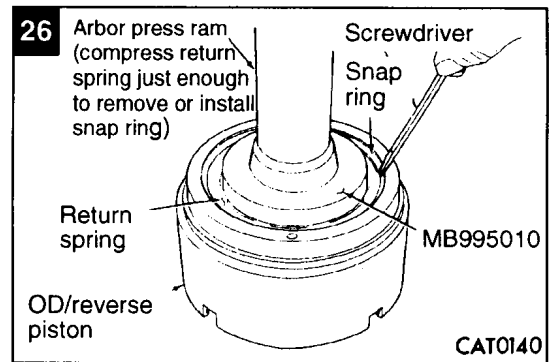
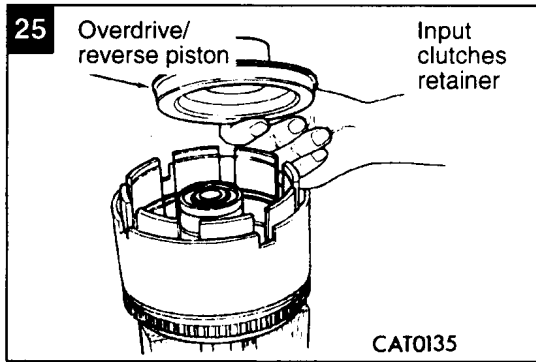

REASSEMBLY

N23ZG08AB

Assemble according to illustration numbers.
Use petrolatum on all seals to ease assembly of component.

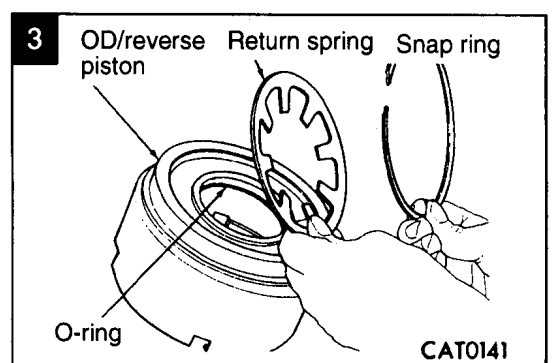

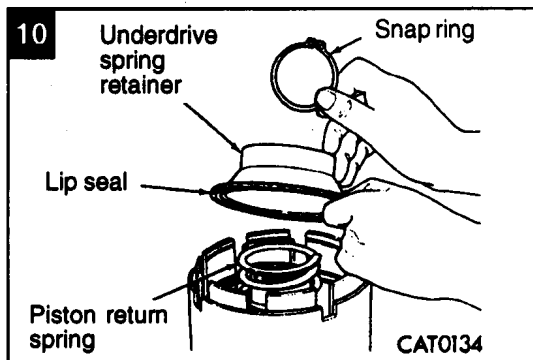
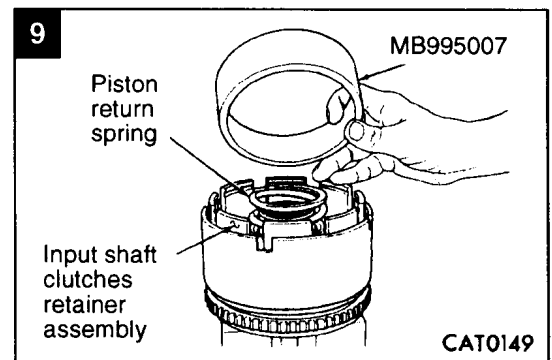
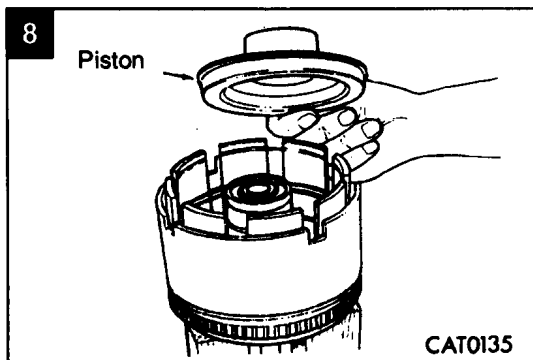
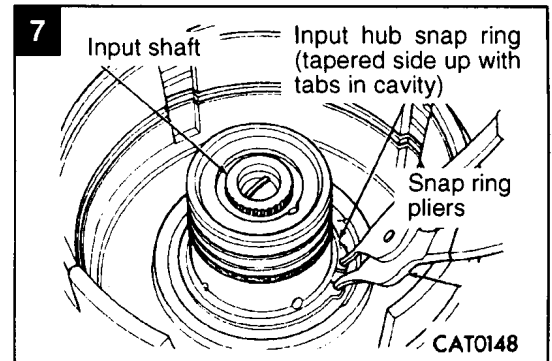
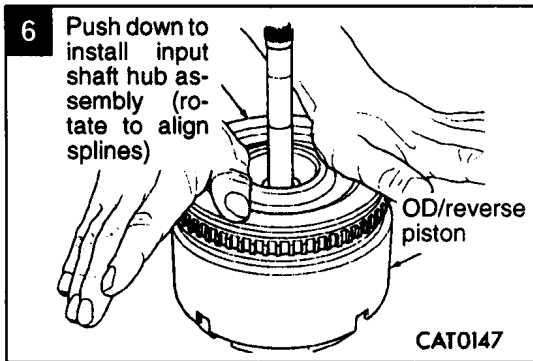
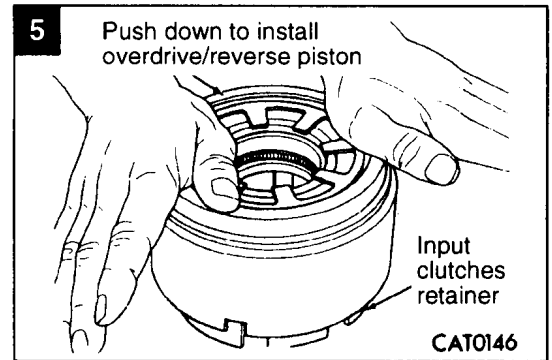
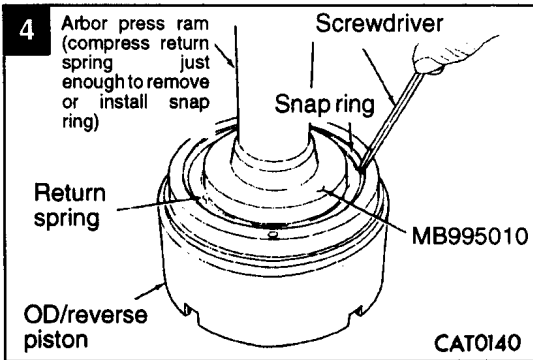

Caution

- Compress return spring just enough to remove or install snap ring.

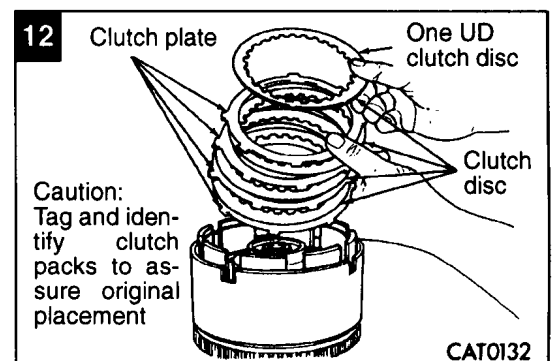
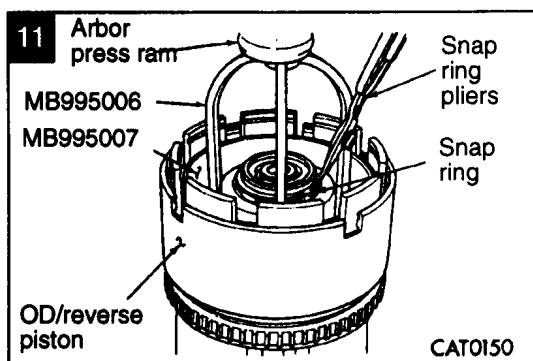

Caution:
Tag and identify clutch packs to assure original placement

23C-4-6 AUTOMATIC TRANSMISSION – Input Clutches–Recondition

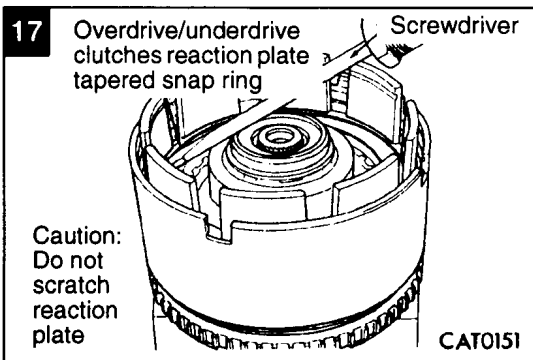
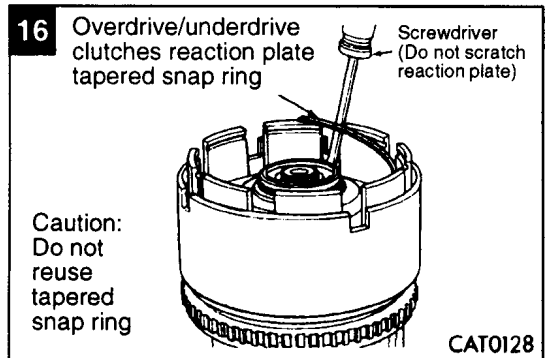
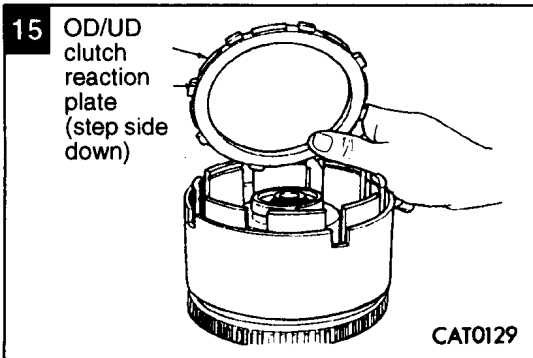
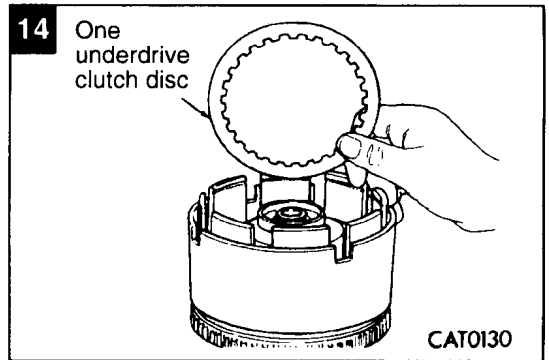
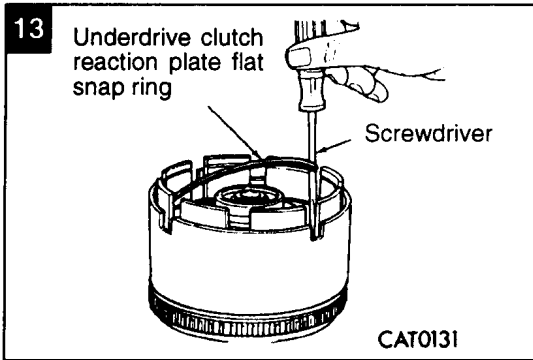

Snap ring ends must be located within one finger of the input clutch hub. Be sure that snap ring is fully seated, by pushing with screwdriver, into snap ring groove all the way around.

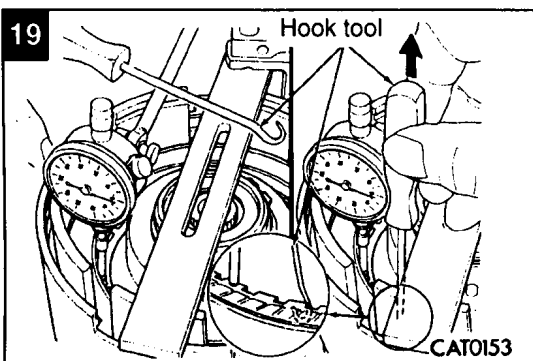
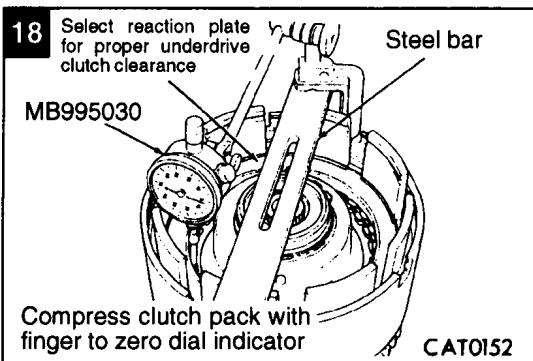

UNDERDRIVE REACTION PLATE CHART

Thickness
6.99 mm
6.50 mm
6.01 mm
5.52 mm

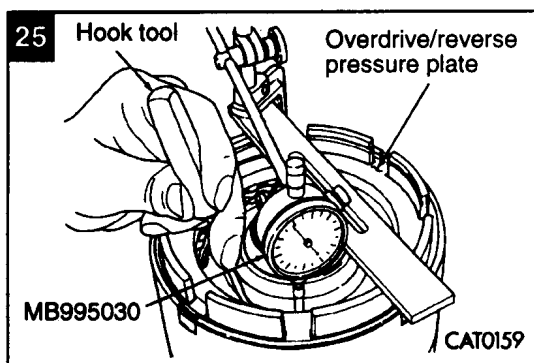
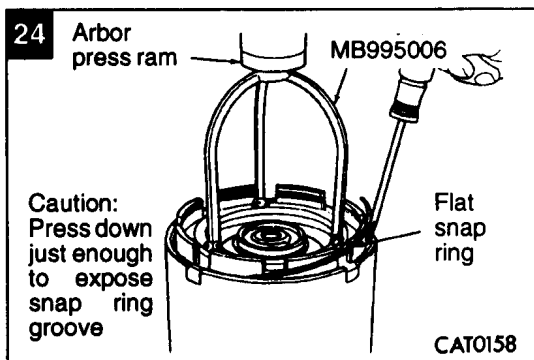
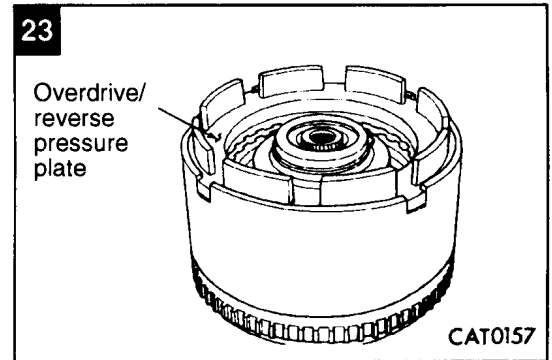
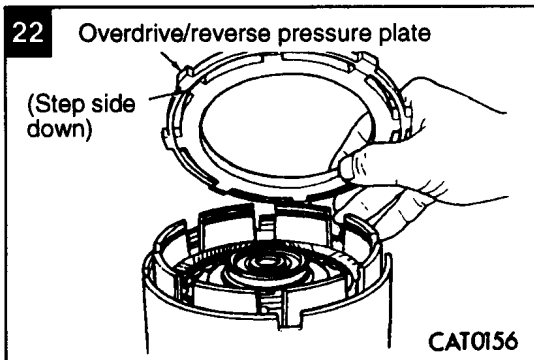
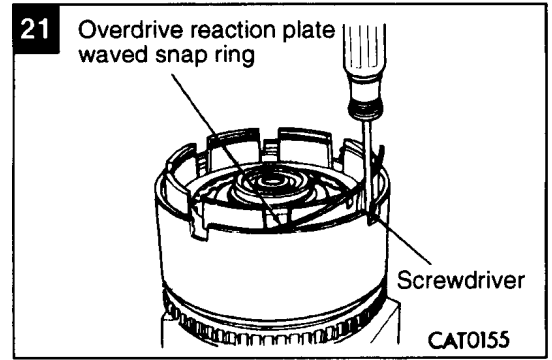
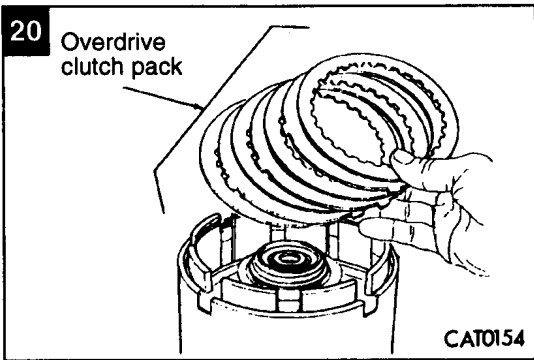

The overdrive (OD) clutch pack clearance is 1.07 to 2.44 mm. If not within specifications, the clutch is not assembled properly. There is no adjustment for the OD clutch clearance.

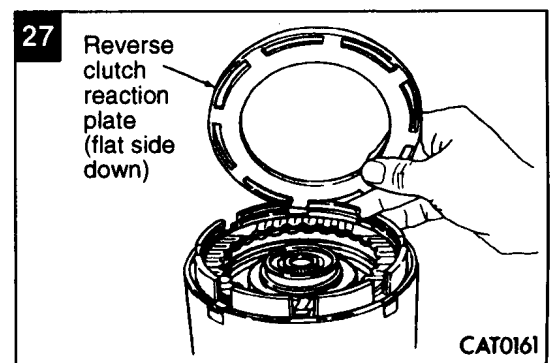
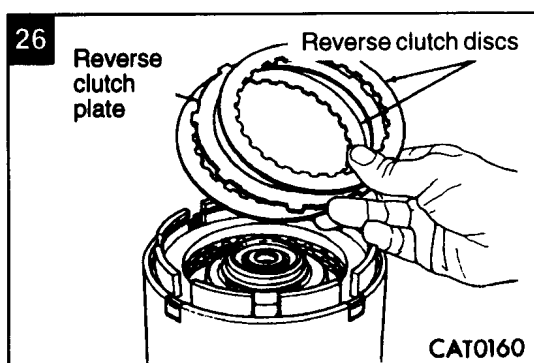

23C-4-8 AUTOMATIC TRANSMISSION – Input Clutches–Recondition

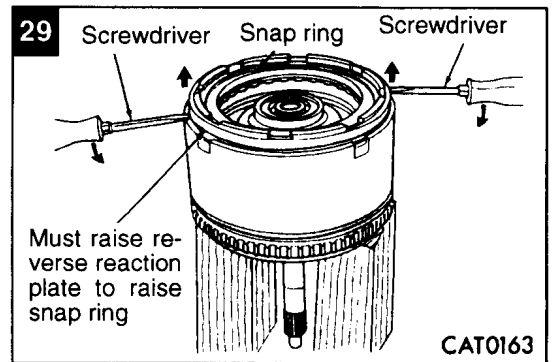
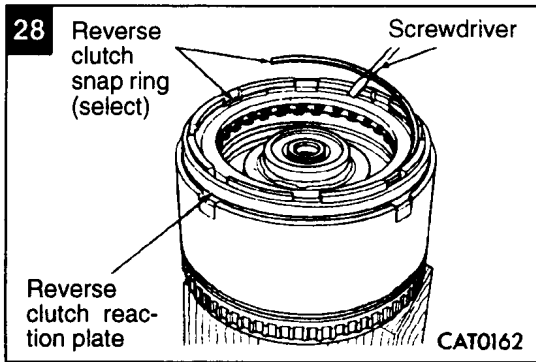

The reverse clutch pack clearance is 0.76 to 1.24 mm. Select the proper reverse clutch snap ring to achieve specifications.

Thickness
1.56 mm
1.80 mm
2.05 mm
2.30 mm

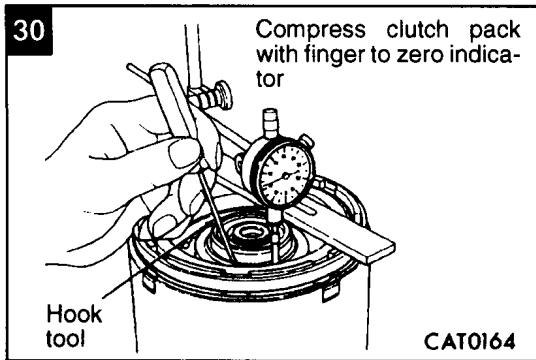

All clutch clearance in the input clutch retainer have now been checked and approved. To complete the assembly of the input clutch retainer, the reverse clutch and the overdrive clutch must be removed from the retainer.

Caution

- Do not intermix clutch parts. Keep in exact same order.
- Now proceed with the next phase of the assembly:

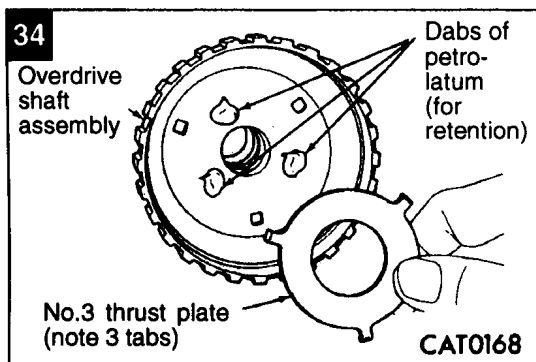
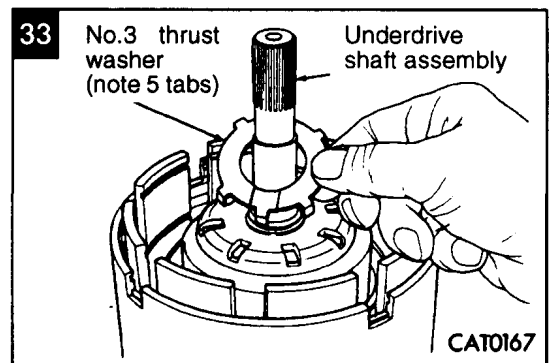
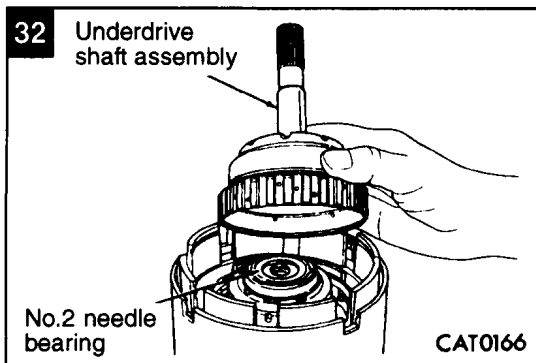
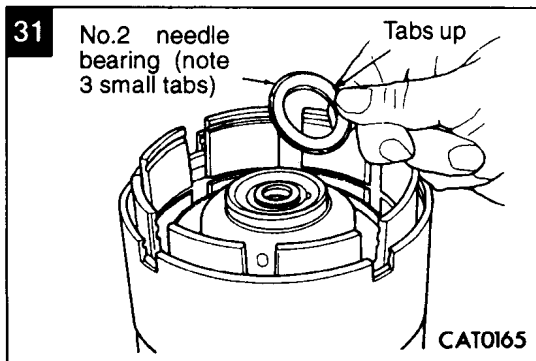

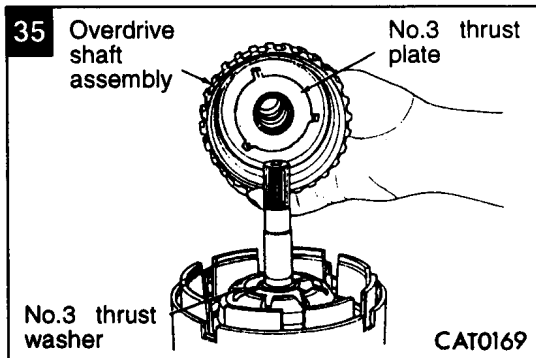

Now that both shaft assemblies and thrust washers are properly installed, reinstall overdrive clutch and reverse clutch as shown in illustration (step 20–28). Rechecking these clutch clearance is not necessary, as they were set and approved previously.

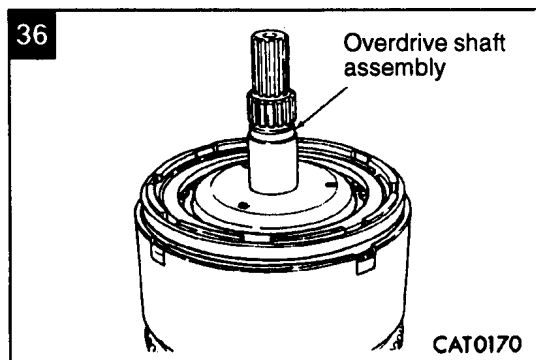

5. VALVE BODY–RECONDITION

Carry out according to illustration numbers.

Prior to removing any transmission subassemblies, plug all openings and thoroughly clean exterior of the unit, preferably by steam. Cleanliness through entire disassembly and assembly cannot be overemphasized. When disassembling, each part should be washed in a suitable solvent, then dried by compressed air. Do not wipe parts with shop towels. All mating surfaces in the transmissions are accurately machined; therefore, careful handling of all parts must be exercised to avoid nicks or burrs. Tag all springs, as they are removed, for reassembly identification.

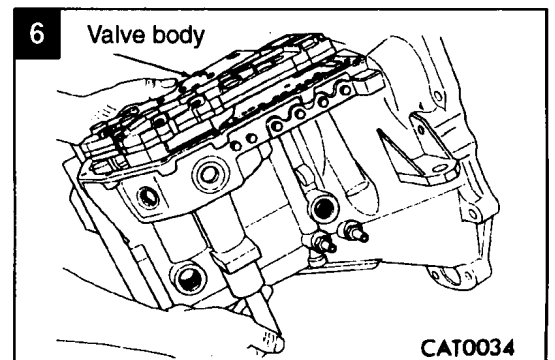
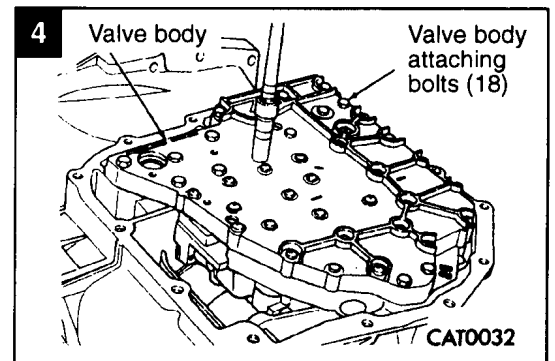
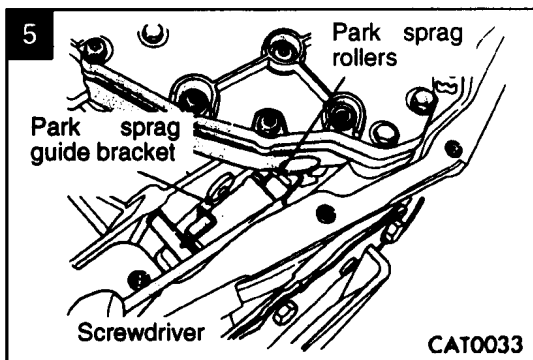
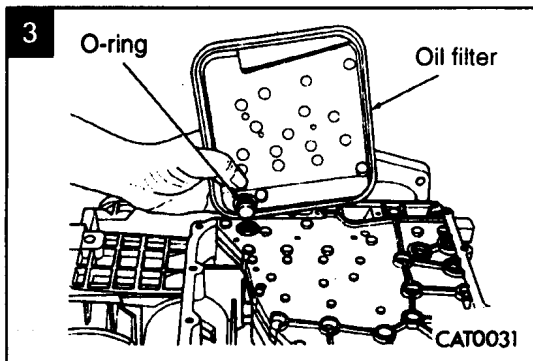
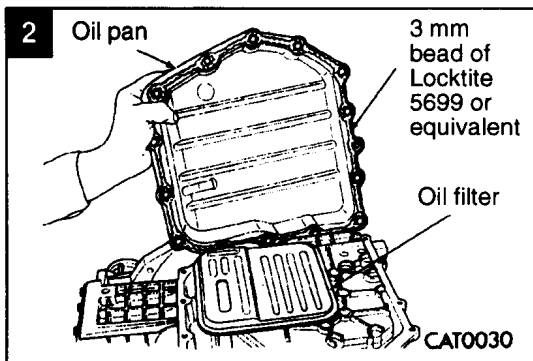
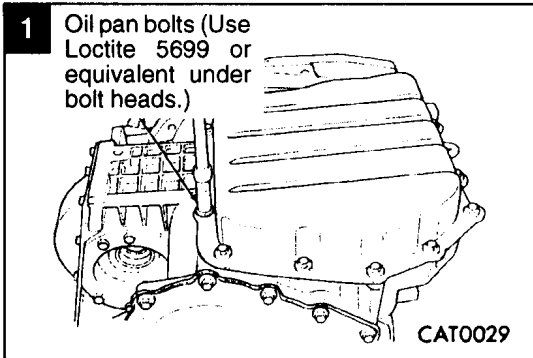

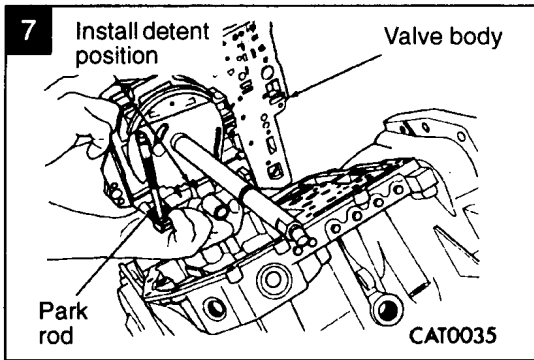

Caution

- The valve body manual shaft pilot may distort and bind the manual valve, if the valve body is mishandled or dropped.

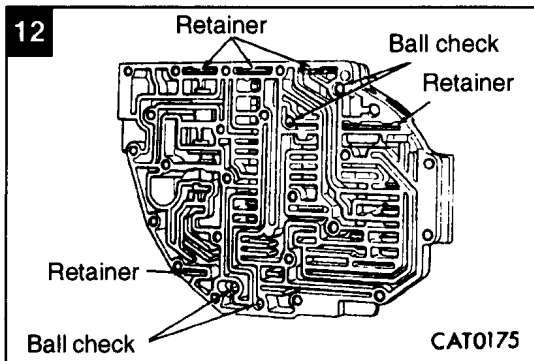
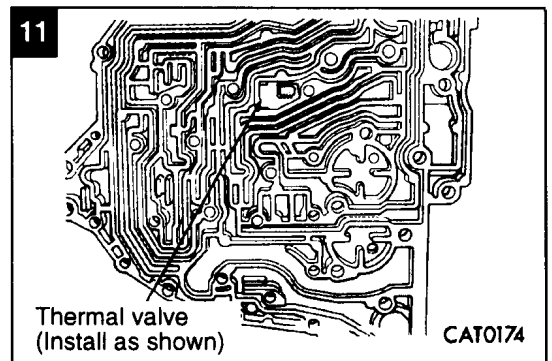
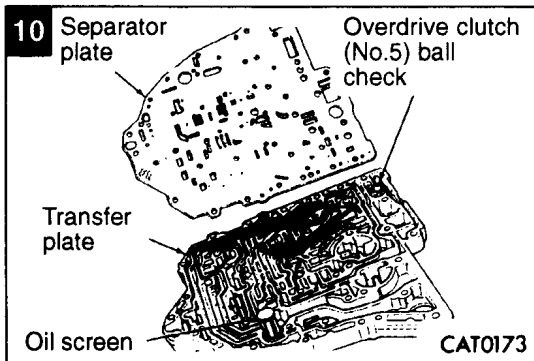
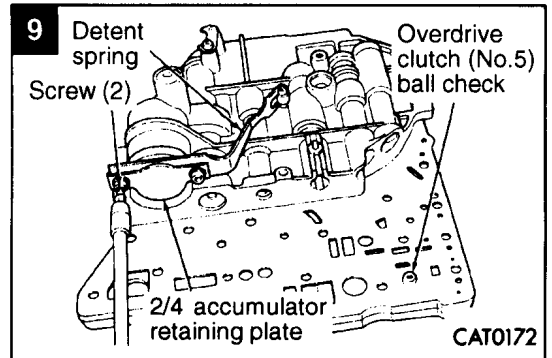
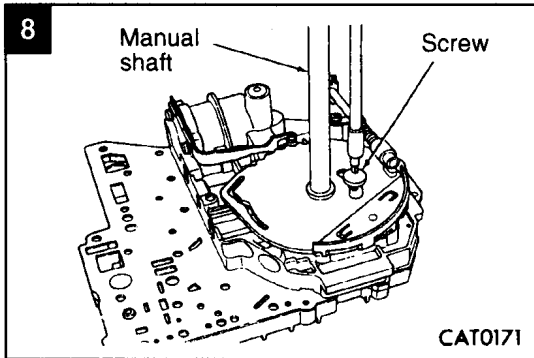

13 SPRINGS AND VALVES IDENTIFICATION

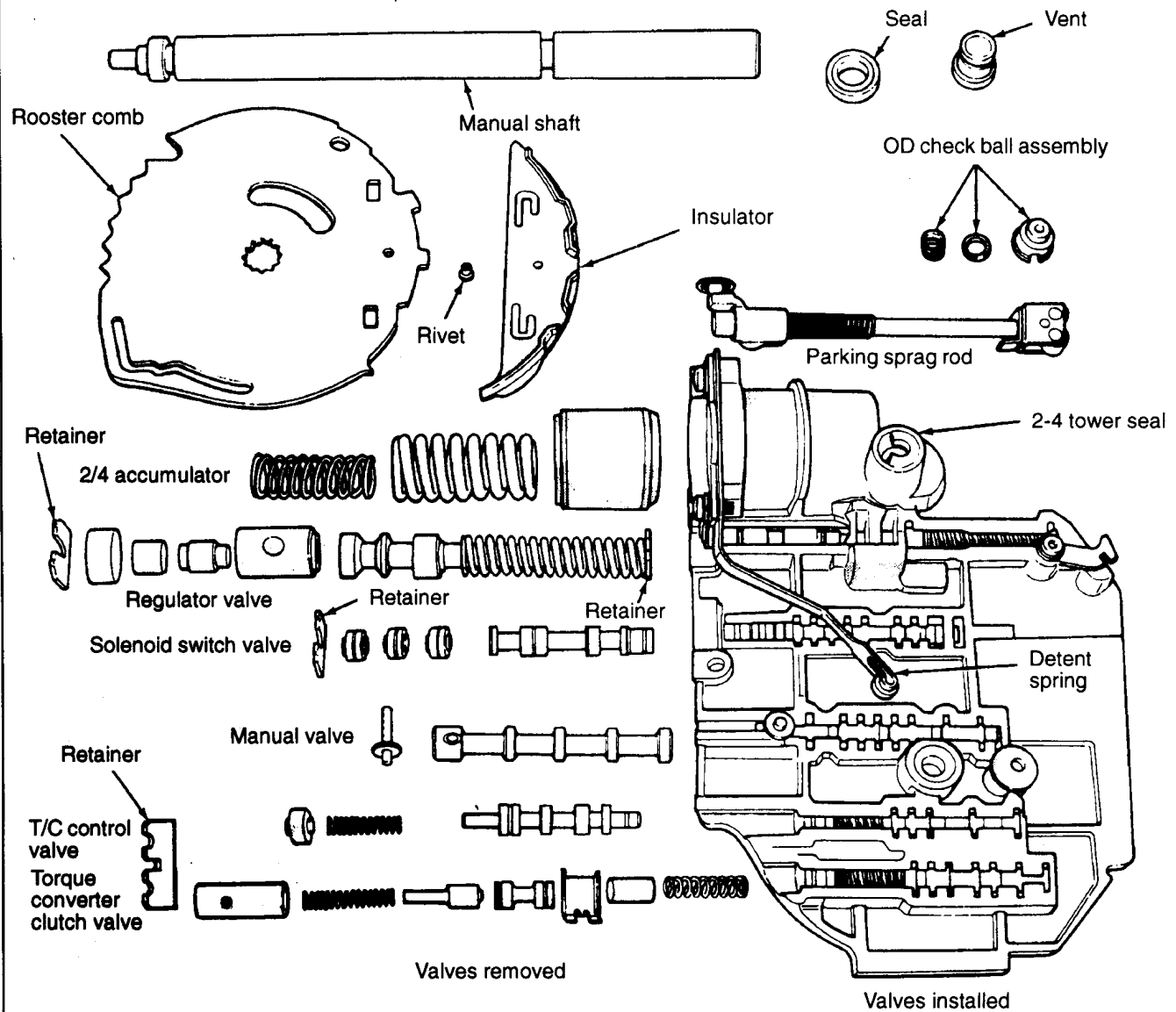

CAT0176

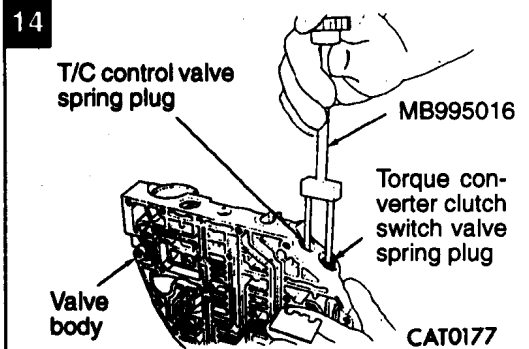

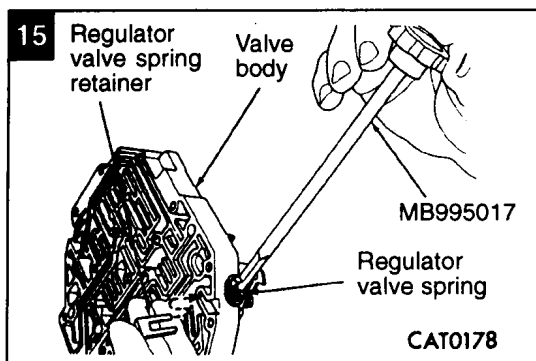

When installing valve body assembly onto transmission, observe step 5. Guide park rod rollers into guide bracket, while shifting manual lever assembly out of the installation position.

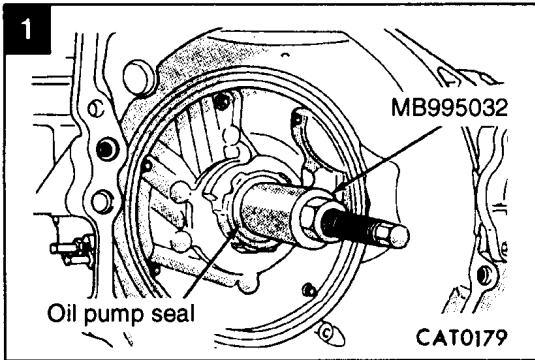

6. OIL PUMP SEAL REPLACE

Replace according to illustration numbers.

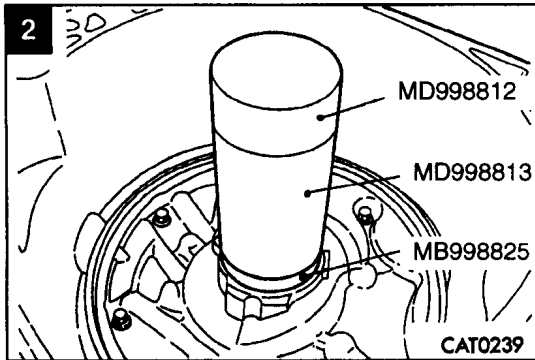

7. DIFFERENTIAL REPAIR

Repair according to illustration numbers.
The transfer shaft should be removed for differential repair and bearing turning torque checking.

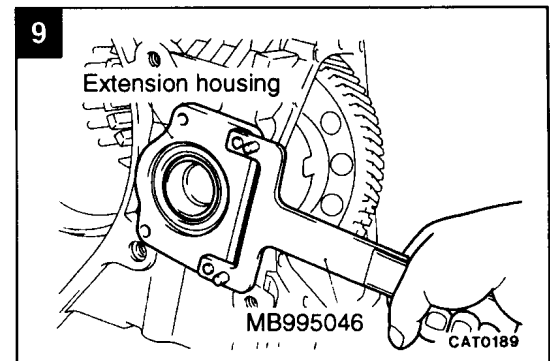
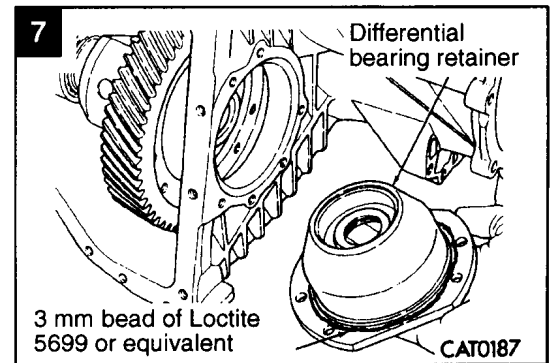
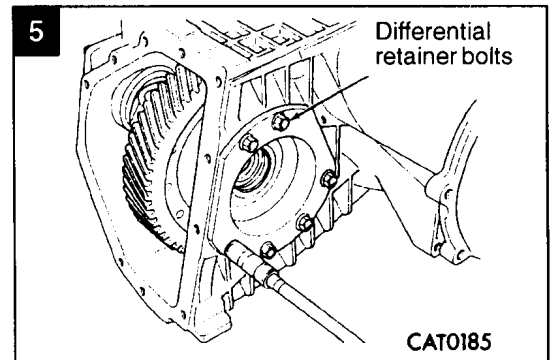
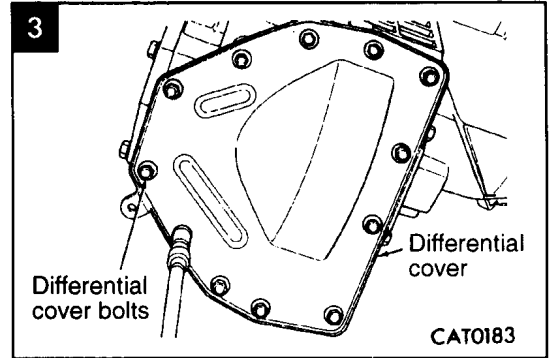
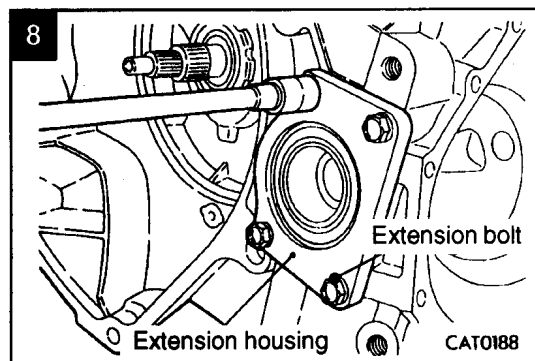
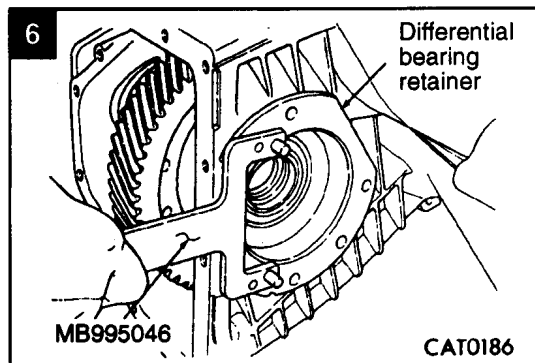
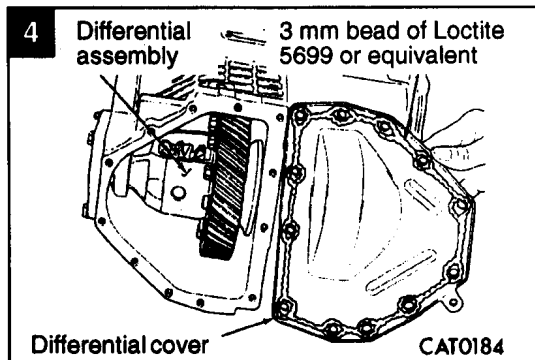
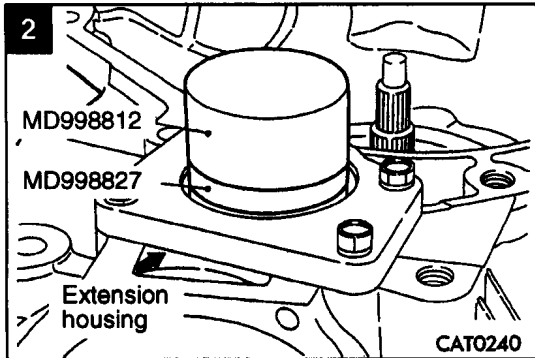
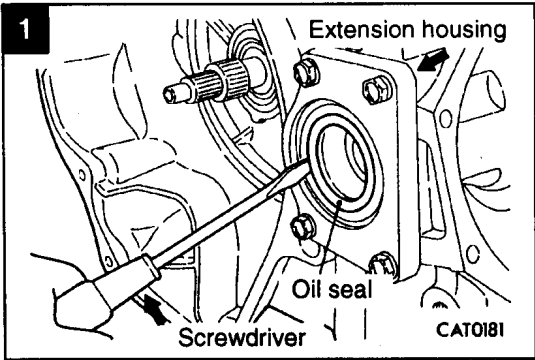

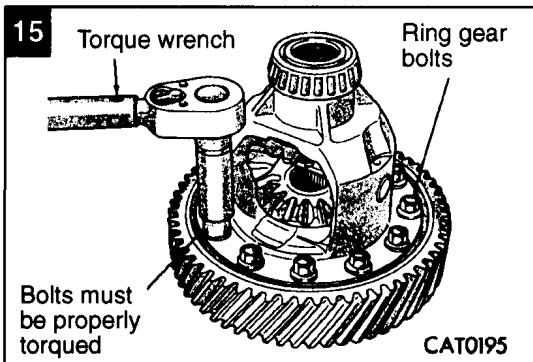
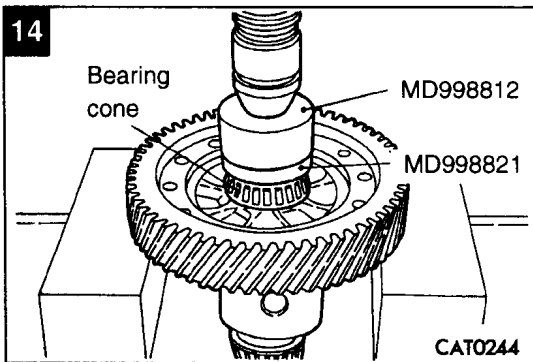
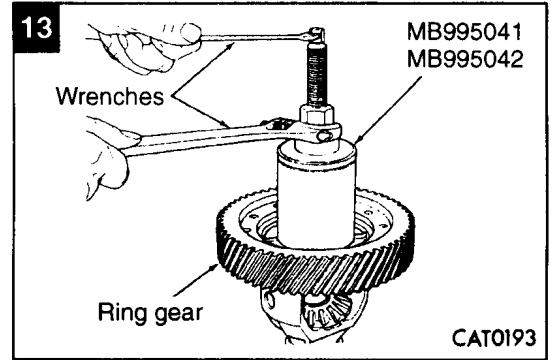
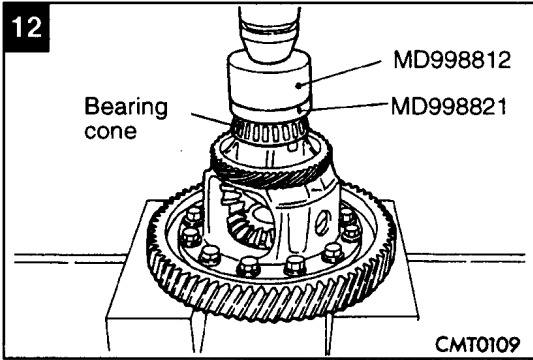
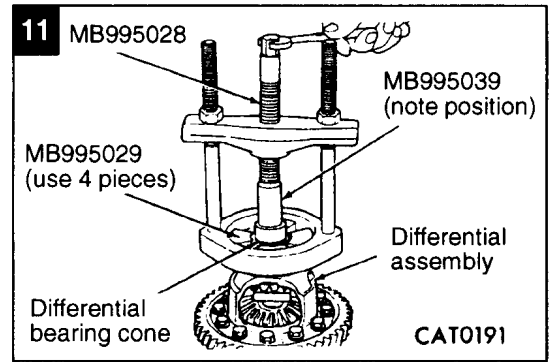
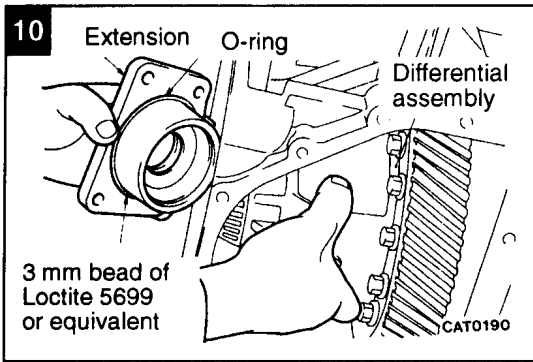

Caution

- Always install NEW ring gear bolts. Bolts must be properly torqued.

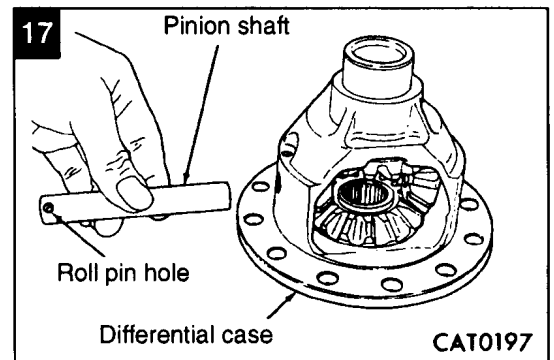
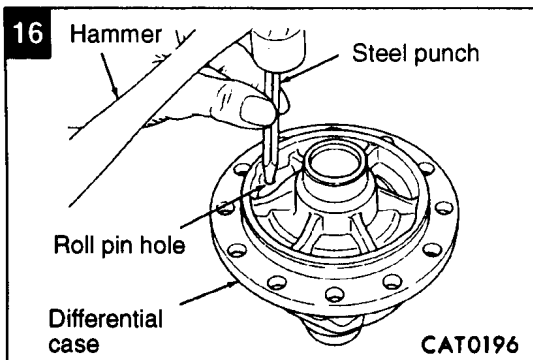

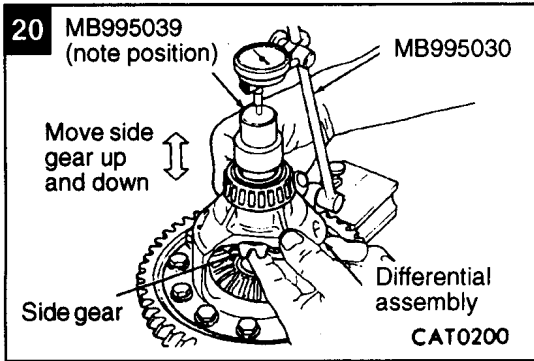
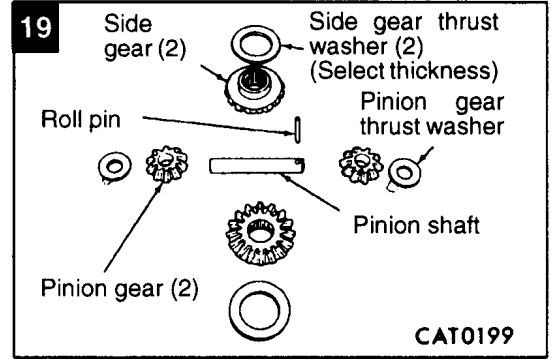
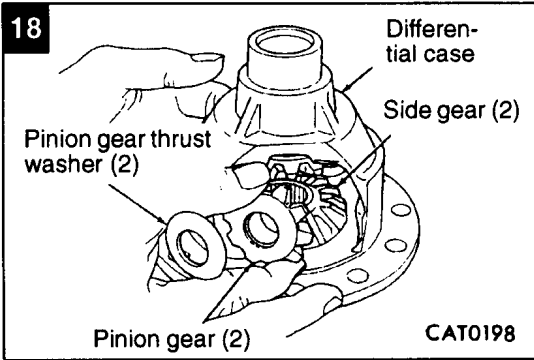

Caution

- Side gear end play must be within 0.025 to 0.330 mm.

Four select thrust washers are available 0.81, 0.93, 1.07 and 1.19 mm.

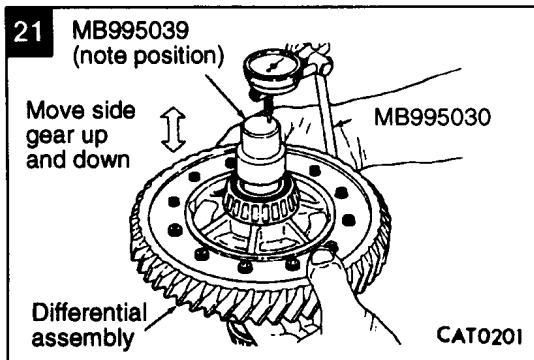

Caution

- Side gear end play must be within 0.025 to 0.330 mm.

Four select thrust washers are available: 0.81, 0.93, 1.07 and 1.19 mm.

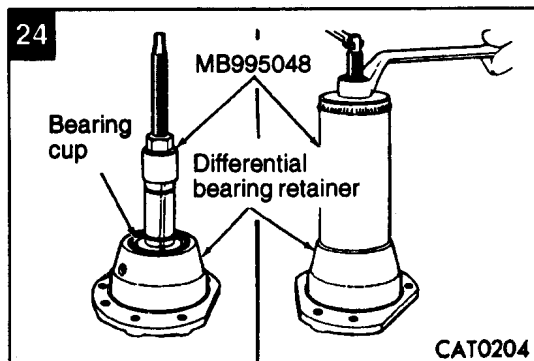
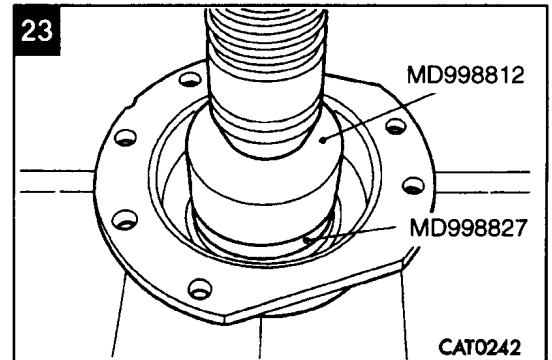
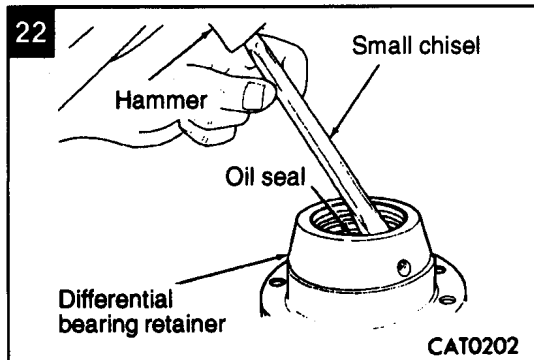

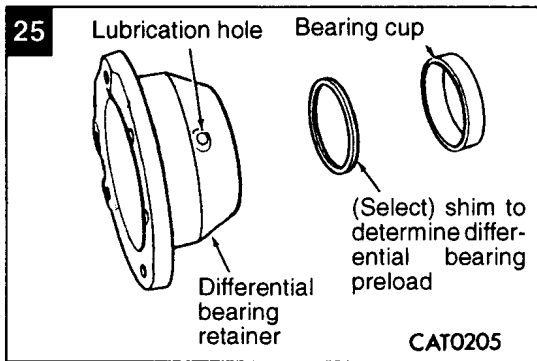

DETERMINING SHIM THICKNESS

Shim thickness need only be determined if any of the following parts are replaced:
 Transmission case
 Differential carrier
 Differential bearing retainer
 Extension housing
 Differential bearing cups and cones

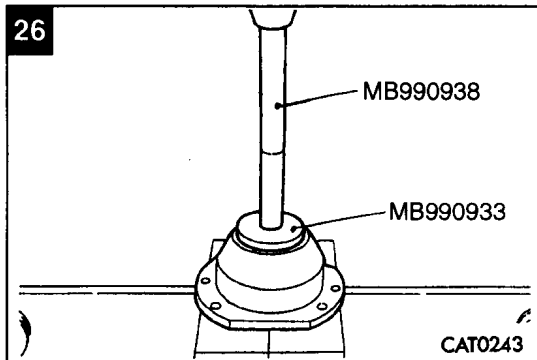

Refer to Bearing Adjustment Procedure in rear of this section to determine proper shim thickness. This will provide correct bearing preload and proper bearing turning torque.

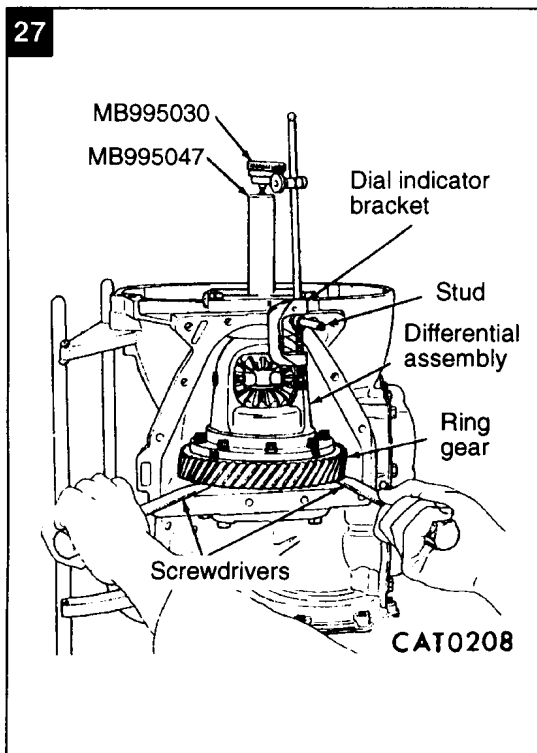

When rebuilding, reverse the above procedure. Remove oil sealant before applying new sealant. Use Loctite 5699 or equivalent on retainer to seal retainer to case.

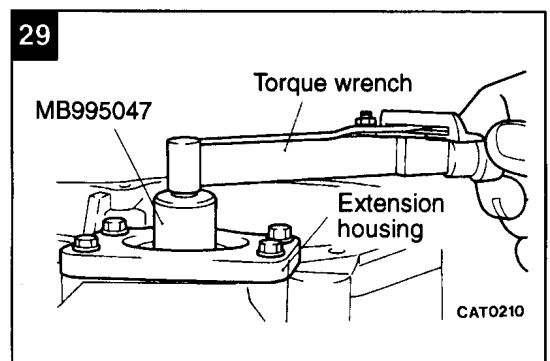
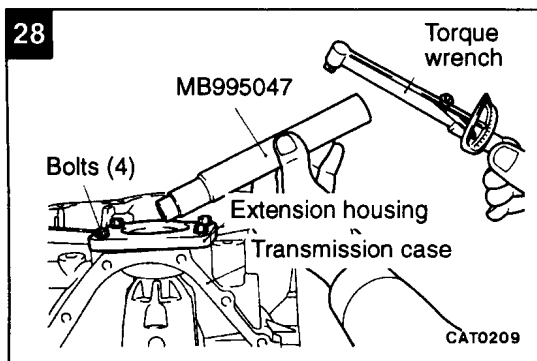

8. BEARING ADJUSTMENT PROCEDURE

GENERAL RULES ON SERVICING BEARING

- (1) Take extreme care when removing and installing bearing cups and cones. Use only an arbor press for installation, as a hammer may not properly align the bearing cup or cone. Burrs or nicks on the bearing seat will give a false end play reading, while gauging for proper shims. Improperly seated bearing cup and cones are subject to low-mileage failure.
- (2) Bearing cups and cones should be replaced if they show signs of pitting or heat distress.
Bearing end play and drag torque specifications must be maintained to avoid premature bearing failures.
Used (original) bearing may lose up to 50 of the original drag torque after break-in.
All bearing adjustments must be made with no other component interference or gear intermesh, except the transfer gear bearing.
Oil all bearings before checking turning torque.

OUTPUT GEAR BEARING

With output gear removed:

- (1) Install a 4.50 mm gauging shim on the rear carrier assembly hub, using grease to hold the shim in place.
- (2) Install output gear and bearing assembly. Torque to 271 Nm.
- (3) To measure bearing end play:
 - (a) Attach MB995045 to the gear.
 - (b) Push and pull the gear while rotating back and forth to insure seating of the bearing rollers.
 - (c) Using a dial indicator, mounted to the transmission case, measure output gear end play.
- (4) Once bearing end play has been determined, refer to the output gear bearing shim chart for the required shim.
- (5) Use MB995012 to remove the retaining bolt and washer. To remove the output gear, use MB995043, MB995044.
- (6) Remove the gauging shim and install the proper shim. Use grease to hold the shim in place. Install the output gear and bearing assembly.

Caution

- **Always use new retaining bolt, old retaining bolt may not be reused.**

- (7) Install the new retaining bolt and washer. Tighten to 271 Nm.
- (8) Using an inch-pound torque wrench, check the turning torque. The torque should be between 3 and 8 inch-pounds. If the turning torque is too high, install a 0.04 mm thicker shim. If the turning torque is too low, install a 0.04 mm thinner shim. Repeat until the proper turning torque is 3 to 8 inch pounds.

OUTPUT GEAR BEARING SHIM CHART

End Play (with 4.50 mm gauging shim installed)	Required Shim	End Play (with 4.50 mm gauging shim installed)	Required Shim
mm	mm	mm	mm
0.05	4.42	0.53	3.94
0.08	4.38	0.56	3.90
0.10	4.38	0.58	3.90
0.13	4.34	0.61	3.86
0.15	4.30	0.64	3.82
0.18	4.30	0.66	3.82
0.20	4.26	0.69	3.78
0.23	4.22	0.71	3.74
0.25	4.22	0.74	3.74
0.28	4.18	0.76	3.70
0.30	4.14	0.79	3.66
0.33	4.14	0.81	3.66
0.36	4.10	0.84	3.62
0.38	4.10	0.86	3.62
0.41	4.06	0.89	3.58
0.43	4.02	0.91	3.54
0.46	4.02	0.94	3.54
0.48	3.98	0.97	3.50
0.51	3.94		

DIFFERENTIAL BEARING

- (1) Remove the bearing cup from the differential bearing retainer using MB995048, and remove the existing shim from under the cup.
- (2) Install a 0.50 mm gauging shim and reinstall the bearing cup into the retainer. Use an arbor press to install the cup.
Oil baffle is not required when making shim selection.
- (3) Install the bearing retainer into the case and torque bolts to 28 Nm.
- (4) Position the transmission assembly vertically on the support stand and install MB995038 into side gear.
- (5) Rotate the differential at least one full revolution to ensure the tapered roller bearings are fully seated.
- (6) Attach a dial indicator to the case and zero the dial indicator. Place the indicator tip on the end of MB995047.
- (7) Place a large screwdriver to each side of the ring gear and lift. Check the dial indicator for the amount of end play.

Caution

- **Do not damage the transmission case and/or differential cover sealing surface.**
- (8) When the end play has been determined, refer to the Differential Bearing Shim Chart for correct shim combination.

DIFFERENTIAL BEARING SHIM CHART

End Play (with 0.50 mm gauging shim installed)	Required Shim Combination	Total Thickness
mm	mm	mm
0.0	0.50	0.50
0.05	0.75	0.75
0.10	0.80	0.80
0.15	0.85	0.85
0.20	0.90	0.90
0.25	0.95	0.95
0.30	1.00	1.00
0.35	1.05	1.05
0.40	0.50 + 0.60	1.10
0.45	0.50 + 0.65	1.15
0.50	0.50 + 0.70	1.20
0.55	0.50 + 0.75	1.25
0.60	0.50 + 0.80	1.30
0.65	0.50 + 0.85	1.35
0.70	0.50 + 0.90	1.40
0.75	0.50 + 0.95	1.45
0.80	0.50 + 1.00	1.50
0.85	0.50 + 1.05	1.55
0.90	1.00 + 0.60	1.60
0.95	1.00 + 0.65	1.65
1.00	1.00 + 0.70	1.70
1.05	1.00 + 0.75	1.75
1.10	1.00 + 0.80	1.80
1.15	1.00 + 0.85	1.85
1.20	1.00 + 0.90	1.90
1.25	1.00 + 0.95	1.95
1.30	1.00 + 1.00	2.00
1.35	1.00 + 1.05	2.05
1.40	1.05 + 1.05	2.10

- (9) Remove the differential bearing retainer. Remove the bearing cup and the 0.50 mm gauging shim.
 - (10) Install the proper shim combination under the bearing cup. Make sure the oil baffle is installed properly in the bearing retainer, below the bearing shim and cup.
 - (11) Install the differential bearing retainer. Seal the retainer to the housing with Loctite 5699 or equivalent and torque bolts to 28 Nm.
 - (12) Using MB995038 and an inch-pound torque wrench, check the turning torque of the differential. The turning torque should be between 0.56 and 2.03 Nm.
- If the turning torque is too high, install a 0.05 mm thinner shim. If the turning torque is too low, install a 0.05 mm thicker shim. Repeat until 0.56 and 2.03 Nm turning torque is obtained.

TRANSFER SHAFT BEARING

- (1) Use MB995012 to remove the retaining nut and washer. Remove the transfer shaft gear using MB995043, MB995044.
- (2) Install a 4.66 mm gauging shim on the transfer shaft.
- (3) Install transfer shaft gear and bearing assembly and torque the nut to 271 Nm.

23C-8-4 AUTOMATIC TRANSMISSION – Bearing Adjustment Procedure

- (4) To measure bearing end play:
 - (a) Attach MB995045 to the transfer gear.
 - (b) Mount a steel ball with grease into the end of the transfer shaft.
 - (c) Push and pull the gear while rotating back and forth to insure seating of the bearing rollers.
 - (d) Using a dial indicator, measure transfer shaft end play.
- (5) Refer to Transfer Bearing Shim Chart for the required shim combination to obtain the proper bearing setting.

TRANSFER BEARING SHIM CHART

End Play (with 4.66 mm gauging shim installed)	Required Shim	End Play (with 4.66 mm gauging shim installed)	Required Shim
mm	mm	mm	mm
0.05	4.66	0.79	3.90
0.08	4.62	0.81	3.90
0.10	4.58	0.84	3.86
0.13	4.58	0.86	3.82
0.15	4.54	0.89	3.82
0.18	4.50	0.91	3.78
0.20	4.50	0.94	3.74
0.23	4.46	0.97	3.74
0.25	4.46	0.99	3.70
0.28	4.42	1.02	3.66
0.30	4.38	1.04	3.66
0.33	4.38	1.07	3.62
0.36	4.34	1.08	3.62
0.38	4.30	1.12	3.58
0.41	4.30	1.14	3.54
0.43	4.26	1.17	3.54
0.46	4.22	1.19	3.50
0.48	4.22	1.22	3.46
0.50	4.18	1.24	3.46
0.53	4.18	1.27	3.42
0.56	4.14	1.30	3.38
0.58	4.10	1.32	3.38
0.61	4.10	1.35	3.34
0.64	4.06	1.37	3.34
0.66	4.02	1.40	3.30
0.69	4.02	1.42	3.26
0.71	3.98	1.45	3.26
0.74	3.94	1.47	3.22
0.76	3.94		

- (6) Use MB995012 to remove the retaining nut and washer. Remove the transfer shaft gear using MB995043, MB995044.
- (7) Remove the gauging shim and install the correct shim. Install the transfer gear and bearing assembly.

Caution

- **Original retaining nut may not be re-used. Always use a new retaining nut when reassembling.**

- (8) Install the new retaining nut and washer and torque to 271 Nm. Measure transfer shaft end play. The end play should be 0.05 to 0.10 mm.
- (9) Measure bearing end play as outlined in Step (4). End play should be between 0.05 to 0.10 mm.

If end play is too high, install a 0.04 mm thinner shim.
 If end play is too low, install a 0.04 mm thicker shim combination. Repeat until 0.05 to 0.10 mm end play is obtained.

BEARING SHIM CHART

Shim Thickness	Bearing Usage		
	mm	Output Gear	Transfer Shaft
3.22	×	×	–
3.26	×	×	–
3.30	×	×	–
3.34	×	×	–
3.38	×	×	–
3.42	×	×	–
3.46	×	×	–
3.50	×	×	–
3.54	×	×	–
3.58	×	×	–
3.62	×	×	–
3.66	×	×	–
3.70	×	×	–
3.74	×	×	–
3.78	×	×	–
3.82	×	×	–
3.86	×	×	–
3.90	×	×	–
3.94	×	×	–
3.98	×	×	–
4.02	×	×	–
4.06	×	×	–
4.10	×	×	–
4.14	×	×	–
4.18	×	×	–
4.22	×	×	–
4.26	×	×	–
4.30	×	×	–
4.34	×	×	–
4.38	×	×	–
4.42	×	×	–
4.46	×	×	–
4.50	×*	×	–
4.54	×	×	–
4.58	×	×	–
4.62	×	×	–
4.66	×	×*	–
0.50	–	–	×*
0.55	–	–	×
0.60	–	–	×
0.65	–	–	×
0.70	–	–	×
0.75	–	–	×
0.80	–	–	×
0.85	–	–	×
0.90	–	–	×
0.95	–	–	×
1.00	–	–	×
1.05	–	–	×

* Also used as gauging shims